

11340**MERCEDES BENZ E-550**

1/24/2021

GROSS LOAD CAPACITY WHEN USED AS A WEIGHT CARRYING HITCH: 2,000 LBS. TRAILER WEIGHT & 200 LBS. TONGUE WEIGHT.

*****DO NOT EXCEED VEHICLE MANUFACTURER'S RECOMMENDED TOWING CAPACITY.*****

WARNING: ALL NON-TRAILER LOADS APPLIED TO THIS PRODUCT MUST BE SUPPORTED BY 18050 STABILIZING STRAPS.

**** FAILURE TO PROPERLY SUPPORT NON-TRAILER LOADS WILL VOID PRODUCT WARRANTY****

HAVING INSTALLATION QUESTIONS? CALL TECHNICAL SUPPORT AT 1-877-287-8634

TOOLS REQUIRED

RATCHET
9" EXTENSION
3/4" SOCKET
10mm SOCKET
DRILL
17/32" DRILL BIT
CENTER PUNCH
TORQUE WRENCH

Parts List			
ITEM	QTY	PART NUMBER	DESCRIPTION
1	2	10-10278	BOLT,CAR,1/2-13 UNC,1-1/4,GRD8,YZ
2	2	10-10287	BOLT,CAR,1/2-13 UNC,1-1/2,GRD8,YZ
3	4	20-00062	NUT,SER-FLANGE,1/2-13 UNC,GRD8,YZ
4	2	CM-SP6	.250 x 1.00 x 3.00" SQUARE HOLE SPACER
5	2	1_2 FISHWIRE	1/2" FISHWIRE
6	4	10-10575	HHCS,1/2-13 UNC,3-1/4,CL10.9,YZ
7	4	30-00149	WASHER,S-CON,1/2,YZ
8	1	CM-NP1W	NUT PLATE WELDMENT

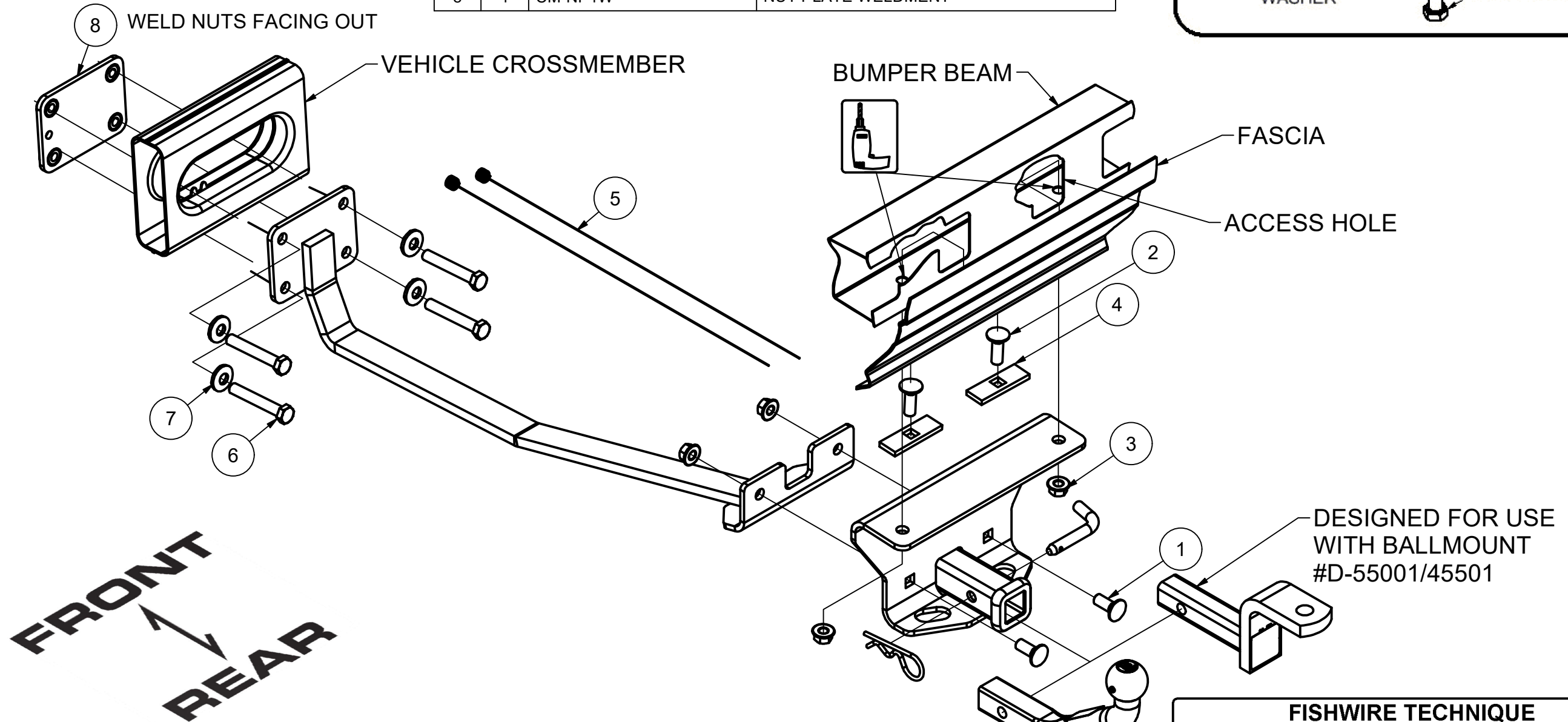
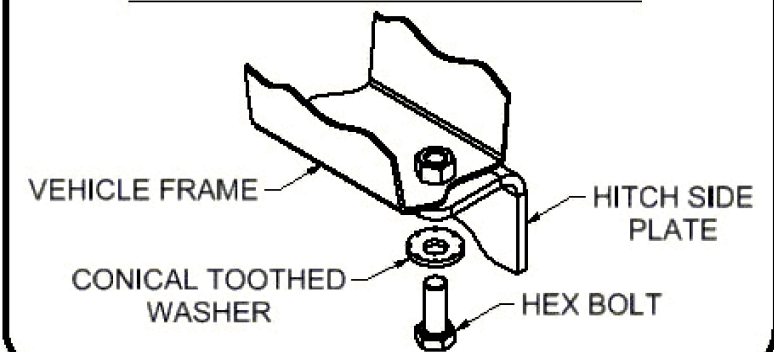
CONICAL TOOTHED WASHER ORIENTATION DIAGRAM

HITCH WEIGHT: 28 LBS.

INSTALL TIME

PROFESSIONAL: 30 MINUTES

NOVICE (DIY): 60 MINUTES

INSTALL NOTES:

- DRILLING REQUIRED
- FISHWIRE HARDWARE

EURO MOUNT OPTION AVAILABLE
#45571 (1 7/8" BALL) & #45572 (2" BALL)**FISHWIRE TECHNIQUE**

INSERT COILED END OF FISHWIRE TOOL THROUGH HITCH MOUNTING HOLE IN VEHICLE FRAME RAIL AND OUT THE ACCESS HOLE. PASS COILED END OF FISHWIRE THROUGH SPACER AND THREAD BOLT INTO COIL. KINK WIRE TO KEEP SPACER SEPERATE FROM BOLT AS SHOWN. PULL FISHWIRE, SPACER, AND BOLT THROUGH FRAME AND OUT MOUNTING HOLE. USE FISHWIRE TO GUIDE HITCH DURING MOUNTING AND PREVENT LOSS OF BOLT / SPACER INSIDE FRAME RAIL.

MOUNTING HOLE
ACCESS HOLE

NOTE: SOME VEHICLES MAY FISHWIRE THROUGH END OF FRAME

INSTALLATION STEPS

1. Remove fascia by removing two bolts using 10mm socket. Retain to reinstall after hitch is attached.
2. Raise nut plate (weld nuts facing the front of the vehicle) and mounting strap into position, around the vehicle crossmember. Secure using 1/2"-13 x 3 1/4" hex bolts and 1/2" conical toothed washers.
3. Raise hitch above fascia and secure to mounting strap using 1/2"-13 x 1 1/4" carriage bolts and 1/2"-13 flange nuts.
4. Press hitch against the bottom of the bumper beam, using the hitch as a template, mark hole locations with a center punch. **Note:** Verify hitch is centered on vehicle.
5. Lower hitch and drill marked hole locations with 17/32" drill bit.
6. Fishwire 1/2"-13 x 2" carriage bolts and SP6 spacers through the access holes between the fascia and the back of the bumper beam and into holes drilled in STEP 5. (See FISHWIRE TECHNIQUE DIAGRAM above)
7. Raise hitch back into position and secure with 1/2"-13 flange nuts.
8. Torque all 1/2" fasteners to 75 ft-lbs.
9. Reinstall fasteners removed in step 1.

PERIODICALLY CHECK THIS RECEIVER HITCH TO ENSURE THAT ALL FASTENERS ARE TIGHT AND THAT ALL STRUCTURAL COMPONENTS ARE SOUND.

Curt Manufacturing Inc., warrants this product to be free of defects in material and/or workmanship at the time of retail purchase by the original purchaser. If the product is found to be defective, Curt Manufacturing Inc., may repair or replace the product, at their option, when the product is returned, prepaid, with proof of purchase. Alteration to, misuse of, or improper installation of this product voids the warranty. Curt Manufacturing Inc.'s liability is limited to repair or replacement of products found to be defective, and specifically excludes liability for incidental or consequential loss or damage.



Safety glasses should be worn at all times while installing this product.

YEARS: 2011-CURRENT

MAKE: MERCEDES-BENZ

MODEL: E550

STYLE: 2 DOOR

WARNING: NEVER EXCEED YOUR VEHICLE MANUFACTURER'S RECOMMENDED TOWING CAPACITY

WEIGHT CARRYING:
 TRAILER WEIGHT: 2,000 LBS.
 TONGUE WEIGHT: 200 LBS.

WARNING:
 WE RECOMMEND THE USE OF 18050 STABILIZING STRAPS FOR ALL NON-TRAILER (WHEEL-LESS) LOADS. PLEASE SEE THE CURT CATALOG OR VISIT US ONLINE AT WWW.CURTMFG.COM FOR FURTHER INFORMATION.

INSTALLATION TIME: 30/60 MIN.

THE INSTALL TIME LISTED IS FOR PROFESSIONAL INSTALLERS. IF YOU ARE HESITANT TO UNDERTAKE THIS TASK ON YOUR OWN, CONTACT AN AUTHORIZED CURT INSTALLER FOR ADDITIONAL ASSISTANCE.

INSTALLATION REQUIRES:

RATCHET	TORQUE WRENCH	9" SOCKET EXTENSION
3/4" SOCKET	10mm SOCKET	CENTER PUNCH
POWER DRILL	DRILL BIT 17/32"	SAFETY GLASSES

INSTALLATION TIPS:

- BEFORE YOU BEGIN INSTALLATION, READ ALL INSTRUCTIONS THOROUGHLY.
- TO EASE INSTALLATION, 2 PEOPLE MAY BE REQUIRED.
- USING PROPER TOOLS WILL GREATLY IMPROVE THE QUALITY OF THE INSTALL AND REDUCE THE TIME REQUIRED.
- NEED HELP OR HAVE SOME QUESTIONS? CALL TECHNICAL SUPPORT AT 877.287.8634

LEVEL OF DIFFICULTY: MODERATE

EASY	MODERATE	CHALLENGING
DRILLING REQUIRED		
FISHWIRE HARDWARE		

VEHICLE PHOTO:



REPRESENTATIVE PHOTO

HITCH ILLUSTRATION:

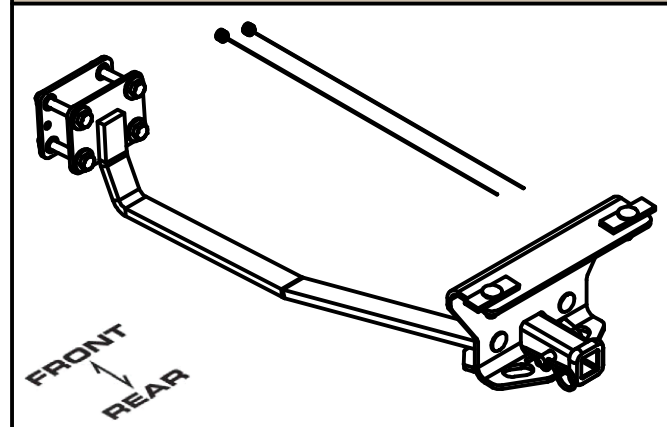

MAKE SURE YOUR HITCH MATCHES

PERIODICALLY CHECK THIS RECEIVER HITCH TO ENSURE ALL FASTENERS ARE TIGHT AND ALL STRUCTURAL COMPONENTS ARE SOUND

CURT Manufacturing LLC. warrants this product to be free of defects in material and/or workmanship at the time of retail purchase by the original purchaser. If the product is found to be defective, Curt Manufacturing LLC. may repair or replace the product at their option, when the product is returned, prepaid, with proof of purchase. Alteration to, misuse of, or improper installation of this product voids the warranty. Curt Manufacturing LLC.'s liability is limited to repair or replacement of products found to be defective, and specifically excludes liability for incidental or consequential loss or damage.

For more information log onto www.curtmfg.com, & for helpful towing tips log onto www.hitchinfo.com

INSTALLATION WALKTHROUGH:

Parts List			
ITEM	QTY	PART NUMBER	DESCRIPTION
1	2	10-10278	BOLT,CAR,1/2-13 UNC,1-1/4,GRD8,YZ
2	2	10-10287	BOLT,CAR,1/2-13 UNC,1-1/2,GRD8,YZ
3	4	20-00062	NUT,SER-FLANGE,1/2-13 UNC,GRD8,YZ
4	2	CM-SP6	.250 x 1.00 x 3.00" SQUARE HOLE SPACER
5	2	1_2 FISHWIRE	1/2" FISHWIRE
6	4	10-10575	HHCS,1/2-13 UNC,3-1/4,CL10.9,YZ
7	4	30-00149	WASHER,S-CON,1/2,YZ
8	1	CM-NP1W	NUT PLATE WELDMNT

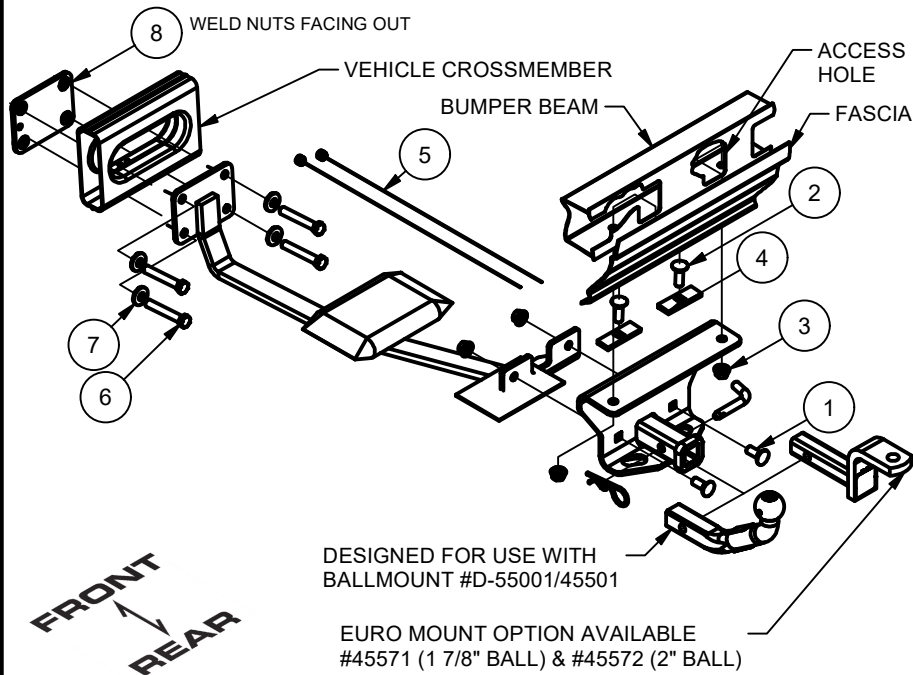

FISHWIRE TECHNIQUE

INSERT COILED END OF FISHWIRE TOOL THROUGH HITCH MOUNTING HOLE IN VEHICLE FRAME RAIL AND OUT THE ACCESS HOLE. PASS COILED END OF FISHWIRE THROUGH SPACER AND THREAD BOLT INTO COIL. KINK WIRE TO KEEP SPACER SEPARATE FROM BOLT AS SHOWN. PULL FISHWIRE, SPACER, AND BOLT THROUGH FRAME AND OUT MOUNTING HOLE. USE FISHWIRE TO GUIDE HITCH DURING MOUNTING AND PREVENT LOSS OF BOLT / SPACER INSIDE FRAME RAIL.

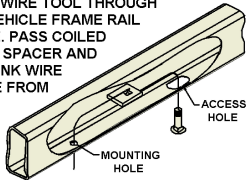

NOTE: SOME VEHICLES MAY FISHWIRE THROUGH END OF FRAME

CONICAL TOOTHED WASHER ORIENTATION DIAGRAM

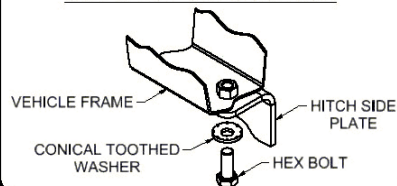

1. Remove fascia by removing two bolts using 10mm socket. Retain to reinstall after hitch is attached.

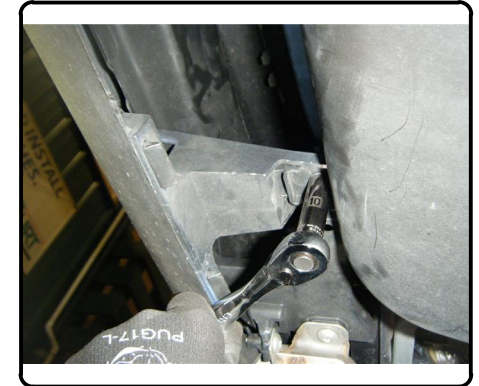

2. Raise nut plate (weld nuts facing the front of the vehicle) and mounting strap into position, around the vehicle crossmember. Secure using 1/2"-13 x 3 1/4" hex bolts and 1/2" conical toothed washers.

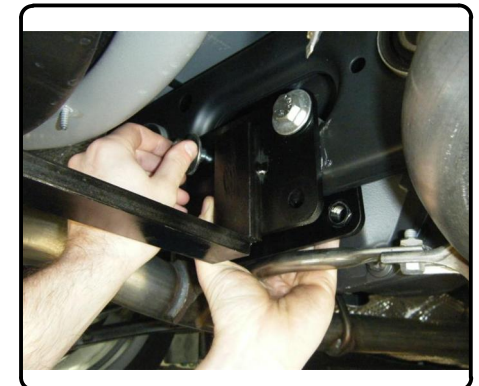
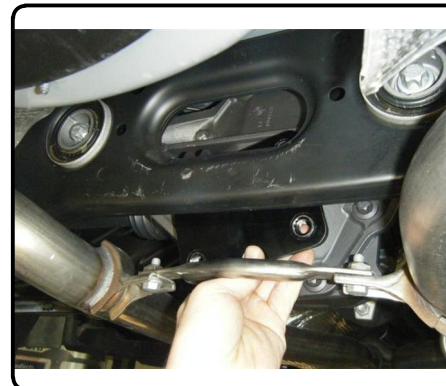

INSTALLATION WALKTHROUGH:

3. Raise hitch above fascia and secure to mounting strap using 1/2"-13 x 1 1/4" carriage bolts and 1/2"-13 flange nuts.

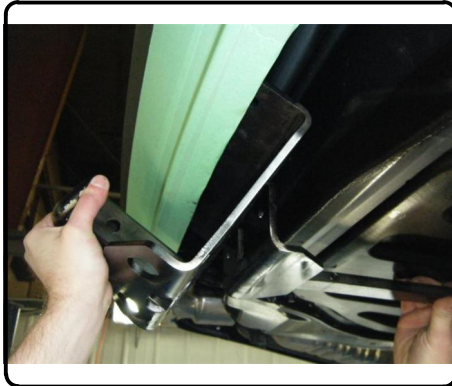

4. Press hitch against the bottom of the bumper beam, using the hitch as a template, mark hole locations with a center punch. **Note:** Verify hitch is centered on vehicle.

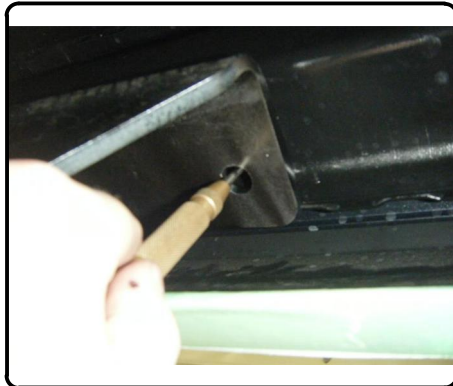

5. Lower hitch and drill marked hole locations with 17/32" drill bit.

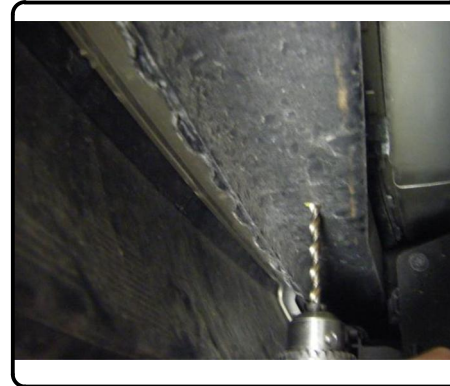

6. Fishwire 1/2"-13 x 2" carriage bolts and SP6 spacers through the access holes between the fascia and the back of the bumper beam and into holes drilled in STEP 5. (See FISHWIRE TECHNIQUE DIAGRAM on page 2)



INSTALLATION WALKTHROUGH:

7. Raise hitch back into position and secure with 1/2"-13 flange nuts.

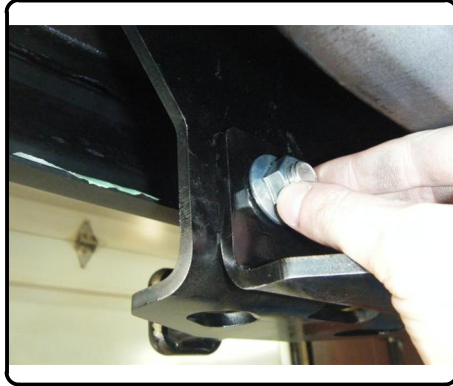

8. Torque all 1/2" fasteners to 75 ft-lbs.



9. Reinstall fasteners removed in step 1.



10. Install is now complete.

