

**11283****93-96 TOYOTA COROLLA WAGON**

11/30/2012

GROSS LOAD CAPACITY WHEN USED AS A WEIGHT CARRYING HITCH: 2,000 LBS. TRAILER WEIGHT &amp; 200 LBS. TONGUE WEIGHT.

**\*\*\*DO NOT EXCEED VEHICLE MANUFACTURER'S RECOMMENDED TOWING CAPACITY.\*\*\***

WARNING: ALL NON-TRAILER LOADS APPLIED TO THIS PRODUCT MUST BE SUPPORTED BY 18050 STABILIZING STRAPS.

**\*\* FAILURE TO PROPERLY SUPPORT NON-TRAILER LOADS WILL VOID PRODUCT WARRANTY\*\***

HAVING INSTALLATION QUESTIONS? CALL TECHNICAL SUPPORT AT 1-877-287-8634

Parts List			
ITEM	QTY	PART NUMBER	DESCRIPTION
1	6	M12 - 1.25 x 25 HEX	HEX BOLT
2	6	7/16 WASHER	WASHER
3	6	1/2"	LOCK WASHER

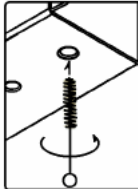
**WELDNUT CLEANING**

To remove debris from weldnuts in frame, spray lubricant or compressed air into hole. For heavy debris, use a small wire brush. (Be careful not to damage threads).

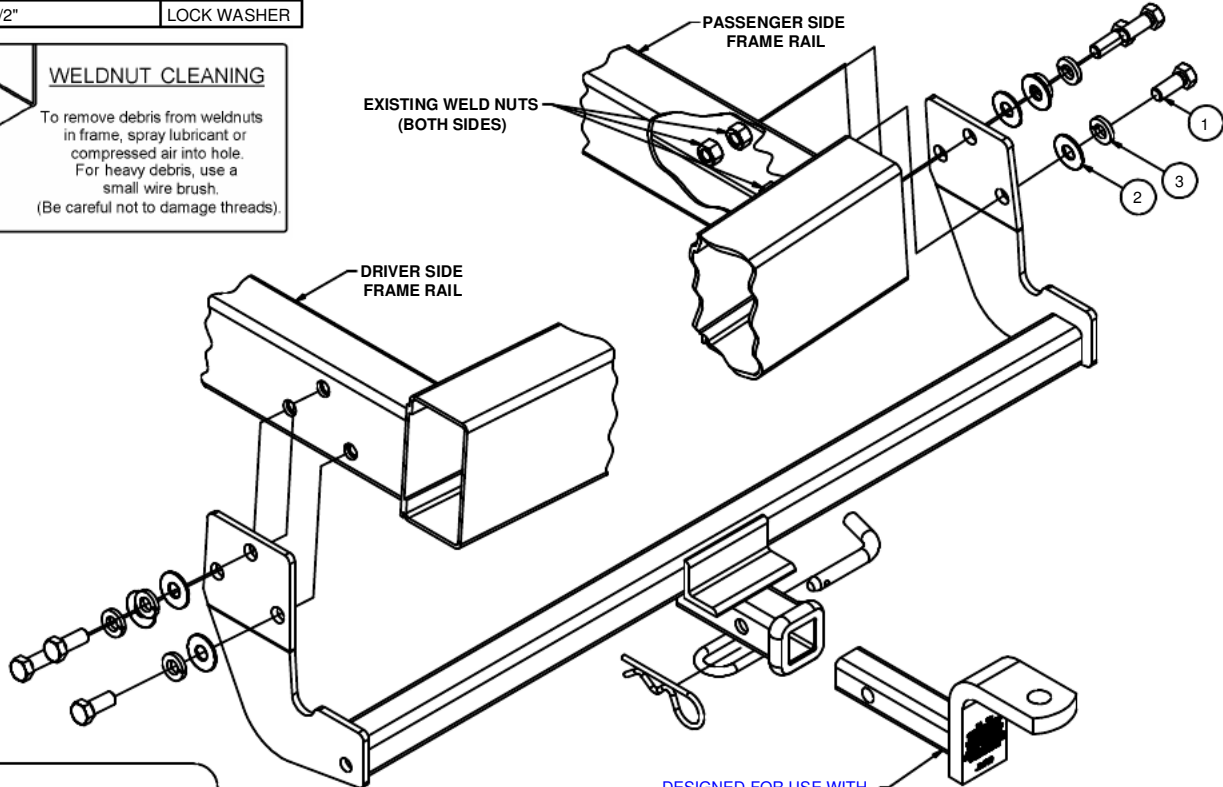

HITCH WEIGHT: 20 LBS.

**INSTALL TIME**

PROFESSIONAL: 20 MINUTES

NOVICE (DIY): 40 MINUTES

**INSTALL NOTES:**

- NO DRILLING REQUIRED
- REMOVE TIE DOWN BRACKETS

**INSTALLATION STEPS**

1. Under the rear of the vehicle, locate the box shape frame rails running front to back on the driver and passenger sides. (3) existing 12mm weldnuts are on the outer vertical wall of the frame rails. Tie down brackets may or may not be mounted at these weldnuts. If brackets are in place, remove them and return them to the vehicle's owner for reinstallation should the hitch ever be removed. This hitch will mount at these weldnuts using the fasteners provided with the hitch.
2. Position the hitch on the vehicle as shown in diagram by lining up the holes in the hitch side plates with the 12mm weldnuts in the vehicle's frame.
3. Fasten the hitch to the vehicle using fasteners as shown with flat and lock washers placed under the heads of the bolts. Hitch cross tube should pass below the rear bumper fascia.
4. Torque all 12mm fasteners to 86 lb-ft.

**PERIODICALLY CHECK THIS RECEIVER HITCH TO ENSURE THAT ALL FASTENERS ARE TIGHT AND THAT ALL STRUCTURAL COMPONENTS ARE SOUND.**

Curt Manufacturing Inc., warrants this product to be free of defects in material and/or workmanship at the time of retail purchase by the original purchaser. If the product is found to be defective, Curt Manufacturing Inc., may repair or replace the product, at their option, when the product is returned, prepaid, with proof of purchase. Alteration to, misuse of, or improper installation of this product voids the warranty. Curt Manufacturing Inc.'s liability is limited to repair or replacement of products found to be defective, and specifically excludes liability for incidental or consequential loss or damage.