

11263

## 2000-2006 NISSAN SENTRA SEDAN

10/1/2020

GROSS LOAD CAPACITY WHEN USED AS A WEIGHT CARRYING HITCH: 2,500 LBS. TRAILER WEIGHT &amp; 250 LBS. TONGUE WEIGHT.

**\*\*\*DO NOT EXCEED VEHICLE MANUFACTURER'S RECOMMENDED TOWING CAPACITY.\*\*\***

WARNING: ALL NON-TRAILER LOADS APPLIED TO THIS PRODUCT MUST BE SUPPORTED BY AUXILIARY STABILIZING STRAPS.

**\*\* FAILURE TO PROPERLY SUPPORT NON-TRAILER LOADS WILL VOID PRODUCT WARRANTY\*\***

HAVING INSTALLATION QUESTIONS? CALL TECHNICAL SUPPORT AT 877-287-8634

Parts List			
ITEM	QTY	PART NUMBER	DESCRIPTION
1	4	10-10339	HHCS,3/8-16 UNC,1-1/4,GRD8,YZ
2	4	30-00205	WASHER,FDR,3/8,CZ
3	4	30-00130	WASHER,LOCK,3/8,YZ
4	4	20-00166	NUT,HEX,3/8-16 UNC,GRD8,YZ
5	4	10-10464	HHCS,M8x1.25,45,CL10.9,YZ
6	4	30-00195	WASHER,FLAT,5/16,YZ
7	4	30-00219	5/16" LOCK WASHER, YZ

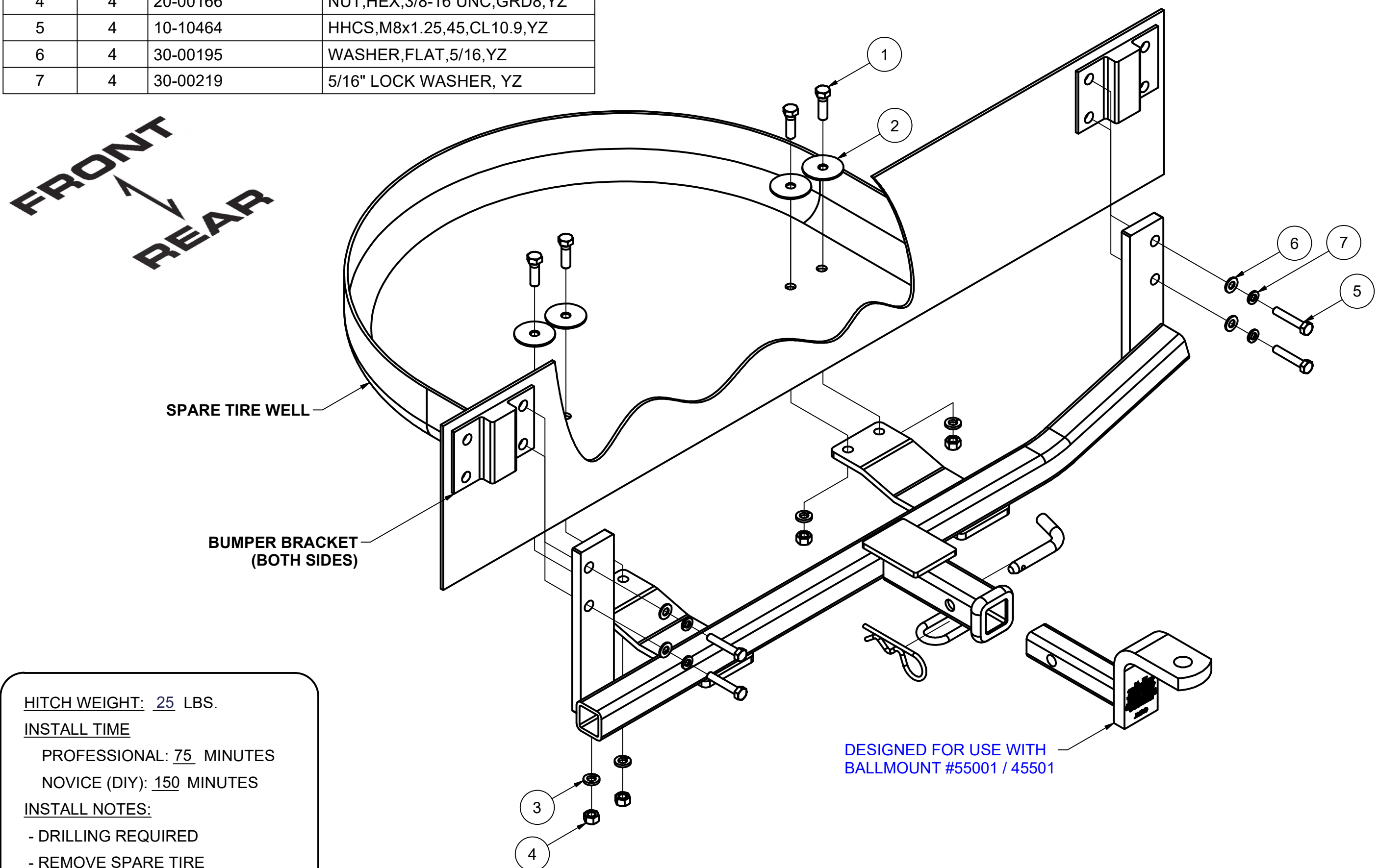

HITCH WEIGHT: 25 LBS.

INSTALL TIME

PROFESSIONAL: 75 MINUTES

NOVICE (DIY): 150 MINUTES

INSTALL NOTES:

- DRILLING REQUIRED
- REMOVE SPARE TIRE

**INSTALLATION STEPS**

1. This hitch fits to inboard bolts securing each bumper bracket (EA strut) to the chassis. This hitch also mounts to the tire well in four places using large fender washers inside.
2. Remove the spare tire and any articles from the tire well.
3. Remove two existing inboard bolts (8mm) from each bumper bracket/chassis flange and discard.
4. Position the hitch on the vehicle at chassis flanges and install fasteners as shown.
5. Using the hitch as a template, drill the tire well four places for 3/8" diameter screws. Fasten the hitch at the tire well as shown with the large fender washers inside; opposite the hitch.
6. Torque all 8mm hardware to 23 lb-ft, and all 3/8" hardware to 45 lb-ft.

**PERIODICALLY CHECK THIS RECEIVER HITCH TO ENSURE THAT ALL FASTENERS ARE TIGHT AND THAT ALL STRUCTURAL COMPONENTS ARE SOUND.**

Curt Manufacturing Inc., warrants this product to be free of defects in material and/or workmanship at the time of retail purchase by the original purchaser. If the product is found to be defective, Curt Manufacturing Inc., may repair or replace the product, at their option, when the product is returned, prepaid, with proof of purchase. Alteration to, misuse of, or improper installation of this product voids the warranty. Curt Manufacturing Inc.'s liability is limited to repair or replacement of products found to be defective, and specifically excludes liability for incidental or consequential loss or damage.