

**11250****HYUNDAI ACCENT & KIA RIO SEDAN**

12/7/2012

GROSS LOAD CAPACITY WHEN USED AS A WEIGHT CARRYING HITCH: 2,000 LBS. TRAILER WEIGHT &amp; 200 LBS. TONGUE WEIGHT.

**\*\*\*DO NOT EXCEED VEHICLE MANUFACTURER'S RECOMMENDED TOWING CAPACITY.\*\*\*****WARNING: ALL NON-TRAILER LOADS APPLIED TO THIS PRODUCT MUST BE SUPPORTED BY 18050 STABILIZING STRAPS.****\*\* FAILURE TO PROPERLY SUPPORT NON-TRAILER LOADS WILL VOID PRODUCT WARRANTY\*\***

HAVING INSTALLATION QUESTIONS? CALL TECHNICAL SUPPORT AT 1-800-798-0813

Parts List				
ITEM	QTY	PART NUMBER	DESCRIPTION	
1	2	7/16-14 x 1 1/4	CARRIAGE BOLT	
2	3	7/16-14	HEX FLANGE NUT	
3	3	CM-SP2	.250 x .88 x 2.25" SQUARE HOLE SPACER	
4	1	CM-SP34	.188 x 1.50 x 3.00" ROUND HOLE SPACER	
5	1	3/8-16 X 1 1/2	HEX BOLT	
6	1	3/8"	WASHER	
7	1	HFN3816	HEX FLANGE NUT	
8	2	7_16 FISHWIRE	7/16" FISHWIRE	
9	1	7/16-14 x 1 1/2	CARRIAGE BOLT	

TOOLS REQUIRED
RATCHET
TORQUE WRENCH
11/16" SOCKET
9/16" SOCKET
DRILL
15/32" DRILL BIT

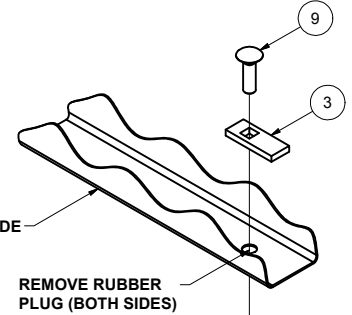
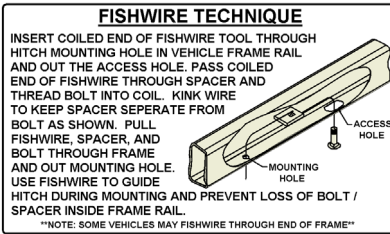
PASSENGER SIDE  
FRAME RAILREMOVE RUBBER  
PLUG (BOTH SIDES)**FISHWIRE TECHNIQUE**

INSERT COILED END OF FISHWIRE TOOL THROUGH HITCH MOUNTING HOLE IN VEHICLE FRAME RAIL AND OUT THE ACCESS HOLE. PASS COILED END OF FISHWIRE THROUGH SPACER AND THREAD BOLT INTO COIL. KINK WIRE TO KEEP SPACER SEPARATE FROM BOLT AS SHOWN. PULL FISHWIRE, SPACER, AND BOLT THROUGH FRAME AND OUT MOUNTING HOLE. USE FISHWIRE TO GUIDE HITCH DURING MOUNTING AND PREVENT LOSS OF BOLT / SPACER INSIDE FRAME RAIL.

\*\*NOTE: SOME VEHICLES MAY FISHWIRE THROUGH END OF FRAME\*\*

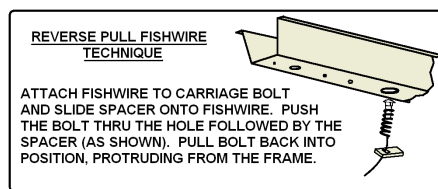
**REVERSE PULL FISHWIRE  
TECHNIQUE**

ATTACH FISHWIRE TO CARRIAGE BOLT AND SLIDE SPACER ONTO FISHWIRE. PUSH THE BOLT THRU THE HOLE FOLLOWED BY THE SPACER (AS SHOWN). PULL BOLT BACK INTO POSITION, PROTRUDING FROM THE FRAME.

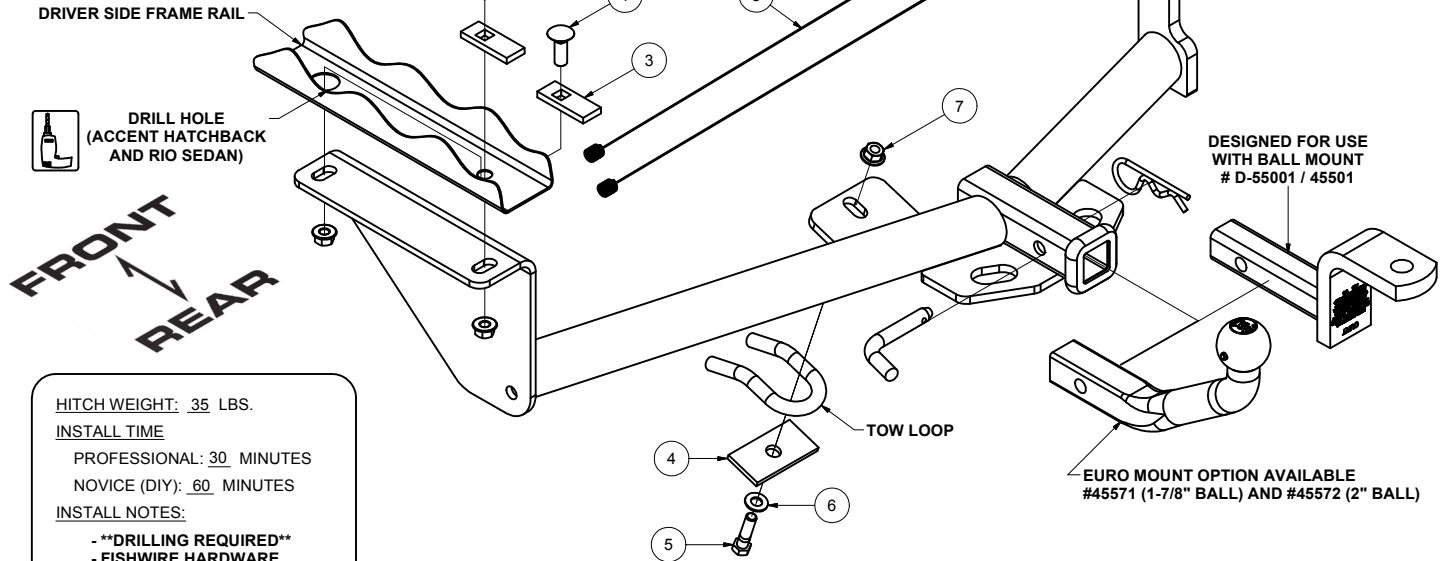

DRIVER SIDE FRAME RAIL

 DRILL HOLE  
(ACCENT HATCHBACK  
AND RIO SEDAN)

**FRONT**  
**REAR**
DESIGNED FOR USE  
WITH BALL MOUNT  
# D-55001 / 45501EURO MOUNT OPTION AVAILABLE  
#45571 (1-7/8" BALL) AND #45572 (2" BALL)

HITCH WEIGHT: 35 LBS.

**INSTALL TIME**

PROFESSIONAL: 30 MINUTES

NOVICE (DIY): 60 MINUTES

**INSTALL NOTES:**

- \*\*DRILLING REQUIRED\*\*
- FISHWIRE HARDWARE
- REMOVE RUBBER PLUGS

**\*\*Note: Hyundai Accent sedan does not require drilling.\*\*****INSTALLATION STEPS**

1. If present, remove rubber plugs from frame holes and return to owner.
2. Raise hitch into position with the tow loop mounting tab resting on top of the tow hook. If not present, mark the forward hole on the driver side frame rail and drill with a 15/32" drill bit. Remove hitch. **Note:** Hyundai Accent sedan does not require drilling.
3. Fishwire (1) 7/16" carriage bolt and (1) CM-SP2 spacer through the access hole into the forward hole on the driver side. Reverse Fishwire (1) 7/16" carriage bolt and (1) CM-SP2 spacer into the access hole on each side. Refer to "Reverse Pull Fishwire Technique & Fishwire Technique" as shown above. **Note:** The access hole location will vary in depending on vehicle model.
4. Raise the hitch back into position. Be careful not to push the carriage bolts back into the frame. Loosely install (3) 7/16" hex flange nuts.
5. Install the remaining 3/8" hardware with (1) CM-SP34 spacer onto the vehicle tow loop, as shown above.
6. Torque all 3/8" fasteners to 45 lb-ft and all 7/16" fasteners to 70 lb-ft.

**PERIODICALLY CHECK THIS RECEIVER HITCH TO ENSURE THAT ALL FASTENERS  
ARE TIGHT AND THAT ALL STRUCTURAL COMPONENTS ARE SOUND.**

Curt Manufacturing LLC., warrants this product to be free of defects in material and/or workmanship at the time of retail purchase by the original purchaser. If the product is found to be defective, Curt Manufacturing LLC., may repair or replace the product, at their option, when the product is returned, prepaid, with proof of purchase. Alteration to, misuse of, or improper installation of this product voids the warranty. Curt Manufacturing LLC.'s liability is limited to repair or replacement of products found to be defective, and specifically excludes liability for incidental or consequential loss or damage.



Safety glasses should be worn at all times while installing this product.

YEARS: 2012

MAKE: HYUNDAI & KIA

MODEL: ACCENT & RIO SEDAN

STYLE: COMPACT

**WARNING: NEVER EXCEED YOUR VEHICLE MANUFACTURER'S RECOMMENDED TOWING CAPACITY**

**WEIGHT CARRYING:**  
 TRAILER WEIGHT: 2,000 LBS.  
 TONGUE WEIGHT: 200 LBS.

**WARNING:**  
 WE RECOMMEND THE USE OF 18050 STABILIZING STRAPS FOR ALL NON-TRAILER (WHEEL-LESS) LOADS. PLEASE SEE THE CURT CATALOG OR VISIT US ONLINE AT [WWW.CURTMFG.COM](http://WWW.CURTMFG.COM) FOR FURTHER INFORMATION.

**INSTALLATION TIME: 30 MIN.**

THE INSTALL TIME LISTED IS FOR PROFESSIONAL INSTALLERS. IF YOU ARE HESITANT TO UNDERTAKE THIS TASK ON YOUR OWN, CONTACT AN AUTHORIZED CURT INSTALLER FOR ADDITIONAL ASSISTANCE.

**INSTALLATION REQUIRES:**

<b>RATCHET</b>	<b>TORQUE WRENCH</b>	<b>11/16\"/&gt; 9/16\" SOCKET</b>
<b>SAFETY GLASSES</b>	<b>DRILL BIT 15/32\"</b>	<b>POWER DRILL</b>

**INSTALLATION TIPS:**

- BEFORE YOU BEGIN INSTALLATION, READ ALL INSTRUCTIONS THOROUGHLY.
- TO EASE INSTALLATION, 2 PEOPLE MAY BE REQUIRED.
- USING PROPER TOOLS WILL GREATLY IMPROVE THE QUALITY OF THE INSTALL AND REDUCE THE TIME REQUIRED.
- NEED HELP OR HAVE SOME QUESTIONS? CALL TECHNICAL SUPPORT AT 800.798.0813

**LEVEL OF DIFFICULTY: EASY**

<i>EASY</i>	<i>MODERATE</i>	<i>CHALLENGING</i>
	Remove rubber plugs (If present)	
	"Reverse pull" fishwire (2) bolts and (2) spacers	
	Fishwire (2) bolts and (2) spacers	

**VEHICLE PHOTO:**



REPRESENTATIVE PHOTO

**HITCH ILLUSTRATION:**

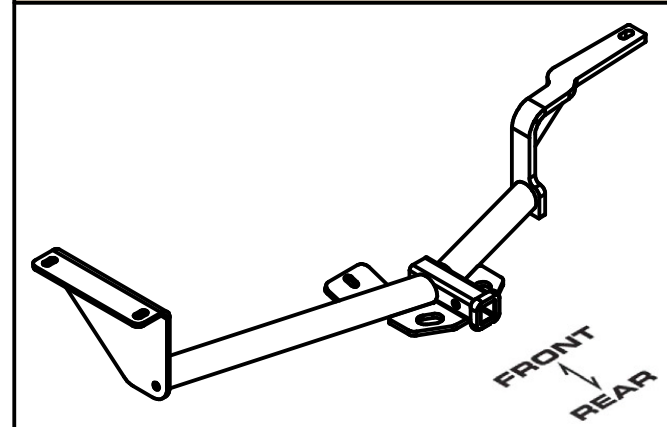

MAKE SURE YOUR HITCH MATCHES

**PERIODICALLY CHECK THIS RECEIVER HITCH TO ENSURE ALL FASTENERS ARE TIGHT AND ALL STRUCTURAL COMPONENTS ARE SOUND**

CURT Manufacturing LLC. warrants this product to be free of defects in material and/or workmanship at the time of retail purchase by the original purchaser. If the product is found to be defective, Curt Manufacturing LLC. may repair or replace the product at their option, when the product is returned, prepaid, with proof of purchase. Alteration to, misuse of, or improper installation of this product voids the warranty. Curt Manufacturing LLC.'s liability is limited to repair or replacement of products found to be defective, and specifically excludes liability for incidental or consequential loss or damage.

For more information log onto [www.curtmfg.com](http://www.curtmfg.com), & for helpful towing tips log onto [www.hitchinfo.com](http://www.hitchinfo.com)

# INSTALLATION WALKTHROUGH:

Parts List			
ITEM	QTY	PART NUMBER	DESCRIPTION
1	2	7/16-14 x 1 1/4	CARRIAGE BOLT
2	3	7/16-14	HEX FLANGE NUT
3	3	CM-SP2	.250 x .88 x 2.25" SQUARE HOLE SPACER
4	1	CM-SP34	.188 x 1.50 x 3.00" ROUND HOLE SPACER
5	1	3/8-16 X 1 1/2	HEX BOLT
6	1	3/8"	WASHER
7	1	HFN3816	HEX FLANGE NUT
8	2	7_16 FISHWIRE	7/16" FISHWIRE
9	1	7/16-14 x 1 1/2	CARRIAGE BOLT

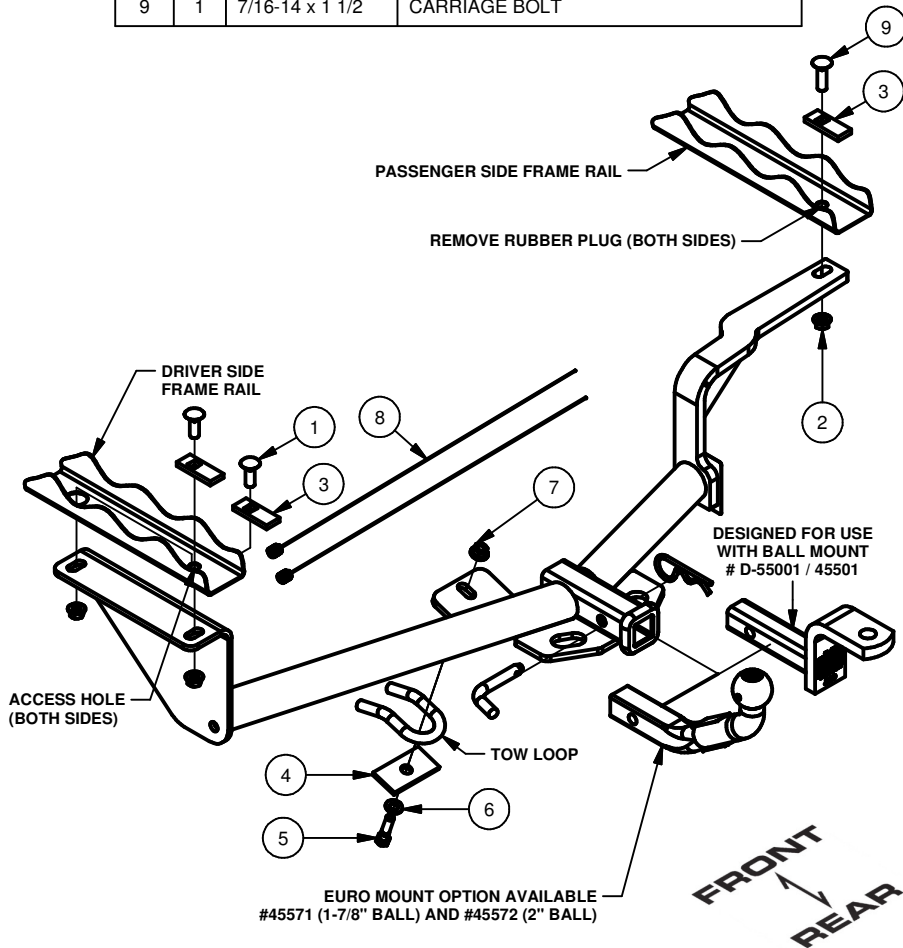

1. If present, Remove rubber plugs from frame holes and return to owner.



2. Raise hitch into position with the tow loop mounting tab resting on top of the tow hook. Mark the forward hole on the driver side frame rail and drill with a 15/32" drill bit. Remove hitch. **Note:** Hyundai Accent sedan does not require drilling.





## INSTALLATION WALKTHROUGH:

3. Fishwire (1) 7/16" carriage bolt and (1) CM-SP2 spacer through the access hole into the forward hole on the driver side. Reverse Fishwire (1) 7/16" carriage bolt and (1) CM-SP2 spacer into the access hole on each side.

**Note:** The access hole location will vary depending on the vehicle model.

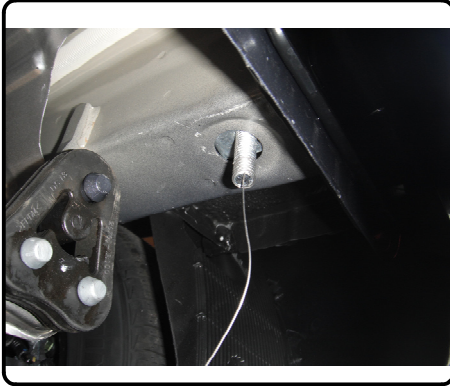

4. Raise the hitch back into position. Be careful not to push the carriage bolts back into the frame. Loosely install (3) 7/16" hex flange nuts.



5. Install the remaining 3/8" hardware with (1) CM-SP34 spacer onto the vehicle tow loop, as shown above.



6. Torque all 3/8" fasteners to 45 lb-ft and all 7/16" fasteners to 70 lb-ft.

