

11241

93-02 MAZDA 626 / MX-6 & 93-97 MX-6

10/09/2020

GROSS LOAD CAPACITY WHEN USED AS A WEIGHT CARRYING HITCH: 2,000 LBS. TRAILER WEIGHT & 200 LBS. TONGUE WEIGHT.

*****DO NOT EXCEED VEHICLE MANUFACTURER'S RECOMMENDED TOWING CAPACITY.*****

WARNING: ALL NON-TRAILER LOADS APPLIED TO THIS PRODUCT MUST BE SUPPORTED BY AUXILIARY STABILIZING STRAPS.

**** FAILURE TO PROPERLY SUPPORT NON-TRAILER LOADS WILL VOID PRODUCT WARRANTY****

HAVING INSTALLATION QUESTIONS? CALL TECHNICAL SUPPORT AT 877-287-8634

Parts List				
ITEM	QTY	PART NUMBER	DESCRIPTION	
1	6	10-10282	BOLT,CAR,7/16-14 UNC,1-1/2,GRD8,YZ	
2	6	30-00184	WASHER,LOCK,7/16,YZ	
3	6	20-00147	NUT,HEX,7/16-14 UNC,GRD8,YZ	
4	6	CM-SP2	.250 x .88 x 2.25" SQUARE HOLE SPACER	
5	1	7_16 FISHWIRE	7/16" FISHWIRE	

**RUBBER ISOLATOR
REMOVAL DIAGRAM**

This technique can be used if and Exhaust Hanger Removal Pliers is not available.

Using a 5/8" open end wrench, slide the wrench up to the rubber isolator, cradling the hanger rod as shown. Next place the flat edge of a pry bar between the wrench and the hanger stop or hanger rod. Then simply rotate the pry bar toward the wrench to remove the rubber isolator.

Note: Using a spray lubricant or soapy water on the hanger rod and the rubber isolator helps removal.

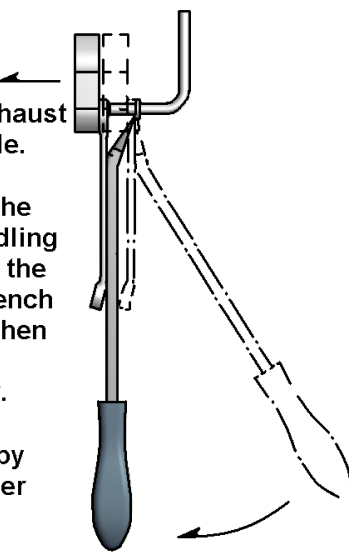
**FISHWIRE TECHNIQUE**

INSERT COILED END OF FISHWIRE TOOL THROUGH HITCH MOUNTING HOLE IN VEHICLE FRAME RAIL AND OUT THE ACCESS HOLE. PASS COILED END OF FISHWIRE THROUGH SPACER AND THREAD BOLT INTO COIL. KINK WIRE TO KEEP SPACER SEPERATE FROM BOLT AS SHOWN. PULL FISHWIRE, SPACER, AND BOLT THROUGH FRAME AND OUT MOUNTING HOLE. USE FISHWIRE TO GUIDE HITCH DURING MOUNTING AND PREVENT LOSS OF BOLT / SPACER INSIDE FRAME RAIL.

NOTE: SOME VEHICLES MAY FISHWIRE THROUGH END OF FRAME

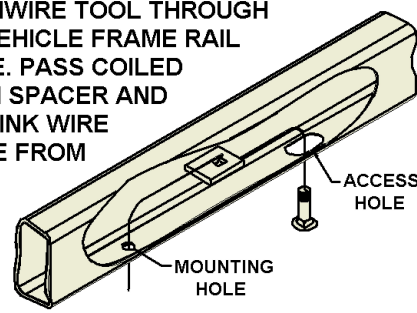

HITCH WEIGHT: 27 LBS.

INSTALL TIME

PROFESSIONAL: 45 MINUTES

NOVICE (DIY): 90 MINUTES

INSTALL NOTES:

-DRILLING REQUIRED

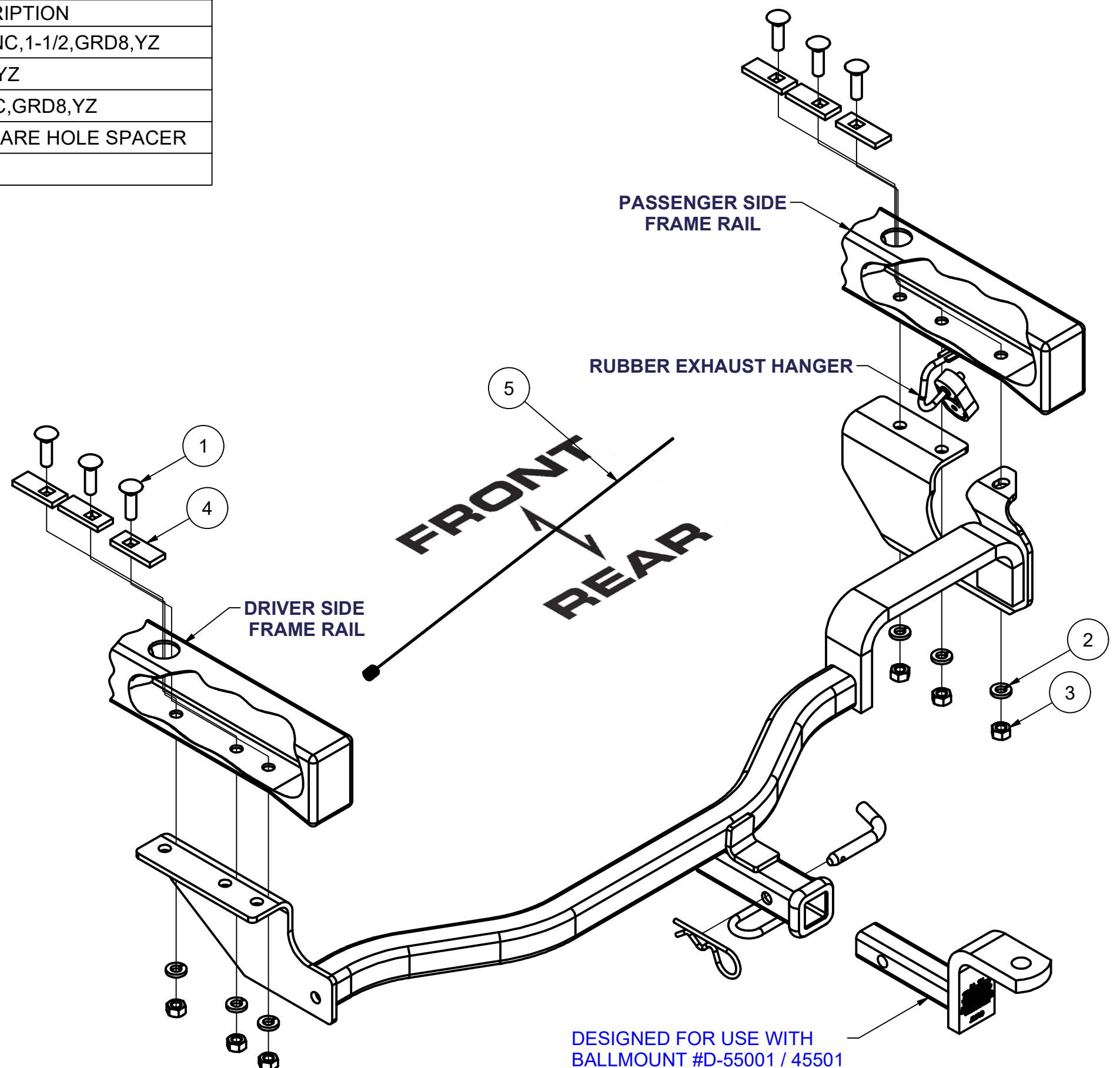
**INSTALLATION STEPS**

1. Temporarily lower the car's exhaust at the rear bumper by removing one end of each rubber exhaust hanger near the muffler.
2. Place the hitch into position under the car by passing the hitch over the exhaust tips. The hitch end brackets will mount to the bottom of the frame rails on each side. Locate the hitch by lining up the bracket holes with existing holes in frame rails. Using the hitch as a template, drill the remaining holes in the bottom surface of the rails with a 1/2" diameter drill bit.
3. The carriage bolts and backing plates are placed inside the frame rails by making one access hole in the top of each frame rail from inside the car's trunk area. Notice a plastic hole plug in each side of the trunk floor. Mark the small holes in the top of each frame rail. Enlarge these holes to 1 1/4" diameter using a hole saw. Carriage bolts and backing plates are then fishwired into place, three per side.
4. Fasten with lock washers and nuts as shown.
5. Torque all 7/16" fasteners to 70 lb-ft.

PERIODICALLY CHECK THIS RECEIVER HITCH TO ENSURE THAT ALL FASTENERS ARE TIGHT AND THAT ALL STRUCTURAL COMPONENTS ARE SOUND.

Curt Manufacturing Inc., warrants this product to be free of defects in material and/or workmanship at the time of retail purchase by the original purchaser. If the product is found to be defective, Curt Manufacturing Inc., may repair or replace the product, at their option, when the product is returned, prepaid, with proof of purchase. Alteration to, misuse of, or improper installation of this product voids the warranty. Curt Manufacturing Inc.'s liability is limited to repair or replacement of products found to be defective, and specifically excludes liability for incidental or consequential loss or damage.

24665 / 247238