

11220

01-06 HYUNDAI ELANTRA SEDAN / HATCHBACK

9/14/2020

GROSS LOAD CAPACITY WHEN USED AS A WEIGHT CARRYING HITCH: 2,000 LBS. TRAILER WEIGHT & 200 LBS. TONGUE WEIGHT.

*****DO NOT EXCEED VEHICLE MANUFACTURER'S RECOMMENDED TOWING CAPACITY.*****

WARNING: ALL NON-TRAILER LOADS APPLIED TO THIS PRODUCT MUST BE SUPPORTED BY AUXILIARY STABILIZING STRAPS.

**** FAILURE TO PROPERLY SUPPORT NON-TRAILER LOADS WILL VOID PRODUCT WARRANTY****

HAVING INSTALLATION QUESTIONS? CALL TECHNICAL SUPPORT AT 877-287-8634

| Parts List | | | |
|------------|-----|-------------|--|
| ITEM | QTY | PART NUMBER | DESCRIPTION |
| 1 | 2 | 10-10398 | HHCS,M10x1.25,40,CL10.9,YZ |
| 2 | 2 | 30-00166 | WASHER,FLAT,7/16,YZ |
| 3 | 2 | 30-00184 | WASHER,LOCK,7/16,YZ |
| 4 | 1 | 30-00153 | WASHER,LOCK,1/2,YZ |
| 5 | 1 | 20-00171 | NUT,HEX,1/2-13 UNC,GRD8,YZ |
| 6 | 1 | 10-10272 | BOLT,CAR,1/2-13 UNC,1-3/4,GRD8,YZ |
| 7 | 1 | CM-SP4 | .250 x 1.50 x 3.00" SQUARE HOLE SPACER |

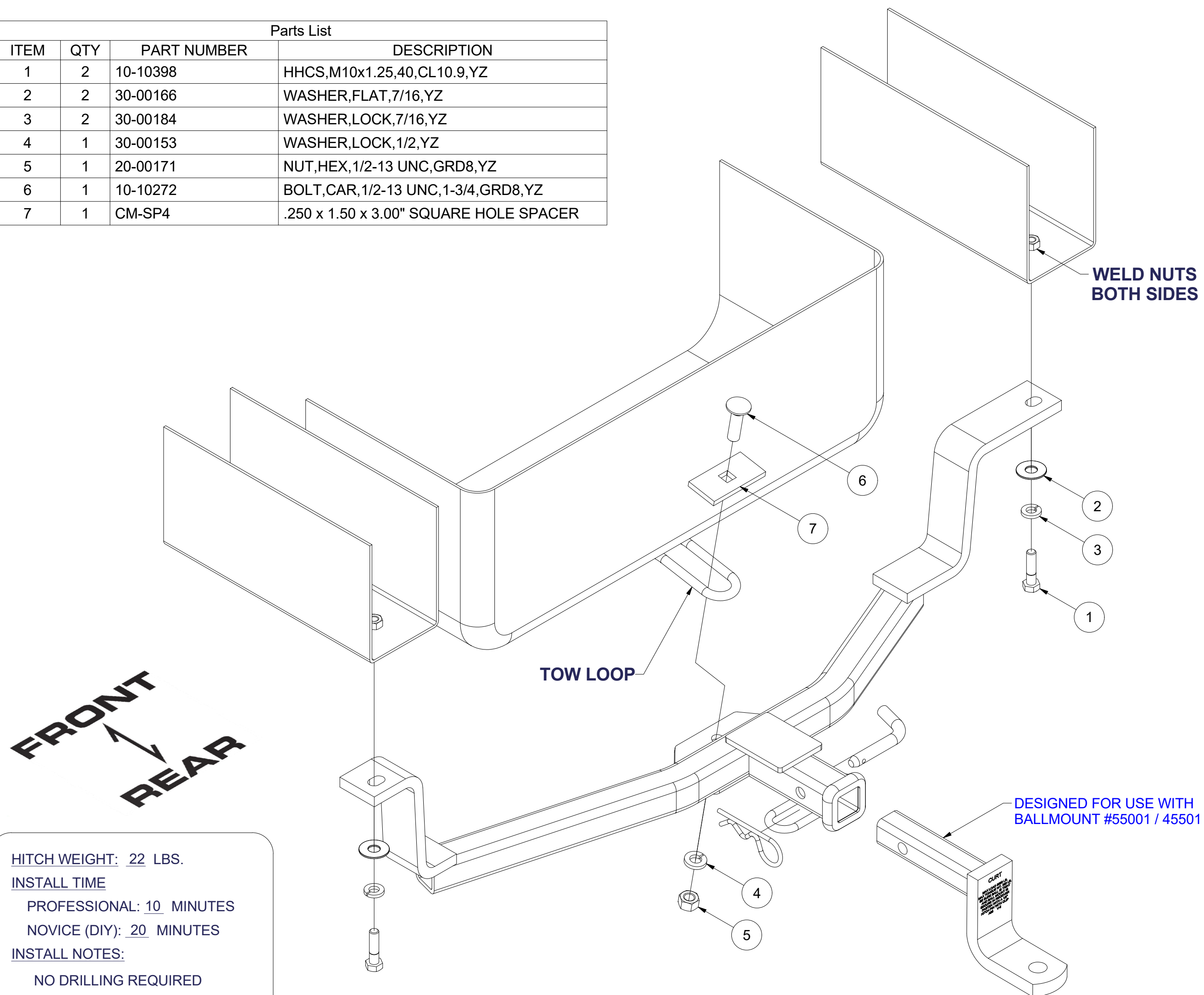

HITCH WEIGHT: 22 LBS.

INSTALL TIME

PROFESSIONAL: 10 MINUTES

NOVICE (DIY): 20 MINUTES

INSTALL NOTES:

NO DRILLING REQUIRED

INSTALLATION STEPS

- 1) Remove existing M10 bolts from weld nuts in frame.
- 2) Attach the hitch to the tow loop with the 1/2" hardware and the tow loop plate as shown.
- 3) Using the new fasteners provided, fasten the hitch to the frame. Do not tighten.
- 4) Tighten all bolts to the following specifications:

M10 = 48 ft-lbs

1/2" = 110 ft-lbs

PERIODICALLY CHECK THIS RECEIVER HITCH TO ENSURE THAT ALL FASTENERS ARE TIGHT AND THAT ALL STRUCTURAL COMPONENTS ARE SOUND.

Curt Manufacturing Inc., warrants this product to be free of defects in material and/or workmanship at the time of retail purchase by the original purchaser. If the product is found to be defective, Curt Manufacturing Inc., may repair or replace the product, at their option, when the product is returned, prepaid, with proof of purchase. Alteration to, misuse of, or improper installation of this product voids the warranty. Curt Manufacturing Inc.'s liability is limited to repair or replacement of products found to be defective, and specifically excludes liability for incidental or consequential loss or damage.