

11215

90-94 HYUNDAI EXCEL HATCHBACK/SEDAN
91-95 HYUNDAI SCOUPE / 90-93 MITSUBISHI PRECIS

12/10/2012

GROSS LOAD CAPACITY WHEN USED AS A WEIGHT CARRYING HITCH: 2,000 LBS. TRAILER WEIGHT & 200 LBS. TONGUE WEIGHT.

DO NOT EXCEED VEHICLE MANUFACTURER'S RECOMMENDED TOWING CAPACITY.

WARNING: ALL NON-TRAILER LOADS APPLIED TO THIS PRODUCT MUST BE SUPPORTED BY 18050 STABILIZING STRAPS.

** FAILURE TO PROPERLY SUPPORT NON-TRAILER LOADS WILL VOID PRODUCT WARRANTY**

HAVING INSTALLATION QUESTIONS? CALL TECHNICAL SUPPORT AT 1-877-287-8634

THIS HITCH USES ALL EXISTING FASTENERS

RUBBER ISOLATOR REMOVAL DIAGRAM

This technique can be used if and Exhaust Hanger Removal Pliers is not available.

Using a 5/8" open end wrench, slide the wrench up to the rubber isolator, cradling the hanger rod as shown. Next place the flat edge of a pry bar between the wrench and the hanger stop or hanger rod. Then simply rotate the pry bar toward the wrench to remove the rubber isolator.

Note: Using a spray lubricant or soapy water on the hanger rod and the rubber isolator helps removal.

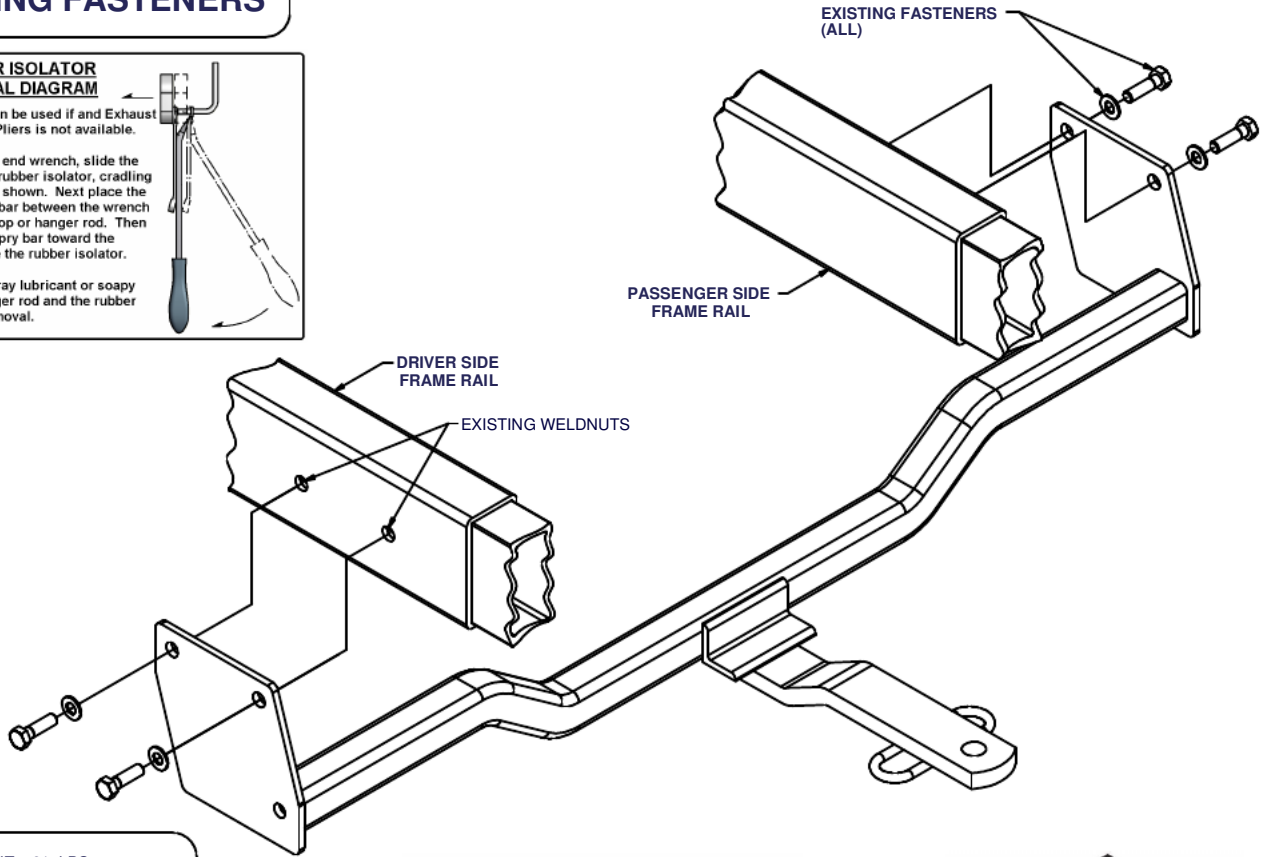
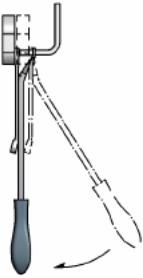

HITCH WEIGHT: 21 LBS.

INSTALL TIME

PROFESSIONAL: 30 MINUTES

NOVICE (DIY): 60 MINUTES

INSTALL NOTES:

- NO DRILLING REQUIRED
- LOWER EXHAUST
- REMOVE TIE DOWN BRACKETS

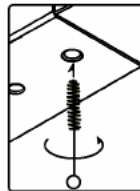

WELDNUT CLEANING

To remove debris from weldnuts in frame, spray lubricant or compressed air into hole. For heavy debris, use a small wire brush. (Be careful not to damage threads).

FRONT
↑
REAR

INSTALLATION STEPS

1. Underneath the rear of the vehicle, locate the driver and passenger side tie down brackets (vertical plates) bolted to the frame rails. Remove both brackets (2 bolt/washer assemblies per side) and return the brackets to the vehicle owner for reinstallation should the hitch ever be removed. NOTE: These existing bolt/washer assemblies will be reinstalled to secure the hitch and the rear bumper to frame.
2. To ease installation, temporarily lower the exhaust by disconnecting the rearmost exhaust hangers. The hitch fastens to the vehicle frame where the brackets were removed. Raise the hitch into position above the exhaust and attach to the vehicle frame with existing fasteners.
3. Torque all 10mm fasteners to 48 lb-ft, or 12mm fasteners to 86 lb-ft.
4. Raise exhaust back into position.

PERIODICALLY CHECK THIS RECEIVER HITCH TO ENSURE THAT ALL FASTENERS ARE TIGHT AND THAT ALL STRUCTURAL COMPONENTS ARE SOUND.

Curt Manufacturing Inc., warrants this product to be free of defects in material and/or workmanship at the time of retail purchase by the original purchaser. If the product is found to be defective, Curt Manufacturing Inc., may repair or replace the product, at their option, when the product is returned, prepaid, with proof of purchase. Alteration to, misuse of, or improper installation of this product voids the warranty. Curt Manufacturing Inc.'s liability is limited to repair or replacement of products found to be defective, and specifically excludes liability for incidental or consequential loss or damage.