

11208

1992-2002 HONDA PRELUDE COUPE

9/21/2020

GROSS LOAD CAPACITY WHEN USED AS A WEIGHT CARRYING HITCH: 2,000 LBS. TRAILER WEIGHT & 200 LBS. TONGUE WEIGHT.

DO NOT EXCEED VEHICLE MANUFACTURER'S RECOMMENDED TOWING CAPACITY.

WARNING: ALL NON-TRAILER LOADS APPLIED TO THIS PRODUCT MUST BE SUPPORTED BY AUXILIARY STABILIZING STRAPS.

** FAILURE TO PROPERLY SUPPORT NON-TRAILER LOADS WILL VOID PRODUCT WARRANTY**

HAVING INSTALLATION QUESTIONS? CALL TECHNICAL SUPPORT AT 1-877-287-8634

Parts List				
ITEM	QTY	PART NUMBER	DESCRIPTION	
1	4	10-10282	BOLT,CAR,7/16-14 UNC,1-1/2,GRD8,YZ	
2	4	CM-SP108	2.00 X 0.88 X .125 SPACER	
3	4	20-00103	NUT,SER-FLANGE,7/16-14 UNC,GRD8,YZ	
4	2	10-10271	HHCS,M10x1.25,30,CL10.9,YZ	
5	2	30-00163	WASHER, S-CON,7/16,YZ	
6	2	20-00195	M10-1.25 HEX FLANGE NUT	
7	2	7_16 FISHWIRE	7/16" FISHWIRE	

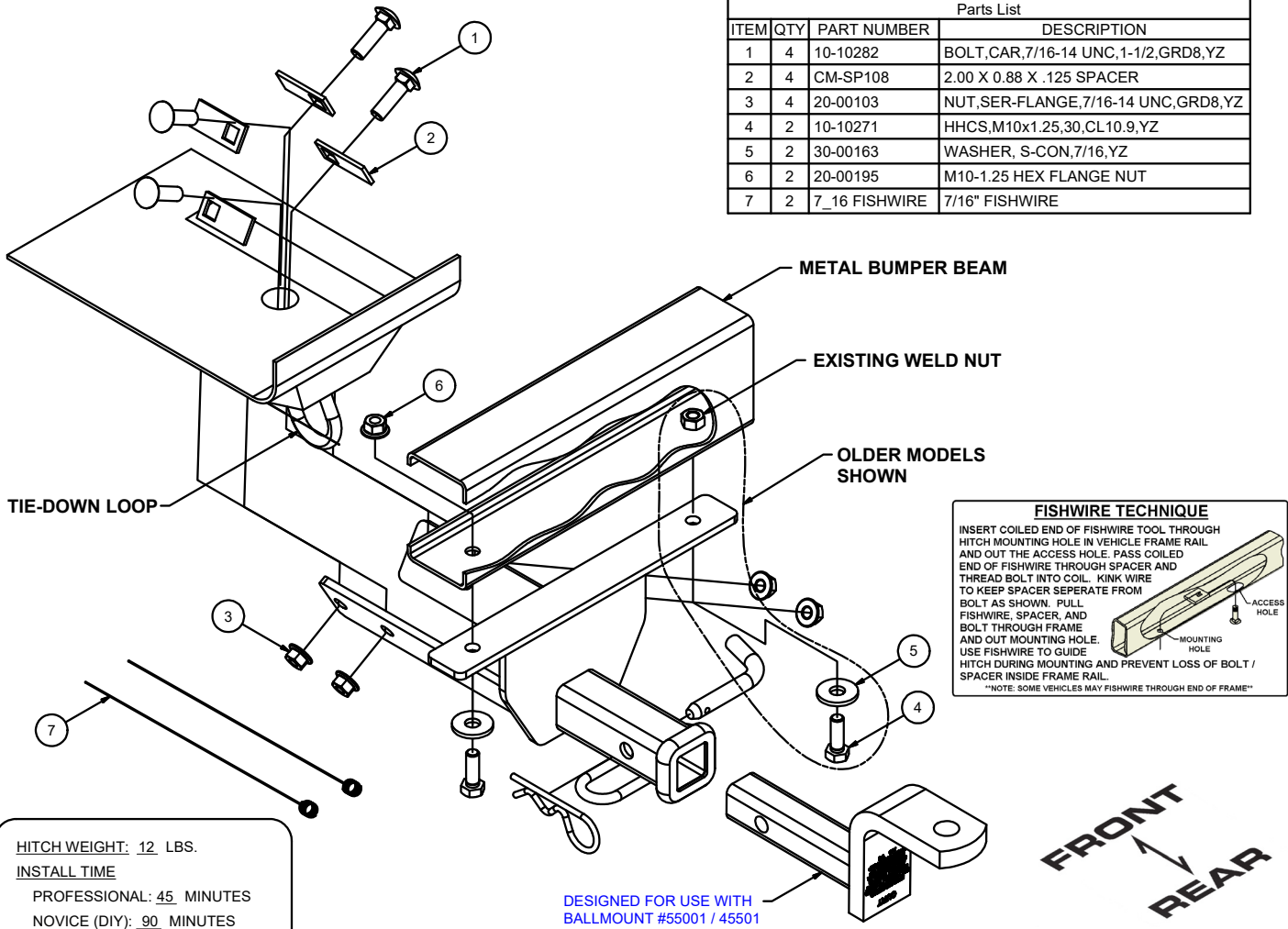

HITCH WEIGHT: 12 LBS.
INSTALL TIME
 PROFESSIONAL: 45 MINUTES
 NOVICE (DIY): 90 MINUTES
INSTALL NOTES:
 - DRILLING REQUIRED
 - FISHWIRE HARDWARE

DESIGNED FOR USE WITH BALLMOUNT #55001 / 45501

INSTALLATION STEPS

1. This hitch mounts to the bottom of the metal bumper beam and to the sides of the tie-down loop reinforcement at the bottom center of the floor pan.
2. Place the hitch centered and square on the bumper beam with the tail brackets on both sides of the tie-down loop. Using the hitch as a template, mark the bumper beam for fasteners as shown. NOTE: Older models have existing weld nuts in the bumper beam for fasteners as shown.
3. Remove the hitch, and drill for fasteners. Place the hitch over the holes and install fasteners.
4. With the hitch level on the car, use the hitch as a template and drill four holes through the sides of the tie-down reinforcement for fasteners. From the inside of the car, locate the floor area over the tie-down reinforcement. Make an access hole to allow fishwiring of fasteners into place as shown. Install remaining fasteners, as shown.
5. Torque all 7/16" hardware to 70 ft-lbs. Torque all M10 hardware to 48 ft-lbs.

PERIODICALLY CHECK THIS RECEIVER HITCH TO ENSURE THAT ALL FASTENERS ARE TIGHT AND THAT ALL STRUCTURAL COMPONENTS ARE SOUND.

Curt Manufacturing Inc., warrants this product to be free of defects in material and/or workmanship at the time of retail purchase by the original purchaser. If the product is found to be defective, Curt Manufacturing Inc., may repair or replace the product, at their option, when the product is returned, prepaid, with proof of purchase. Alteration to, misuse of, or improper installation of this product voids the warranty. Curt Manufacturing Inc.'s liability is limited to repair or replacement of products found to be defective, and specifically excludes liability for incidental or consequential loss or damage.