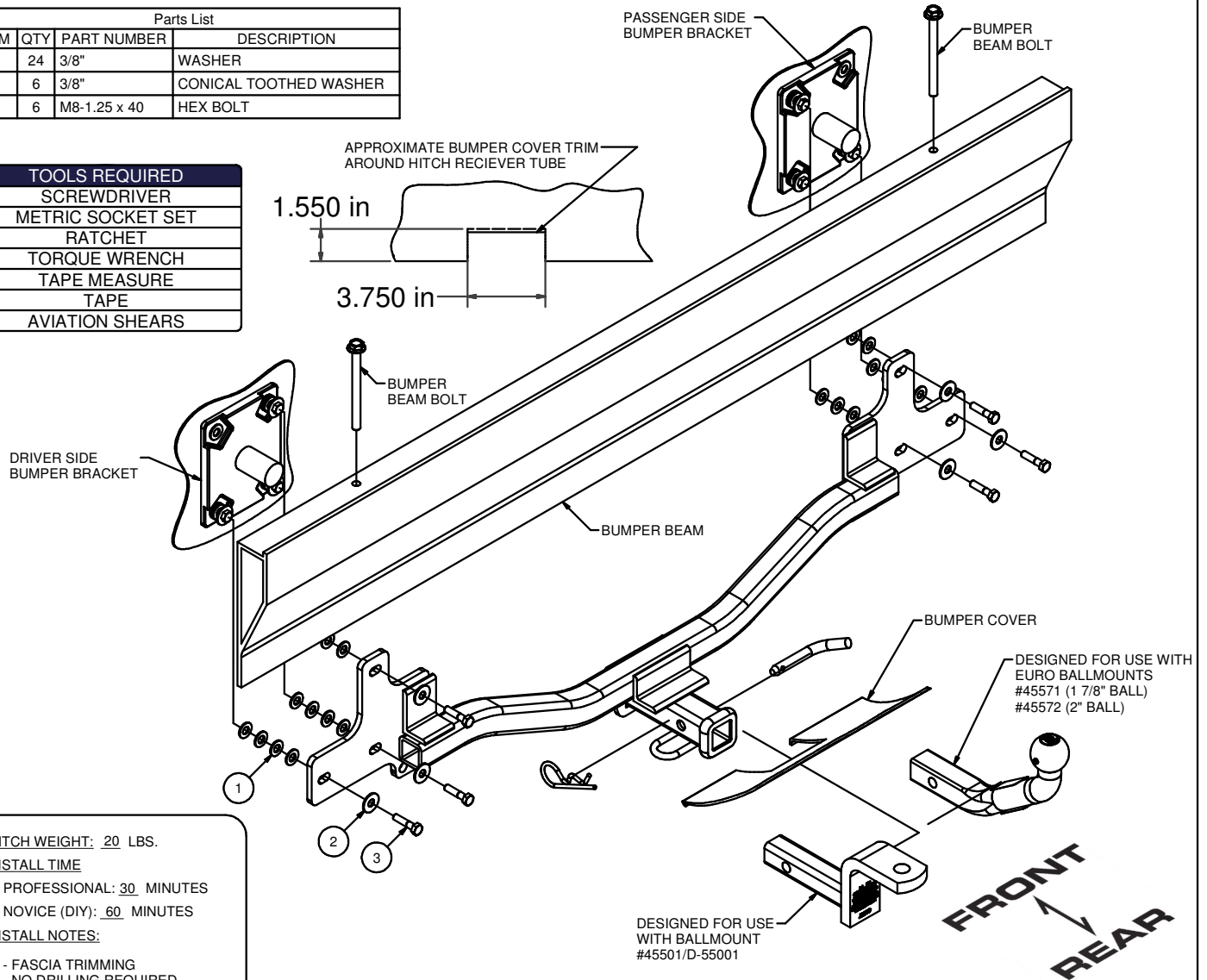

11199**AUDI A8****3/21/13****GROSS LOAD CAPACITY WHEN USED AS A WEIGHT CARRYING HITCH: 1,500 LBS. TRAILER WEIGHT & 150 LBS. TONGUE WEIGHT.*******DO NOT EXCEED VEHICLE MANUFACTURER'S RECOMMENDED TOWING CAPACITY.*******WARNING: ALL NON-TRAILER LOADS APPLIED TO THIS PRODUCT MUST BE SUPPORTED BY 18050 STABILIZING STRAPS.****** FAILURE TO PROPERLY SUPPORT NON-TRAILER LOADS WILL VOID PRODUCT WARRANTY******HAVING INSTALLATION QUESTIONS? CALL TECHNICAL SUPPORT AT 1-800-798-0813**

Parts List			
ITEM	QTY	PART NUMBER	DESCRIPTION
1	24	3/8"	WASHER
2	6	3/8"	CONICAL TOOTHED WASHER
3	6	M8-1.25 x 40	HEX BOLT

TOOLS REQUIRED
SCREWDRIVER
METRIC SOCKET SET
RATCHET
TORQUE WRENCH
TAPE MEASURE
TAPE
AVIATION SHEARS

**HITCH WEIGHT: 20 LBS.****INSTALL TIME**PROFESSIONAL: **30** MINUTESNOVICE (DIY): **60** MINUTES**INSTALL NOTES:**

- FASCIA TRIMMING
- NO DRILLING REQUIRED

INSTALLATION STEPS

1. To remove bumper cover: remove the (4) bolts from the underside of the bumper cover, and remove the (3) hex bolts on the inside of the wheelwell liners.
2. On the inside of side panel is (1) nut on each side which must be unscrewed. Release mounting strips on both side panels and pull off cover gently toward rear.
3. When rear fascia is removed, rear bumper beam will be exposed. The bumper beam can be removed by removing (2) bolts at the top of each side of the frame mounting bracket.
4. Raise hitch into position, attaching to inside and bottom M8 mounting points on frame mounting pad (3) places each side. (4) washers will be stacked at each mounting point to create a flush mounting surface for the hitch.
5. Torque all M8 hardware to 23 lb-ft.
6. Reattach rear bumper beam using vehicle hardware through top of frame mounting bracket.
7. Trim fascia as necessary above hitch receiver tube and reattach into position by following the steps 1-2 in reverse.

PERIODICALLY CHECK THIS RECEIVER HITCH TO ENSURE THAT ALL FASTENERS ARE TIGHT AND THAT ALL STRUCTURAL COMPONENTS ARE SOUND.

Curt Manufacturing LLC., warrants this product to be free of defects in material and/or workmanship at the time of retail purchase by the original purchaser. If the product is found to be defective, Curt Manufacturing LLC., may repair or replace the product, at their option, when the product is returned, prepaid, with proof of purchase. Alteration to, misuse of, or improper installation of this product voids the warranty. Curt Manufacturing LLC.'s liability is limited to repair or replacement of products found to be defective, and specifically excludes liability for incidental or consequential loss or damage.