

**11182****06-07 BMW 530XI WAGON**

11/30/2012

GROSS LOAD CAPACITY WHEN USED AS A WEIGHT CARRYING HITCH: 2,000 LBS. TRAILER WEIGHT & 200 LBS. TONGUE WEIGHT.  
**\*\*\*DO NOT EXCEED VEHICLE MANUFACTURER'S RECOMMENDED TOWING CAPACITY.\*\*\***

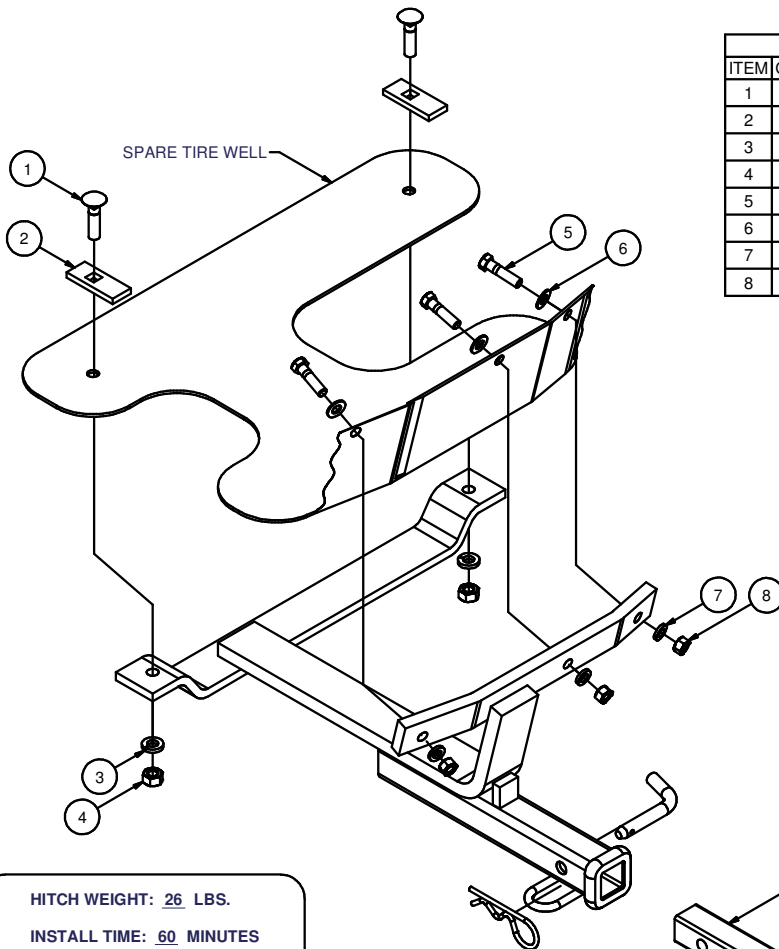

Parts List			
ITEM	QTY	PART NUMBER	DESCRIPTION
1	2	7/16 - 14 x 1 3/4	CARRIAGE BOLT
2	2	CM-SP11	.250 x 1.00 x 2.50" SQUARE HOLE SPACER
3	2	7/16 LOCK WASHER	HELICAL LOCK WASHER
4	2	7/16-14	HEX NUT
5	3	3/8-16 X 1 1/2	HEX BOLT
6	3	3/8"	WASHER
7	3	3/8"	LOCK WASHER
8	3	3/8 - 16	HEX NUT

HITCH WEIGHT: 26 LBS.INSTALL TIME: 60 MINUTES

INSTALL NOTES:

- DRILLING REQUIRED

**INSTALLATION STEPS**

- 1) Remove or elevate floor panels inside trunk/rear compartment and clear contents of tire well. Note two holes will be drilled on outside of rails running to front/back of vehicle. (Disregard step 2 to if you have a right-angle drill.)
- 2) In rear tire wells locate and remove two clips, gravel shield, three plastic pin fasteners per side. Slide bumper assembly with fascia off to the rear.
- 3) Carefully locate center of vehicle and mark. Position hitch as shown with rear bracket snug under body ledge and hitch receiver exactly centered on vehicle. Use hitch as template to mark body five places for drill locations.
- 4) Center punch and drill car two places for 7/16" diameter bolts and three places for 3/8" diameter bolts. Apply silicon around holes to prevent exhaust fumes from entering vehicle. Place bolts and flat washers on inside of vehicle with lock washers and nuts on outside of vehicle. (Washers may have to conform to panel upon tightening.)
- 5) Torque all 3/8"-16 hardware to 45 lb-ft. and all 7/16"-14 hardware to 70 lb-ft.

**PERIODICALLY CHECK THIS RECEIVER HITCH TO ENSURE THAT ALL FASTENERS ARE TIGHT AND THAT ALL STRUCTURAL COMPONENTS ARE SOUND.**

Curt Manufacturing Inc., warrants this product to be free of defects in material and/or workmanship at the time of retail purchase by the original purchaser. If the product is found to be defective, Curt Manufacturing Inc., may repair or replace the product, at their option, when the product is returned, prepaid, with proof of purchase. Alteration to, misuse of, or improper installation of this product voids the warranty. Curt Manufacturing Inc.'s liability is limited to repair or replacement of products found to be defective, and specifically excludes liability for incidental or consequential loss or damage.