

**11179****99-03 BMW 5 SERIES SEDAN & WAGON****9/29/2020**

GROSS LOAD CAPACITY WHEN USED AS A WEIGHT CARRYING HITCH: 2,000 LBS. TRAILER WEIGHT &amp; 200 LBS. TONGUE WEIGHT.

**\*\*\*DO NOT EXCEED VEHICLE MANUFACTURER'S RECOMMENDED TOWING CAPACITY.\*\*\*****WARNING: ALL NON-TRAILER LOADS APPLIED TO THIS PRODUCT MUST BE SUPPORTED BY AUXILIARY STABILIZING STRAPS.****\*\* FAILURE TO PROPERLY SUPPORT NON-TRAILER LOADS WILL VOID PRODUCT WARRANTY\*\***

HAVING INSTALLATION QUESTIONS? CALL TECHNICAL SUPPORT AT 1-877-287-8634

Parts List			
ITEM	QTY	PART NUMBER	DESCRIPTION
1	4	10-10234	HHCS,3/8-16 UNC,1-1/2,GRD8,YZ
2	4	30-00186	WASHER,FLAT,3/8,YZ
3	4	30-00130	WASHER,LOCK,3/8,YZ
4	4	20-00166	NUT,HEX,3/8-16 UNC,GRD8,YZ
5	2	10-10314	BOLT,CAR,7/16-14 UNC,1-3/4,GRD8,YZ
6	2	30-00184	WASHER,LOCK,7/16,YZ
7	2	20-00147	NUT,HEX,7/16-14 UNC,GRD8,YZ
8	2	CM-SP11	.250 x 1.00 x 2.50" SQUARE HOLE SPACER

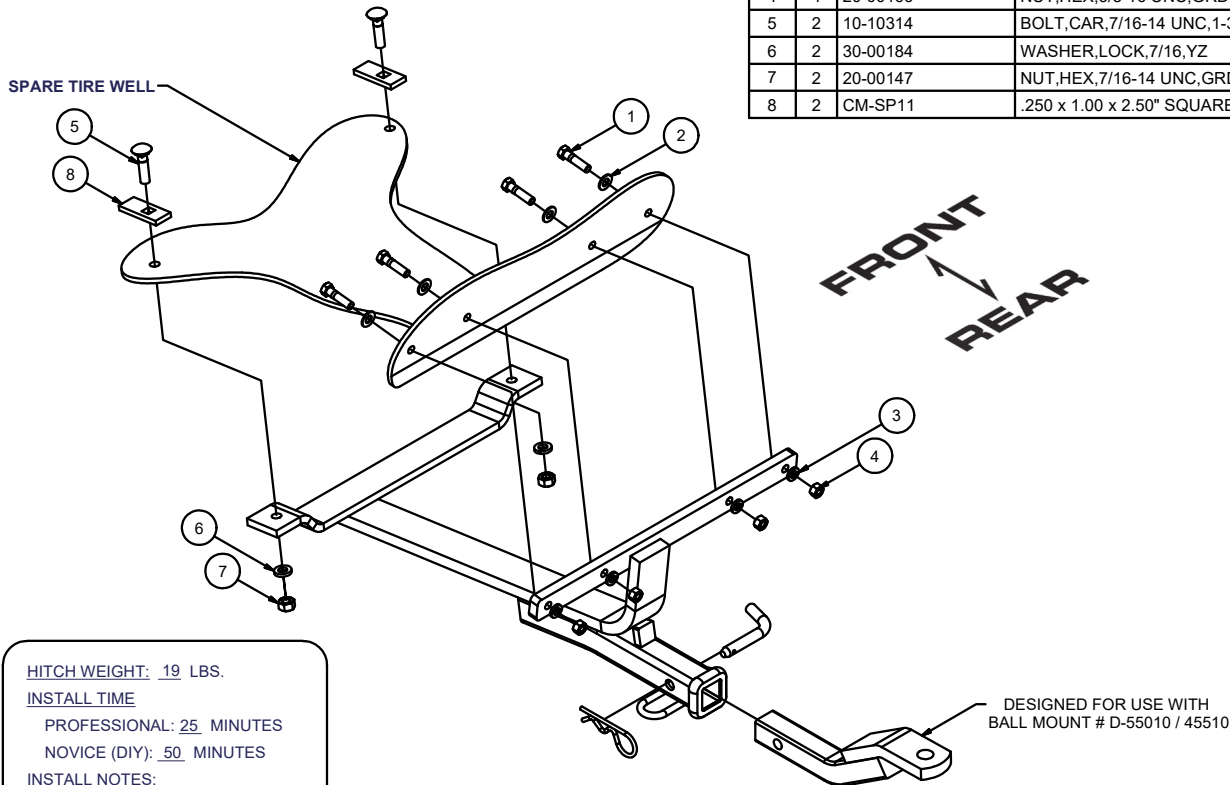
HITCH WEIGHT: 19 LBS.**INSTALL TIME**PROFESSIONAL: 25 MINUTESNOVICE (DIY): 50 MINUTES**INSTALL NOTES:**

- DRILLING REQUIRED
- REMOVE BUMPER

**INSTALLATION STEPS**

1. Remove or elevate floor panels inside trunk/rear compartment and clear contents of tire well. Note on either side of tire well formed metal "rails" running fore/aft inside trunk/rear compartment. Locate point inside car where rails meet rear of body and find three "nuts with integral washers" on both rails for a total of six. Remove nuts.
2. At rear of wheel opening (outside car) locate and remove two "clips", gravel shield, three plastic "pin fasteners" per side. Bumper assembly with fascia should now slide off to the rear. Reinstallation is reverse of removal.
3. Carefully locate center of vehicle and mark. Position hitch as shown with rear bracket snug under body ledge and hitch receiver exactly centered on car. Use hitch as template to mark body six places for 3/8" diameter mounting screws.
4. Center punch and drill car two places for 7/16" diameter screws, and four places for 3/8" diameter screws. Place screws and flat washers from inside the car, washers may have to conform to panel detail upon tightening.
5. Torque 3/8" fasteners to 45 ft-lbs. and 7/16" fasteners to 70 ft-lbs.

**PERIODICALLY CHECK THIS RECEIVER HITCH TO ENSURE THAT ALL FASTENERS ARE TIGHT AND THAT ALL STRUCTURAL COMPONENTS ARE SOUND.**

Curt Manufacturing Inc., warrants this product to be free of defects in material and/or workmanship at the time of retail purchase by the original purchaser. If the product is found to be defective, Curt Manufacturing Inc., may repair or replace the product, at their option, when the product is returned, prepaid, with proof of purchase. Alteration to, misuse of, or improper installation of this product voids the warranty. Curt Manufacturing Inc.'s liability is limited to repair or replacement of products found to be defective, and specifically excludes liability for incidental or consequential loss or damage.