

**11167**

92-94 AUDI 100, 95-97 A6 QUATTRO, 95-98 A6 AVANT

11/13/2017

GROSS LOAD CAPACITY WHEN USED AS A WEIGHT CARRYING HITCH: 2,000 LBS. TRAILER WEIGHT &amp; 200 LBS. TONGUE WEIGHT.

**\*\*\*DO NOT EXCEED VEHICLE MANUFACTURER'S RECOMMENDED TOWING CAPACITY.\*\*\***

WARNING: ALL NON-TRAILER LOADS APPLIED TO THIS PRODUCT MUST BE SUPPORTED BY AUXILIARY STABILIZING STRAPS.

**\*\* FAILURE TO PROPERLY SUPPORT NON-TRAILER LOADS WILL VOID PRODUCT WARRANTY\*\***

HAVING INSTALLATION QUESTIONS? CALL TECHNICAL SUPPORT AT 1-877-287-8634

Parts List			
ITEM	QTY	PART NUMBER	DESCRIPTION
1	6	7/16-14	HEX NUT
2	6	7/16-14 x 2	CARRIAGE BOLT
3	6	7/16 LOCK WASHER	HELICAL LOCK WASHER
4	4	CM-SP25	.250 x 1.38 x 1.50" ROUND HOLE SPACER
5	2	CM-11167-FP	.375" FRAME PLATE
6	2	CM-11167-SP	1.500 x .188" SPACER

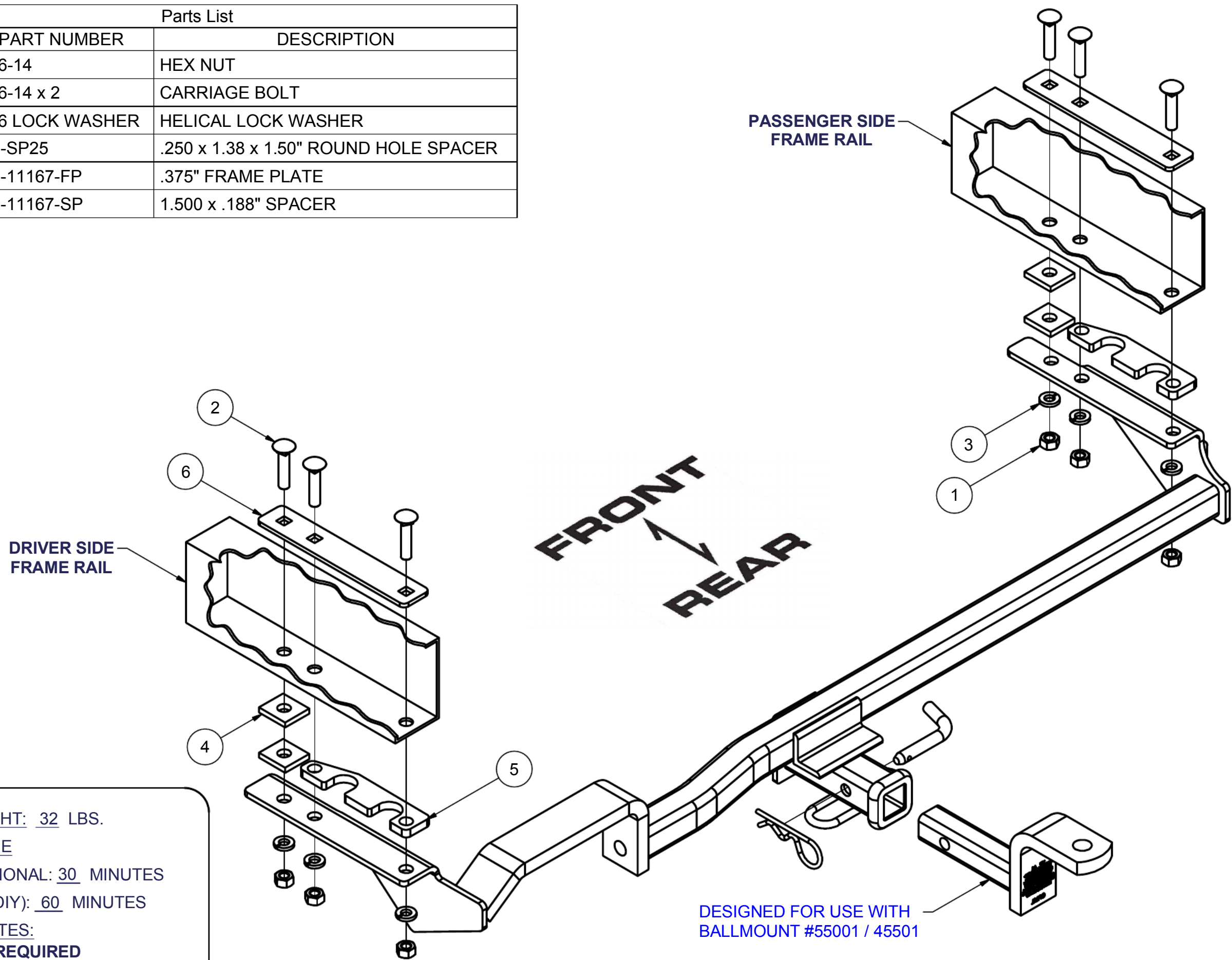

HITCH WEIGHT: 32 LBS.

**INSTALL TIME**

PROFESSIONAL: 30 MINUTES

NOVICE (DIY): 60 MINUTES

**INSTALL NOTES:**

- DRILLING REQUIRED
- REMOVE AND REINSTALL BUMPER

DESIGNED FOR USE WITH  
BALLMOUNT #55001 / 45501**INSTALLATION STEPS**

1. Remove the car's rear bumper by removing three bolts from each flange where the bumper brackets (energy absorbers) attach to chassis. Pull bumper straight back and off of the car. You now have access to the inside of the car's left and right frame rails.
2. Temporarily mount the hitch using existing holes at rear of frame rails. The hitch will fit to the bottom surface of the frame rails. Do not use backing plates at this time.
3. Using the hitch as a template, drill the bottom surface of the car's frame rails with a 7/16" bit. Remove the hitch from the car.
4. place three carriage bolts in the holes in each backing plate. Place one backing plate with bolts inside each frame rail so carriage bolts drop through the holes in the frame rail bottom surface.
5. Reposition hitch on car being careful not to push carriage bolts out of place. Install nuts and lock washers onto bolts.
6. Torque all hardware to 70 lb-ft.
7. Reinstall bumper.

**PERIODICALLY CHECK THIS RECEIVER HITCH TO ENSURE THAT ALL FASTENERS ARE TIGHT AND THAT ALL STRUCTURAL COMPONENTS ARE SOUND.**

Curt Manufacturing Inc., warrants this product to be free of defects in material and/or workmanship at the time of retail purchase by the original purchaser. If the product is found to be defective, Curt Manufacturing Inc., may repair or replace the product, at their option, when the product is returned, prepaid, with proof of purchase. Alteration to, misuse of, or improper installation of this product voids the warranty. Curt Manufacturing Inc.'s liability is limited to repair or replacement of products found to be defective, and specifically excludes liability for incidental or consequential loss or damage.