

11166

98-04 AUDI A6 SEDAN, QUATTRO ONLY, 99-04 A6 AVANT WAGON, QUATTRO, 01-05 AUDI ALLROAD QUATTRO WAGON

3/3/2021

GROSS LOAD CAPACITY WHEN USED AS A WEIGHT CARRYING HITCH: 2,000 LBS. TRAILER WEIGHT & 200 LBS. TONGUE WEIGHT.

*****DO NOT EXCEED VEHICLE MANUFACTURER'S RECOMMENDED TOWING CAPACITY.*****

WARNING: ALL NON-TRAILER LOADS APPLIED TO THIS PRODUCT MUST BE SUPPORTED BY AUXILIARY STABILIZING STRAPS.

**** FAILURE TO PROPERLY SUPPORT NON-TRAILER LOADS WILL VOID PRODUCT WARRANTY****

HAVING INSTALLATION QUESTIONS? CALL TECHNICAL SUPPORT AT 877-287-8634

Parts List			
ITEM	QTY	PART NUMBER	DESCRIPTION
1	4	20-00102	NUT,SER-FLANGE,3/8-16 UNC,GRD8,YZ
2	2	10-10415	HHCS,7/16-14 UNC,1-1/2,GRD8,YZ
3	2	30-00166	WASHER,FLAT,7/16,YZ
4	2	20-00103	NUT,SER-FLANGE,7/16-14 UNC,GRD8,YZ
5	4	10-10339	HHCS,3/8-16 UNC,1-1/4,GRD8,YZ

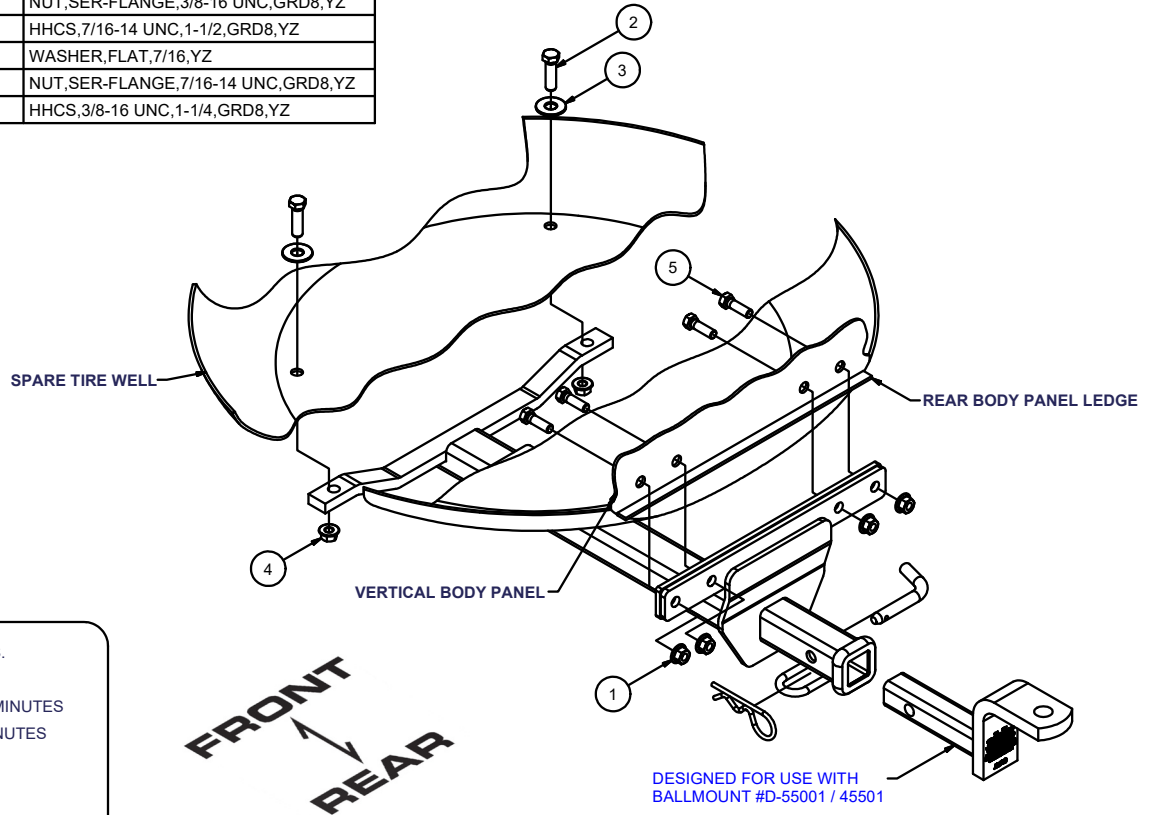

HITCH WEIGHT: 19 LBS.

INSTALL TIME

PROFESSIONAL: 45 MINUTES

NOVICE (DIY): 90 MINUTES

INSTALL NOTES:

-DRILLING REQUIRED

-FASCIA REMOVAL

INSTALLATION STEPS

A6 SEDAN AND AVANT WAGON

- 1) Temporarily remove spare tire and rear bumper cover (fascia). Remove fasteners attaching lower gravel shield to bottom edge of bumper fascia. Inside the trunk locate and remove five flange nuts on each side on the rear body panel. On the outside of the car near the wheel openings, locate and remove two screws on each side attaching the bumper fascia. Carefully slide bumper fascia straight off.
- 2) Lift hitch into position between tire well and lower gravel shield. Center hitch left to right and rest on rear body panel ledge, as shown. Using hitch as a template, mark and drill holes for all fasteners. Four holes in rear body panel and two in spare tire well.
- 3) Install 3/8" fasteners with reinforcement plate to rear body panel inside trunk area, as shown. Fasten hitch to tire well with 7/16" fasteners, as shown.

AUDI ALLROAD QUATTRO WAGON

- 1) Temporarily remove the lower panel of rear bumper (between exhaust tips) by turning four 1/2 turn fasteners. Do not remove entire rear bumper.
- 2) Lift hitch into position centered left to right on car and resting on rear body panel ledge, as shown. Using hitch as a template, mark and drill two inner holes (closer to center) at rear body panel and two at the tire well.
- 3) Install two 3/8" fasteners and reinforcement plates at rear body panel. Install two 7/16" fasteners inside tire well.
- 4) From inside trunk, use outer hole in reinforcement plate as a template to drill through rear body panel. Install remaining fasteners as shown.

ALL MODELS:

Torque all 3/8" fasteners to 45 lb.-ft. and all 7/16" fasteners to 59 lb.-ft. Carefully replace bumper fascia or lower panel, spare tire, and any other objects removed for installation.

PERIODICALLY CHECK THIS RECEIVER HITCH TO ENSURE THAT ALL FASTENERS ARE TIGHT AND THAT ALL STRUCTURAL COMPONENTS ARE SOUND.

Curt Manufacturing Inc., warrants this product to be free of defects in material and/or workmanship at the time of retail purchase by the original purchaser. If the product is found to be defective, Curt Manufacturing Inc., may repair or replace the product, at their option, when the product is returned, prepaid, with proof of purchase. Alteration to, misuse of, or improper installation of this product voids the warranty. Curt Manufacturing Inc.'s liability is limited to repair or replacement of products found to be defective, and specifically excludes liability for incidental or consequential loss or damage.