

11155

96-98 ACURA TL

11/10/2017

GROSS LOAD CAPACITY WHEN USED AS A WEIGHT CARRYING HITCH: 2,000 LBS. TRAILER WEIGHT & 200 LBS. TONGUE WEIGHT.

DO NOT EXCEED VEHICLE MANUFACTURER'S RECOMMENDED TOWING CAPACITY.

WARNING: ALL NON-TRAILER LOADS APPLIED TO THIS PRODUCT MUST BE SUPPORTED BY 18050 STABILIZING STRAPS.

** FAILURE TO PROPERLY SUPPORT NON-TRAILER LOADS WILL VOID PRODUCT WARRANTY**

HAVING INSTALLATION QUESTIONS? CALL TECHNICAL SUPPORT AT 1-877-287-8634

Parts List			
ITEM	QTY	PART NUMBER	DESCRIPTION
1	1	CM-438-FW	7/16" FISHWIRE TOOL
2	2	M10 - 1.25 x 25	HEX BOLT
3	2	3/8"	CONICAL TOOTHED WASHER
4	2	7/16-14	HEX FLANGE NUT
5	2	CM-SP108	2.00 X 0.88 X .125 SPACER
6	2	7/16-14 x 1 1/2	CARRIAGE BOLT

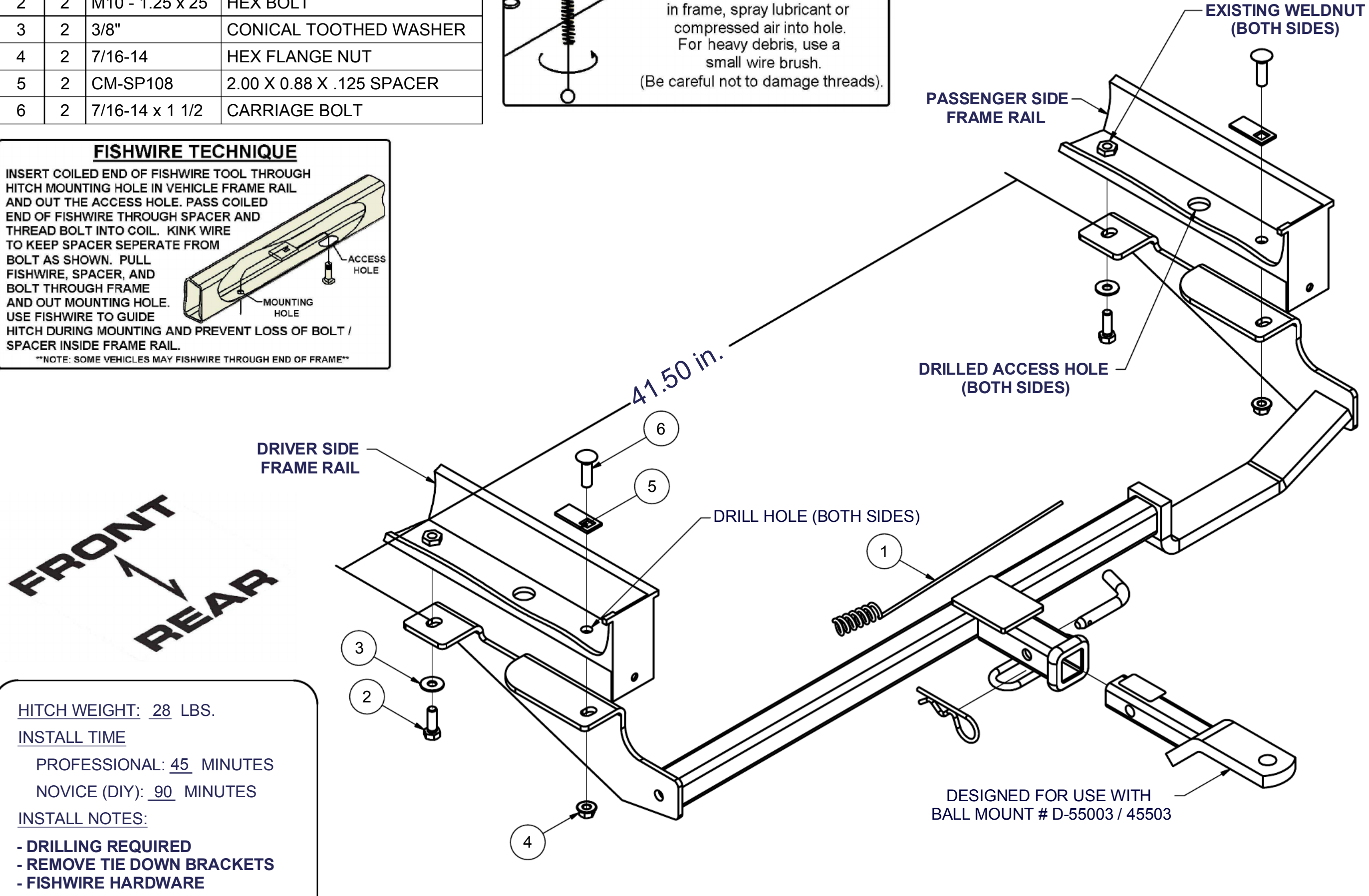
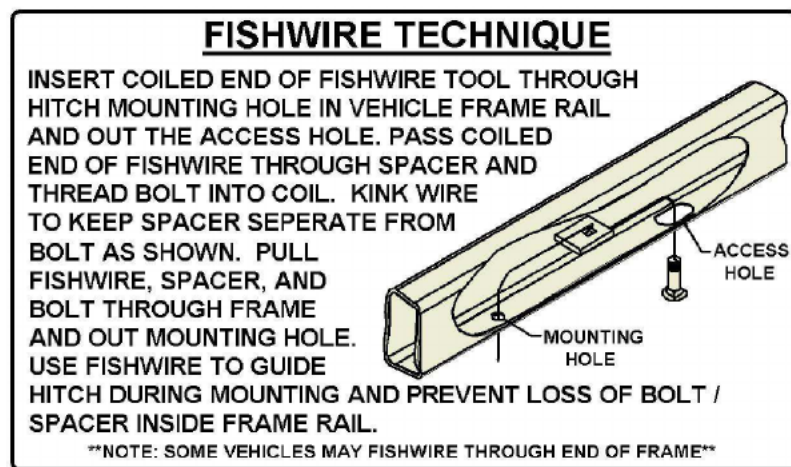
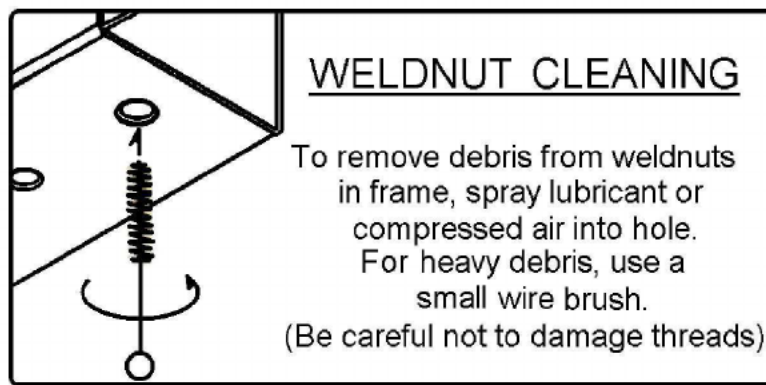

HITCH WEIGHT: 28 LBS.
INSTALL TIME
PROFESSIONAL: 45 MINUTES
NOVICE (DIY): 90 MINUTES
INSTALL NOTES:
- DRILLING REQUIRED
- REMOVE TIE DOWN BRACKETS
- FISHWIRE HARDWARE

INSTALLATION STEPS

1. Locate driver and passenger side frame rails under rear of vehicle. Remove (1) tie down bracket from each frame rail. Replace the front most bracket bolt.
2. Lift hitch into position. Temporarily mount hitch to existing weldnuts. Use hitch as a template to drill 1/2" diameter holes for carriage bolts in rear slots. Remove hitch.
3. Using a 1" hole saw, make one access hole in bottom surface of each frame rail. Locate as shown in diagram so the access hole will be covered by the hitch side plate when hitch is installed. This hole is used to fishwire carriage bolts and spacers into the frame rails.
4. Fishwire 7/16" carriage bolts and CM-SP108 through access holes and out drilled holes as shown.
5. Reinstall the hitch on vehicle being careful not to push carriage bolts into frame rails. Reinstall M10 bolts and 3/8" conical toothed washers into weldnuts as shown.
6. Torque all 10mm bolts to 48 lb.-ft. and all 7/16" hardware to 70 lb.-ft.

PERIODICALLY CHECK THIS RECEIVER HITCH TO ENSURE THAT ALL FASTENERS ARE TIGHT AND THAT ALL STRUCTURAL COMPONENTS ARE SOUND.

Curt Manufacturing Inc., warrants this product to be free of defects in material and/or workmanship at the time of retail purchase by the original purchaser. If the product is found to be defective, Curt Manufacturing Inc., may repair or replace the product, at their option, when the product is returned, prepaid, with proof of purchase. Alteration to, misuse of, or improper installation of this product voids the warranty. Curt Manufacturing Inc.'s liability is limited to repair or replacement of products found to be defective, and specifically excludes liability for incidental or consequential loss or damage.