

11150**89-95 MAZDA MPV VAN**

11/10/2017

GROSS LOAD CAPACITY WHEN USED AS A WEIGHT CARRYING HITCH: 2,000 LBS. TRAILER WEIGHT & 200 LBS. TONGUE WEIGHT.

*****DO NOT EXCEED VEHICLE MANUFACTURER'S RECOMMENDED TOWING CAPACITY.*****

WARNING: ALL NON-TRAILER LOADS APPLIED TO THIS PRODUCT MUST BE SUPPORTED BY 18050 STABILIZING STRAPS.

**** FAILURE TO PROPERLY SUPPORT NON-TRAILER LOADS WILL VOID PRODUCT WARRANTY****

HAVING INSTALLATION QUESTIONS? CALL TECHNICAL SUPPORT AT 1-877-287-8634

Parts List				
ITEM	QTY	PART NUMBER	DESCRIPTION	
1	2	5/8-11 x 1 1/2 HEX BOLT	5/8-11 HEX BOLT	
2	2	5/8	WASHER	
3	2	5_8 LOCK WASHER	HELICAL LOCK WASHER	
4	2	5_8 - 11 HEX-NUT	HEX NUT	
5	4	7/16-14 x 1 1/2	CARRIAGE BOLT	
6	4	CM-SP2	.250 x .88 x 2.25" SQUARE HOLE SPACER	
7	4	CM-SP104	.125 x 1.00 SPACER	
8	4	7/16 LOCK WASHER	HELICAL LOCK WASHER	
9	4	7/16-14	HEX NUT	
10	2	CM-11150-SP	.25 x 2.50 SPACER PLATE	
11	1	CM-438-FW	7/16" FISHWIRE TOOL	

FISHWIRE TECHNIQUE

INSERT COILED END OF FISHWIRE TOOL THROUGH HITCH MOUNTING HOLE IN VEHICLE FRAME RAIL AND OUT THE ACCESS HOLE. PASS COILED END OF FISHWIRE THROUGH SPACER AND THREAD BOLT INTO COIL. KINK WIRE TO KEEP SPACER SEPERATE FROM BOLT AS SHOWN. PULL FISHWIRE, SPACER, AND BOLT THROUGH FRAME AND OUT MOUNTING HOLE. USE FISHWIRE TO GUIDE HITCH DURING MOUNTING AND PREVENT LOSS OF BOLT / SPACER INSIDE FRAME RAIL.

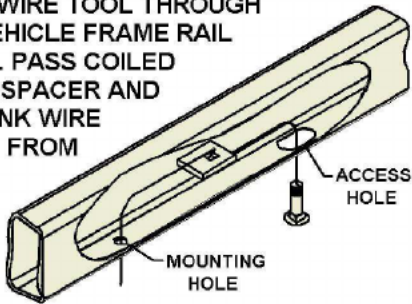

NOTE: SOME VEHICLES MAY FISHWIRE THROUGH END OF FRAME

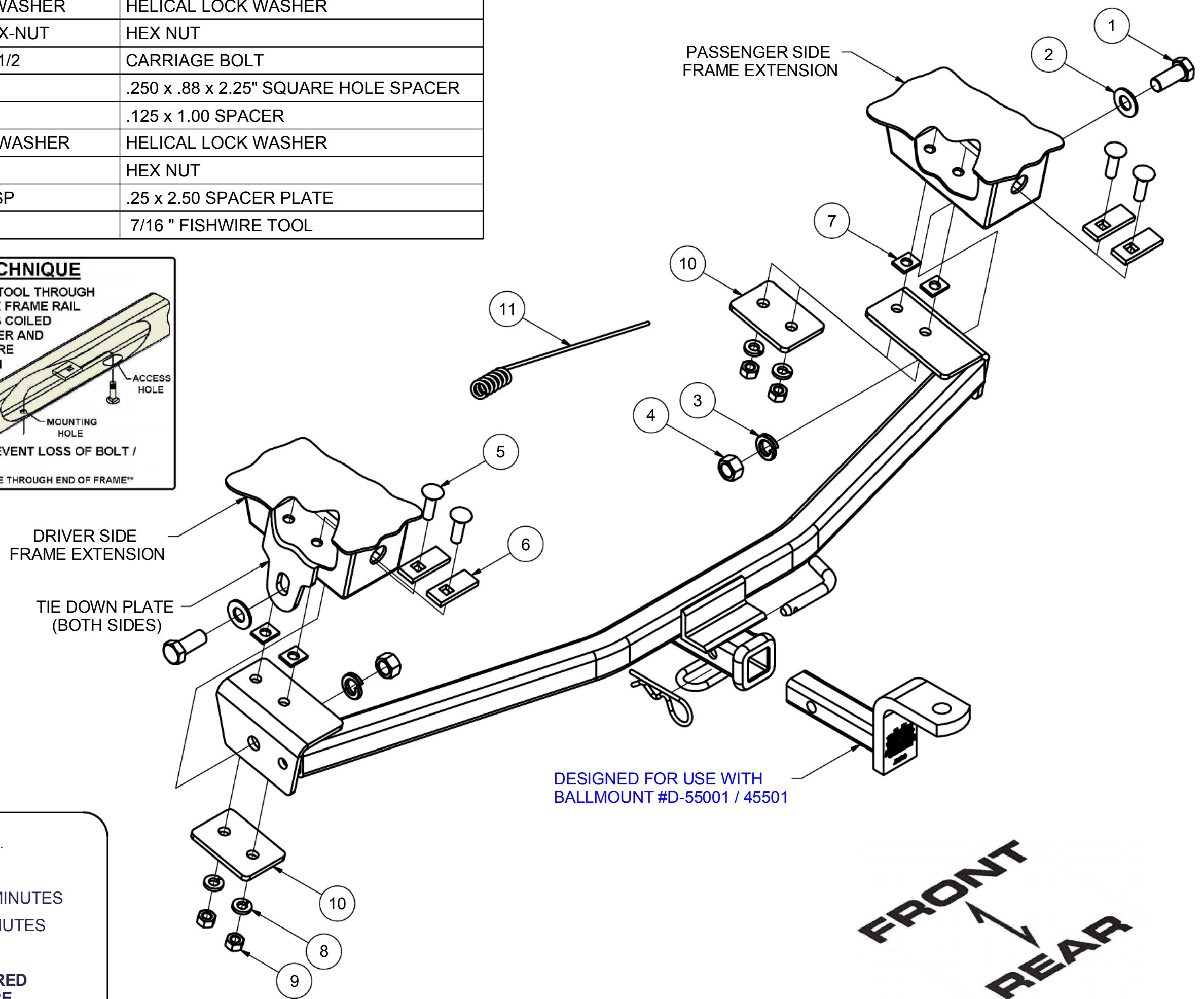

HITCH WEIGHT: 22 LBS.

INSTALL TIME

PROFESSIONAL: 45 MINUTES

NOVICE (DIY): 90 MINUTES

INSTALL NOTES:

- NO DRILLING REQUIRED
- FISHWIRE HARDWARE
- ENLARGE HOLES

INSTALLATION STEPS

1. Locate the vehicle frame extension (box member that projects down at the rear of the frame rail on each side with slotted tie down plates attached). Enlarge (2) existing holes in the bottom surface of the extension to 1/2" diameter.
2. Using the fishwire technique, pull (2) 7/16" carriage bolts with CM-SP2 spacers into each frame extension using access hole located as shown in diagram.
3. Carefully position the hitch between the vehicle tie down plates and up against the bottom of the frame extensions. On certain models with a lip, it may be necessary to use spacers provided as shown. Fasten the hitch using the remaining fasteners as shown.
4. Torque all 7/16" fasteners to 70 lb-ft, and all 5/8" fasteners to 210 lb-ft.

PERIODICALLY CHECK THIS RECEIVER HITCH TO ENSURE THAT ALL FASTENERS ARE TIGHT AND THAT ALL STRUCTURAL COMPONENTS ARE SOUND.

Curt Manufacturing Inc., warrants this product to be free of defects in material and/or workmanship at the time of retail purchase by the original purchaser. If the product is found to be defective, Curt Manufacturing Inc., may repair or replace the product, at their option, when the product is returned, prepaid, with proof of purchase. Alteration to, misuse of, or improper installation of this product voids the warranty. Curt Manufacturing Inc.'s liability is limited to repair or replacement of products found to be defective, and specifically excludes liability for incidental or consequential loss or damage.