

11148

96-00 HYUNDAI ELANTRA

9/23/2020

GROSS LOAD CAPACITY WHEN USED AS A WEIGHT CARRYING HITCH: 2,000 LBS. TRAILER WEIGHT &amp; 200 LBS. TONGUE WEIGHT.

**\*\*\*DO NOT EXCEED VEHICLE MANUFACTURER'S RECOMMENDED TOWING CAPACITY.\*\*\***

WARNING: ALL NON-TRAILER LOADS APPLIED TO THIS PRODUCT MUST BE SUPPORTED BY 18050 STABILIZING STRAPS.

**\*\* FAILURE TO PROPERLY SUPPORT NON-TRAILER LOADS WILL VOID PRODUCT WARRANTY\*\***

HAVING INSTALLATION QUESTIONS? CALL TECHNICAL SUPPORT AT 877-287-8634

Parts List			
ITEM	QTY	PART NUMBER	DESCRIPTION
1	2	CM-SP108	2.00 X 0.88 X .125 SPACER
2	1	10-10444	U-BOLT, 7/16-14 UNC, 1-1/2, N/A, CZ
3	2	20-00142	NUT, NYL LOCK, 7/16-14 UNC, GRD8, YZ
4	2	10-10282	BOLT, CAR, 7/16-14 UNC, 1-1/2, GRD8, YZ
5	2	30-00184	WASHER, LOCK, 7/16, YZ
6	2	20-00147	NUT, HEX, 7/16-14 UNC, GRD8, YZ
7	1	CM-11148-SP	.250" SPACER

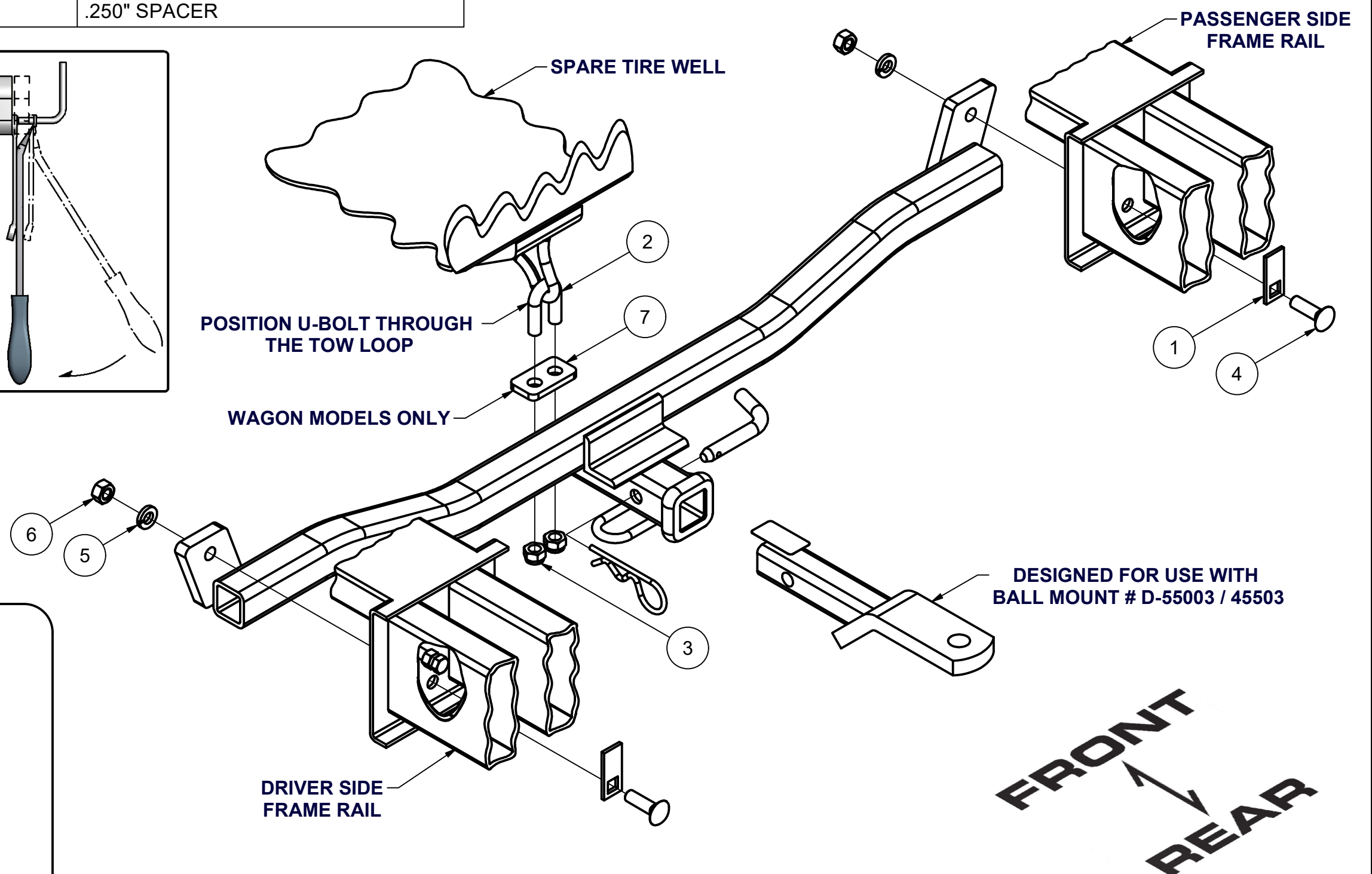
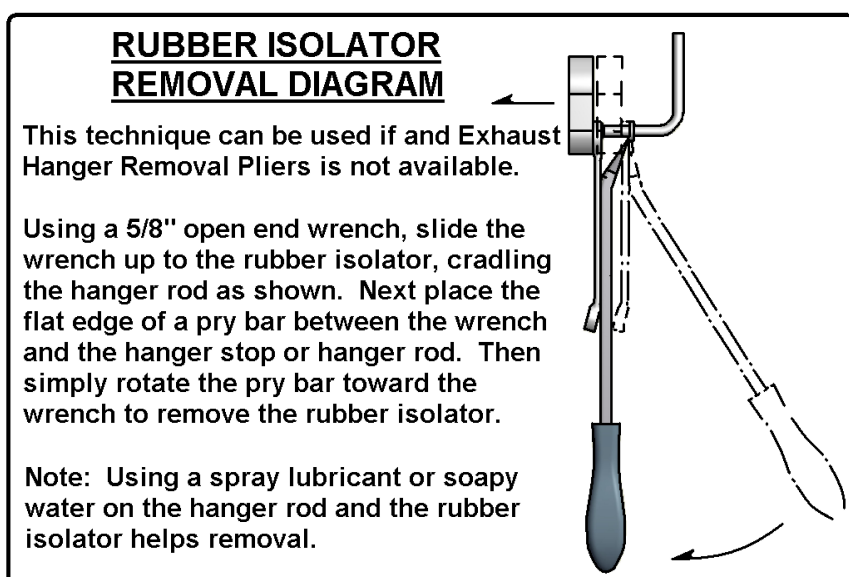

HITCH WEIGHT: 19 LBS.

INSTALL TIME

PROFESSIONAL: 60 MINUTES

NOVICE (DIY): 120 MINUTES

INSTALL NOTES:

- LOWER EXHAUST
- REMOVE BOLT
- DRILLING REQUIRED
- TRIM FASCIA

## INSTALLATION STEPS

1. This hitch mounts to the driver and passenger side vertical bumper supports and to the center tie-down loop as shown. Temporarily disconnect the rubber exhaust hanger to ease installation.
2. **SEDANS ONLY:** Remove the screw on center fascia tab and remove the metal bracket attached to the bumper beam. Trim fascia to remove the center tab. Trim the forward edge of driver and passenger fascia tabs as necessary.
3. Hold the hitch in position against the center tie-down loop as shown. Install U-bolt over the tie-down loop and secure with nylock nuts. Use the CM-11148-SP spacer at the tow loop on wagon models only.
4. Level the hitch, and using the hitch as a template, mark the hole locations for fasteners. Centerpunch and drill these holes for 7/16" fasteners.
5. Install fasteners as shown.
6. Torque all 7/16" carriage bolts to 59 ft-lbs. Torque 7/16" U-bolt to 25 ft-lbs.
7. Reinstall exhaust.

**PERIODICALLY CHECK THIS RECEIVER HITCH TO ENSURE THAT ALL FASTENERS ARE TIGHT AND THAT ALL STRUCTURAL COMPONENTS ARE SOUND.**

Curt Manufacturing Inc., warrants this product to be free of defects in material and/or workmanship at the time of retail purchase by the original purchaser. If the product is found to be defective, Curt Manufacturing Inc., may repair or replace the product, at their option, when the product is returned, prepaid, with proof of purchase. Alteration to, misuse of, or improper installation of this product voids the warranty. Curt Manufacturing Inc.'s liability is limited to repair or replacement of products found to be defective, and specifically excludes liability for incidental or consequential loss or damage.

247287