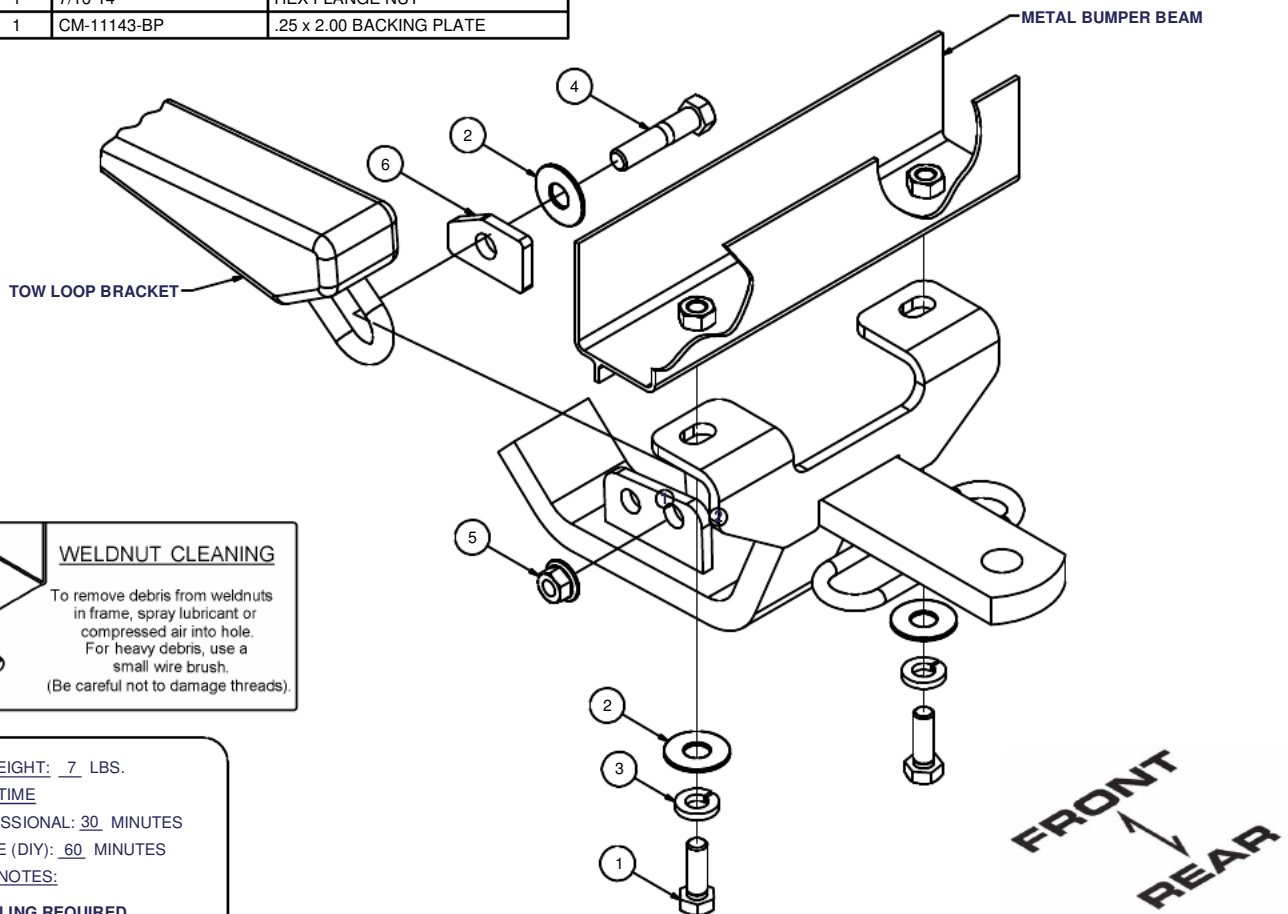

11143**90-91 ACURA INTEGRA HATCHBACK / 90-93 INTEGRA SEDAN****11/26/2012****GROSS LOAD CAPACITY WHEN USED AS A WEIGHT CARRYING HITCH: 2,000 LBS. TRAILER WEIGHT & 200 LBS. TONGUE WEIGHT.*******DO NOT EXCEED VEHICLE MANUFACTURER'S RECOMMENDED TOWING CAPACITY.*******WARNING: ALL NON-TRAILER LOADS APPLIED TO THIS PRODUCT MUST BE SUPPORTED BY AUXILIARY STABILIZING STRAPS.****** FAILURE TO PROPERLY SUPPORT NON-TRAILER LOADS WILL VOID PRODUCT WARRANTY******HAVING INSTALLATION QUESTIONS? CALL TECHNICAL SUPPORT AT 1-877-287-8634**

Parts List			
ITEM	QTY	PART NUMBER	DESCRIPTION
1	2	M10 - 1.25 x 30	HEX BOLT
2	3	7/16 WASHER	WASHER
3	2	7/16 LOCK WASHER	HELICAL LOCK WASHER
4	1	7/16-14 x 2.00"	HEX BOLT
5	1	7/16-14	HEX FLANGE NUT
6	1	CM-11143-BP	.25 x 2.00 BACKING PLATE

**HITCH WEIGHT: 7 LBS.****INSTALL TIME**PROFESSIONAL: 30 MINUTESNOVICE (DIY): 60 MINUTES**INSTALL NOTES:****-NO DRILLING REQUIRED****INSTALLATION STEPS**

1. Locate two existing 10mm threaded holes at the bottom of the rear bumper (metal beam inside the fascia). Notice the clearance holes in the bumper fascia near the license plate area.
2. Fasten the hitch to the car's bumper at these 10mm holes using fasteners as shown. Be certain to use the flat washers under the heads of the screws.
3. The loop bracket on the hitch locates to the driver's side of the car's tie down loop. Use the backing plate provided to sandwich the car's tie down loop. Use fasteners in position # 1 on four door cars, and position # 2 on 3 door models.
4. Torque all 7/16" fasteners to 70 lb-ft.

PERIODICALLY CHECK THIS RECEIVER HITCH TO ENSURE THAT ALL FASTENERS ARE TIGHT AND THAT ALL STRUCTURAL COMPONENTS ARE SOUND.

Curt Manufacturing Inc., warrants this product to be free of defects in material and/or workmanship at the time of retail purchase by the original purchaser. If the product is found to be defective, Curt Manufacturing Inc., may repair or replace the product, at their option, when the product is returned, prepaid, with proof of purchase. Alteration to, misuse of, or improper installation of this product voids the warranty. Curt Manufacturing Inc.'s liability is limited to repair or replacement of products found to be defective, and specifically excludes liability for incidental or consequential loss or damage.