

**YEARS:** 2011-CURRENT

**MAKE:** SUBARU

**MODEL:** IMPREZA WRX INCLUDING STI

**STYLE:** HATCHBACK

**WARNING: NEVER EXCEED YOUR VEHICLE MANUFACTURER'S RECOMMENDED TOWING CAPACITY**

**WEIGHT CARRYING:**  
**TRAILER WEIGHT:** 2,000 LBS.  
**TONGUE WEIGHT:** 200 LBS.

**WARNING:**  
 WE RECOMMEND THE USE OF 18050 STABILIZING STRAPS FOR ALL NON-TRAILER (WHEEL-LESS) LOADS. PLEASE SEE THE CURT CATALOG OR VISIT US ONLINE AT [WWW.CURTMFG.COM](http://WWW.CURTMFG.COM) FOR FURTHER INFORMATION.

**INSTALLATION TIME: 30 MIN.**

THE INSTALL TIME LISTED IS FOR PROFESSIONAL INSTALLERS. IF YOU ARE HESITANT TO UNDERTAKE THIS TASK ON YOUR OWN, CONTACT AN AUTHORIZED CURT INSTALLER FOR ADDITIONAL ASSISTANCE.

**INSTALLATION REQUIRES:**

		<b>10 mm 11/16"</b>
<b>PRY BAR</b>	<b>SCREW DRIVER</b>	<b>SOCKET</b>
<b>RATCHET</b>	<b>MARKER</b>	<b>UTILITY KNIFE</b>
<b>TORQUE WRENCH</b>	<b>TAPE MEASURE</b>	

**INSTALLATION TIPS:**

- BEFORE YOU BEGIN INSTALLATION, READ ALL INSTRUCTIONS THOROUGHLY.
- TO EASE INSTALLATION, 2 PEOPLE MAY BE REQUIRED.
- USING PROPER TOOLS WILL GREATLY IMPROVE THE QUALITY OF THE INSTALL AND REDUCE THE TIME REQUIRED.
- NEED HELP OR HAVE SOME QUESTIONS? CALL TECHNICAL SUPPORT AT 877.287.8634

**LEVEL OF DIFFICULTY: MODERATE**

EASY	MODERATE	HARD
	FASCIA TRIMMING REQUIRED	
	TEMPORARILY REMOVE (2) FASCIA BRACKETS	
	LOWER EXHAUST	
	FISHWIRE HARDWARE	
	REVERSE FISHWIRE HARDWARE	

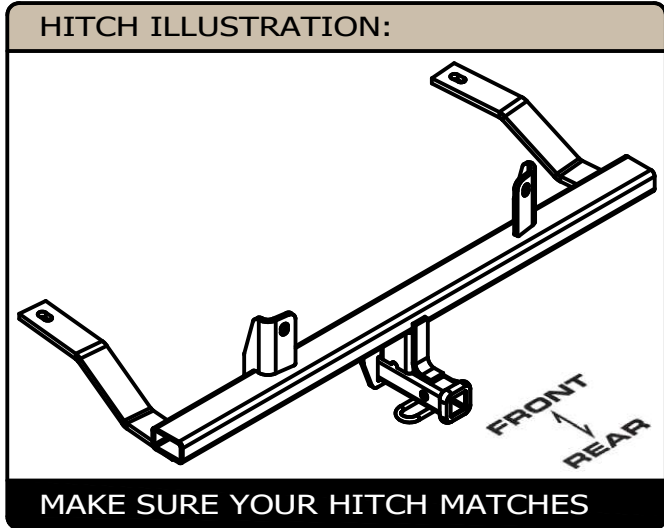

**PERIODICALLY CHECK THIS RECEIVER HITCH TO ENSURE ALL FASTENERS ARE TIGHT AND ALL STRUCTURAL COMPONENTS ARE SOUND**

CURT Manufacturing Inc. warrants this product to be free of defects in material and/or workmanship at the time of retail purchase by the original purchaser. If the product is found to be defective, Curt Manufacturing Inc. may repair or replace the product at their option, when the product is returned, prepaid, with proof of purchase. Alteration, misuse of, or improper installation of this product voids the warranty. Curt Manufacturing Inc.'s liability is limited to repair or replacement of products found to be defective, and specifically excludes liability for incidental or consequential loss or damage.

For more information log onto [www.curtmfg.com](http://www.curtmfg.com), & for helpful towing tips log onto [www.hitchinfo.com](http://www.hitchinfo.com)

# INSTALLATION WALKTHROUGH:

Parts List			
ITEM	QTY	PART NUMBER	DESCRIPTION
1	4	10-10282	BOLT, CAR, 7/16-14 UNC, 1-1/2, GRD8, YZ
2	4	20-00103	NUT, SER-FLANGE, 7/16-14 UNC, GRD8, YZ
3	4	CM-SP2	.250 x .88 x 2.25" SQUARE HOLE SPACER
4	4	7_16 FISHWIRE	7/16" FISHWIRE

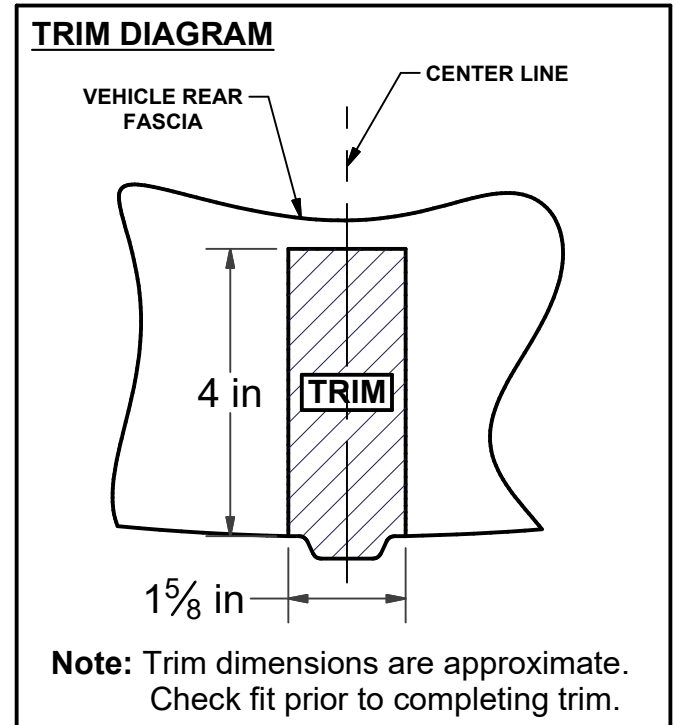
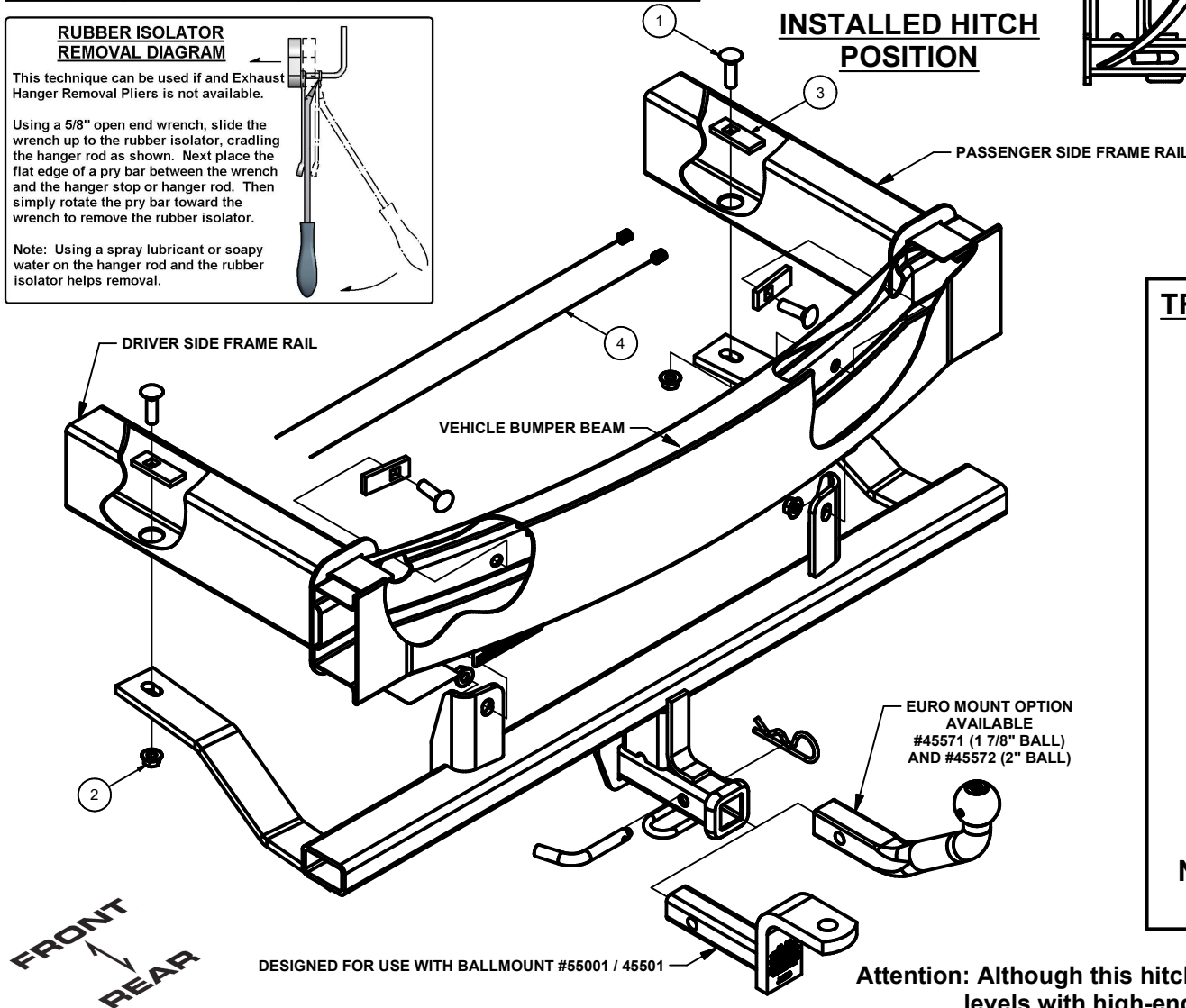
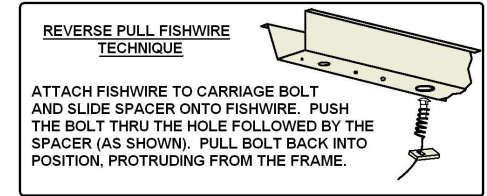
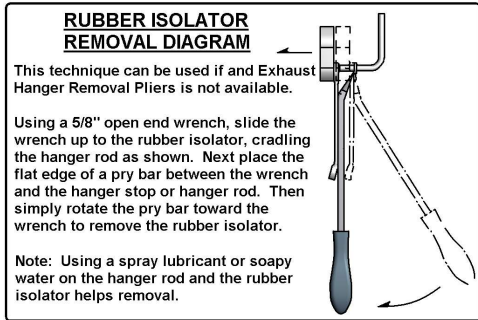
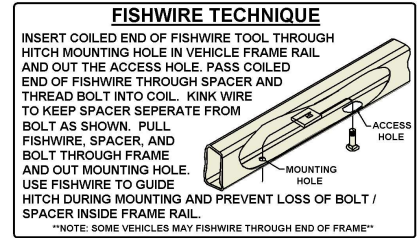
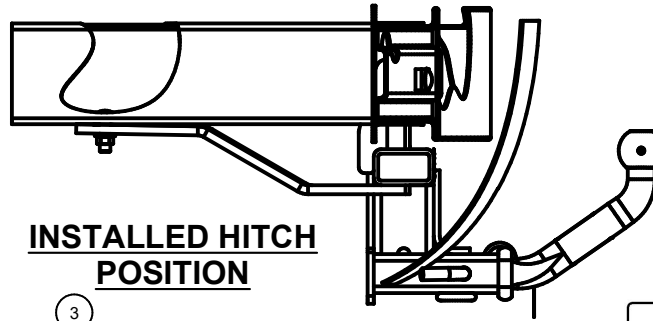

**Attention:** Although this hitch has been designed to fit this vehicle, some trim levels with high-end exhaust systems may not be compatible.

## INSTALLATION WALKTHROUGH:

1. Lower exhaust by removing (5) exhaust hangers. See RUBBER ISOLATOR REMOVAL DIAGRAM on page 2. (**Note:** Be sure to support exhaust to avoid possible damage.)

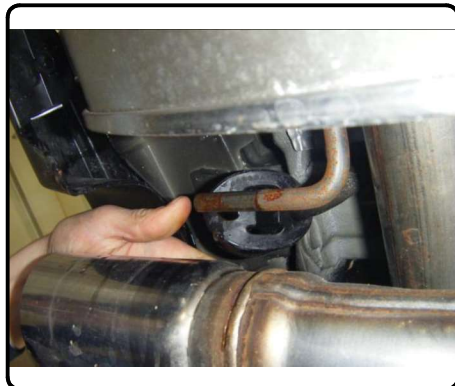

2. Remove (2) brackets which hold fascia to vehicle. These will be reinstalled in step 8.



3. Trim fascia. See TRIM DIAGRAM on page 2. (**Note:** Check fit prior to completing trim.)



4. Remove forward most rubber plug from each frame rail.

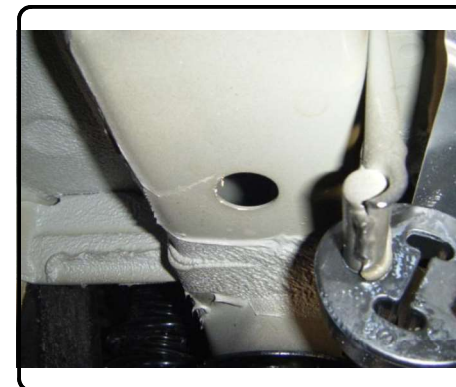



## INSTALLATION WALKTHROUGH:

5. Reverse fishwire 7/16" carriage bolt and CM-SP2 spacer into position in each frame rail. See REVERSE PULL FISHWIRE TECHNIQUE on page 2.



6. Fishwire (2) 7/16" carriage bolts and (2) CM-SP2 spacers into position in bumper beam through access holes. See FISHWIRE TECHNIQUE on page 2. (**Note:** Leave fishwires attached to hardware to prevent loss in beam.)



7. Thread fishwires through appropriate mounting holes on hitch and raise hitch into position.



8. Torque all 7/16" hardware to 70 ft-lbs. Reinstall (2) brackets which were removed in step 2.



GROSS LOAD CAPACITY WHEN USED AS A WEIGHT CARRYING HITCH: 2,000 LBS. TRAILER WEIGHT & 200 LBS. TONGUE WEIGHT.

\*\*\*DO NOT EXCEED VEHICLE MANUFACTURER'S RECOMMENDED TOWING CAPACITY.\*\*\*

WARNING: ALL NON-TRAILER LOADS APPLIED TO THIS PRODUCT MUST BE SUPPORTED BY 18050 STABILIZING STRAPS.

\*\* FAILURE TO PROPERLY SUPPORT NON-TRAILER LOADS WILL VOID PRODUCT WARRANTY\*\*

HAVING INSTALLATION QUESTIONS? CALL TECHNICAL SUPPORT AT 1-877-287-8634

Parts List			
ITEM	QTY	PART NUMBER	DESCRIPTION
1	4	10-10282	BOLT,CAR,7/16-14 UNC,1-1/2,GRD8,YZ
2	4	20-00103	NUT,SER-FLANGE,7/16-14 UNC,GRD8,YZ
3	4	CM-SP2	.250 x .88 x 2.25" SQUARE HOLE SPACER
4	4	7_16 FISHWIRE	7/16" FISHWIRE

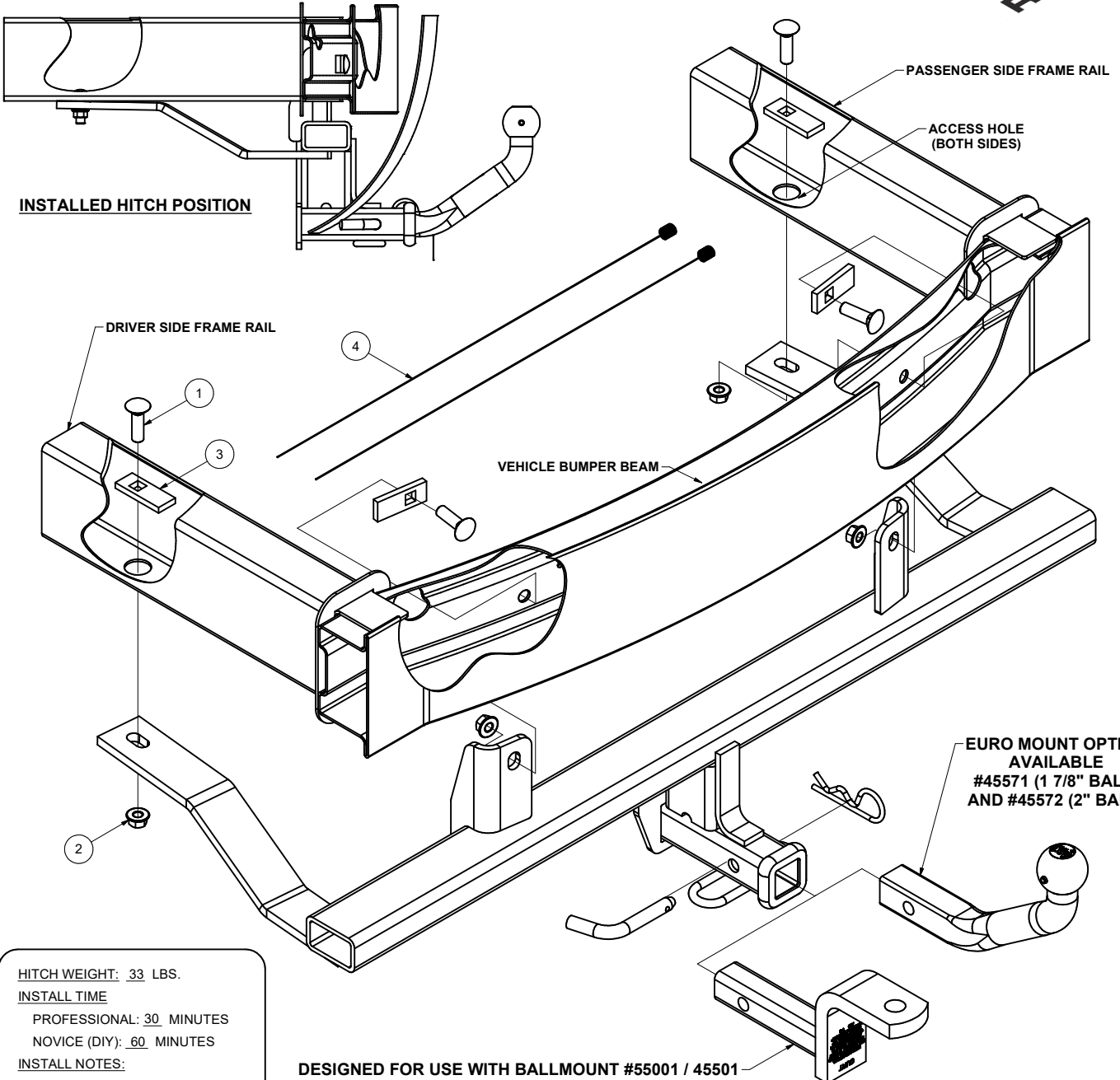

HITCH WEIGHT: 33 LBS.  
 INSTALL TIME  
 PROFESSIONAL: 30 MINUTES  
 NOVICE (DIY): 60 MINUTES  
 INSTALL NOTES:  
 -FASCIA TRIMMING REQUIRED  
 -LOWER EXHAUST  
 -FISHWIRE HARDWARE

DESIGNED FOR USE WITH BALLMOUNT #55001 / 45501

**PERIODICALLY CHECK THIS RECEIVER HITCH TO ENSURE THAT ALL FASTENERS ARE TIGHT AND THAT ALL STRUCTURAL COMPONENTS ARE SOUND.**

Curt Manufacturing Inc., warrants this product to be free of defects in material and/or workmanship at the time of retail purchase by the original purchaser. If the product is found to be defective, Curt Manufacturing Inc., may repair or replace the product, at their option, when the product is returned, prepaid, with proof of purchase. Alteration to, misuse of, or improper installation of this product voids the warranty. Curt Manufacturing Inc.'s liability is limited to repair or replacement of products found to be defective, and specifically excludes liability for incidental or consequential loss or damage.

HAVING INSTALLATION QUESTIONS? CALL TECHNICAL SUPPORT AT 1-877-287-8634

#### TOOLS REQUIRED

PRY BAR
SCREWDRIVER
10mm & 11/16" SOCKET
RATCHET
MARKER
UTILITY KNIFE
TORQUE WRENCH

### TRIM DIAGRAM

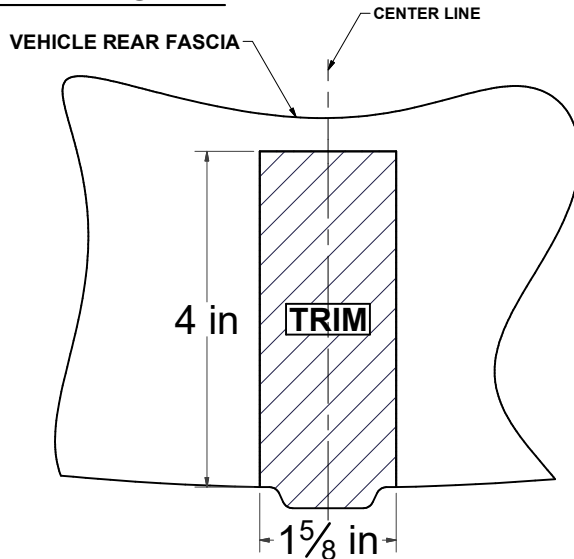

**Note:** Trim dimensions are approximate. Check fit prior to completing trim.

#### REVERSE PULL FISHWIRE TECHNIQUE

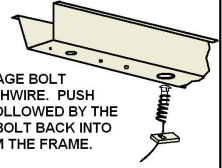

ATTACH FISHWIRE TO CARRIAGE BOLT AND SLIDE SPACER ONTO FISHWIRE. PUSH THE BOLT THRU THE HOLE FOLLOWED BY THE SPACER (AS SHOWN). PULL BOLT BACK INTO POSITION, PROTRUDING FROM THE FRAME.

#### RUBBER ISOLATOR REMOVAL DIAGRAM

This technique can be used if and Exhaust Hanger Removal Pliers is not available.

Using a 5/8" open end wrench, slide the wrench up to the rubber isolator, cradling the hanger rod as shown. Next place the flat edge of a pry bar between the wrench and the hanger stop or hanger rod. Then simply rotate the pry bar toward the wrench to remove the rubber isolator.

**Note:** Using a spray lubricant or soapy water on the hanger rod and the rubber isolator helps removal.

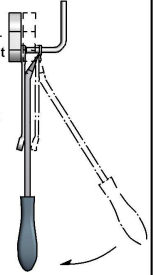

#### FISHWIRE TECHNIQUE

INSERT COILED END OF FISHWIRE TOOL THROUGH HITCH MOUNTING HOLE IN VEHICLE FRAME RAIL AND OUT THE ACCESS HOLE. PASS COILED END OF FISHWIRE THROUGH SPACER AND THREAD BOLT INTO COIL. KINK WIRE TO KEEP SPACER SEPARATE FROM BOLT AS SHOWN. PULL FISHWIRE, SPACER, AND BOLT THROUGH FRAME AND OUT MOUNTING HOLE. USE FISHWIRE TO GUIDE HITCH DURING MOUNTING AND PREVENT LOSS OF BOLT / SPACER INSIDE FRAME RAIL.

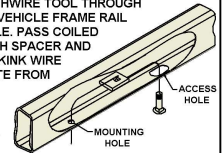

**\*NOTE: SOME VEHICLES MAY FISHWIRE THROUGH END OF FRAME\*\***

## INSTALLATION STEPS

Attention: Although this hitch has been designed to fit this vehicle, some trim levels with high-end exhaust systems may not be compatible.

1. Lower exhaust by removing (5) exhaust hangers. See RUBBER ISOLATOR REMOVAL DIAGRAM above. (**Note:** Be sure to support exhaust to avoid possible damage.)
2. Remove (2) brackets which hold fascia to vehicle. These will be reinstalled in step 9.
3. Trim fascia. See TRIM DIAGRAM above. (**Note:** Check fit prior to completing trim.)
4. Remove forward most rubber plug from each frame rail.
5. Reverse fishwire 7/16" carriage bolt and CM-SP2 spacer into position in each frame rail. See REVERSE PULL FISHWIRE TECHNIQUE above.
6. Fishwire (2) 7/16" carriage bolts and (2) CM-SP2 spacers into position in bumper beam through access holes. See FISHWIRE TECHNIQUE above. (**Note:** Leave fishwires attached to hardware to prevent loss in beam.)
7. Thread fishwires through appropriate mounting holes on hitch and raise hitch into position.
8. Torque all 7/16" hardware to 70 ft-lbs.
9. Reinstall (2) brackets which were removed in step 2.

**PERIODICALLY CHECK THIS RECEIVER HITCH TO ENSURE THAT ALL FASTENERS ARE TIGHT AND THAT ALL STRUCTURAL COMPONENTS ARE SOUND.**