

11113

95-00 FORD CONTOUR, MERCURY MYSTIQUE

10/12/2012

EXCLUDING SVT MODELS

GROSS LOAD CAPACITY WHEN USED AS A WEIGHT CARRYING HITCH: 2,000 LBS. TRAILER WEIGHT & 200 LBS. TONGUE WEIGHT.

*****DO NOT EXCEED VEHICLE MANUFACTURER'S RECOMMENDED TOWING CAPACITY.*****

WARNING: ALL NON-TRAILER LOADS APPLIED TO THIS PRODUCT MUST BE SUPPORTED BY AUXILIARY STABILIZING STRAPS.

**** FAILURE TO PROPERLY SUPPORT NON-TRAILER LOADS WILL VOID PRODUCT WARRANTY****

HAVING INSTALLATION QUESTIONS? CALL TECHNICAL SUPPORT AT 1-800-798-0813

Parts List			
ITEM	QTY	PART NUMBER	DESCRIPTION
1	2	1/2-13	HANDLE NUT
2	2	1/2"	LOCK WASHER
3	4	M8-1.25	HEX FLANGE NUT
4	2	1/2-13 x 1 1/4	HEX BOLT

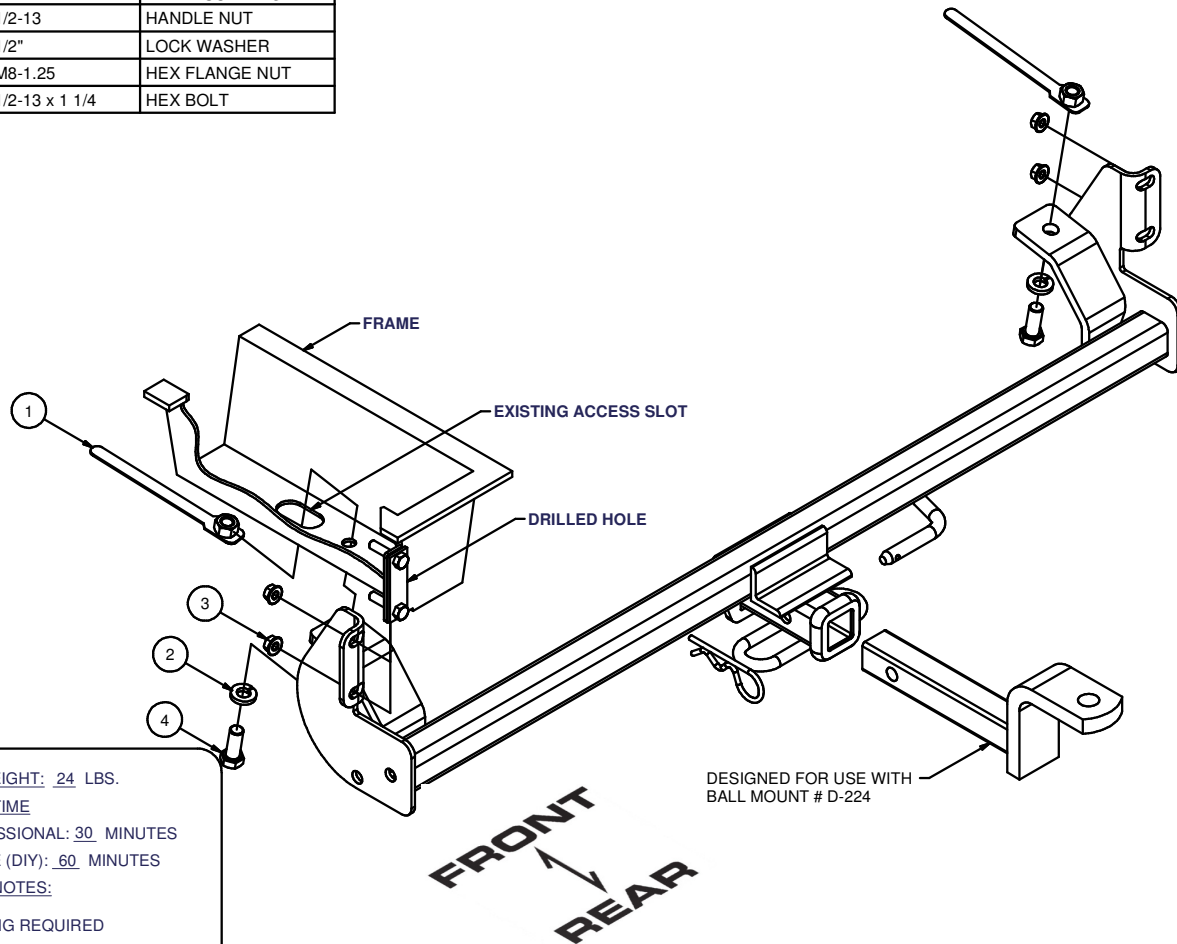

HITCH WEIGHT: 24 LBS.

INSTALL TIME

PROFESSIONAL: 30 MINUTES

NOVICE (DIY): 60 MINUTES

INSTALL NOTES:

DRILLING REQUIRED

INSTALLATION STEPS

- 1) Remove and discard existing M8 nuts that attach the bumper to the frame, each side.
- 2) Raise hitch into position over the existing M8 bolt straps.
- 3) Fasten with hex flange nut each side.
- 4) Using the hitch as a template, drill 1/2" hole through hitch and into frame each side.
- 5) Enlarge existing access slot as necessary to insert handle nut each side.
- 6) Insert handle nut through enlarged slot in bottom of frame and over drilled hole each side.
- 7) Install remaining 1/2" lock washer and bolt up through hitch and into frame and handle nut each side.
- 8) Torque M8 fasteners to 23 lb.-ft. Torque 1/2" fasteners to 110 lb.-ft.

PERIODICALLY CHECK THIS RECEIVER HITCH TO ENSURE THAT ALL FASTENERS ARE TIGHT AND THAT ALL STRUCTURAL COMPONENTS ARE SOUND.

Curt Manufacturing Inc., warrants this product to be free of defects in material and/or workmanship at the time of retail purchase by the original purchaser. If the product is found to be defective, Curt Manufacturing Inc., may repair or replace the product, at their option, when the product is returned, prepaid, with proof of purchase. Alteration to, misuse of, or improper installation of this product voids the warranty. Curt Manufacturing Inc.'s liability is limited to repair or replacement of products found to be defective, and specifically excludes liability for incidental or consequential loss or damage.