

11096 VOLKSWAGEN PASSAT WAGON (EXCEPT 4 MOTION)

10/12/2012

GROSS LOAD CAPACITY WHEN USED AS A WEIGHT CARRYING HITCH: 2,000 LBS. TRAILER WEIGHT & 200 LBS. TONGUE WEIGHT.

*****DO NOT EXCEED VEHICLE MANUFACTURER'S RECOMMENDED TOWING CAPACITY.*****

WARNING: ALL NON-TRAILER LOADS APPLIED TO THIS PRODUCT MUST BE SUPPORTED BY AUXILIARY STABILIZING STRAPS.

**** FAILURE TO PROPERLY SUPPORT NON-TRAILER LOADS WILL VOID PRODUCT WARRANTY****

HAVING INSTALLATION QUESTIONS? CALL TECHNICAL SUPPORT AT 1-800-798-0813

Parts List			
ITEM	QTY	PART NUMBER	DESCRIPTION
1	2	CM-SP2	.250 x .88 x 2.25" SQUARE HOLE SPACER
2	2	7/16 - 14 x 1 3/4	CARRIAGE BOLT
3	2	5/16"	WASHER
4	2	M8-1.25 x 40	HEX BOLT
5	2	7/16-14	HEX FLANGE NUT
6	1	CM-438-FW	7/16" FISHWIRE TOOL

FISHWIRE TECHNIQUE

INSERT COILED END OF FISHWIRE TOOL THROUGH HITCH MOUNTING HOLE IN VEHICLE FRAME RAIL AND OUT THE ACCESS HOLE. PASS COILED END OF FISHWIRE THROUGH SPACER AND THREAD BOLT INTO COIL. KINK WIRE TO KEEP SPACER SEPARATE FROM BOLT AS SHOWN. PULL FISHWIRE, SPACER, AND BOLT THROUGH FRAME AND OUT MOUNTING HOLE. USE FISHWIRE TO GUIDE HITCH DURING MOUNTING AND PREVENT LOSS OF BOLT / SPACER INSIDE FRAME RAIL.

NOTE: SOME VEHICLES MAY FISHWIRE THROUGH END OF FRAME

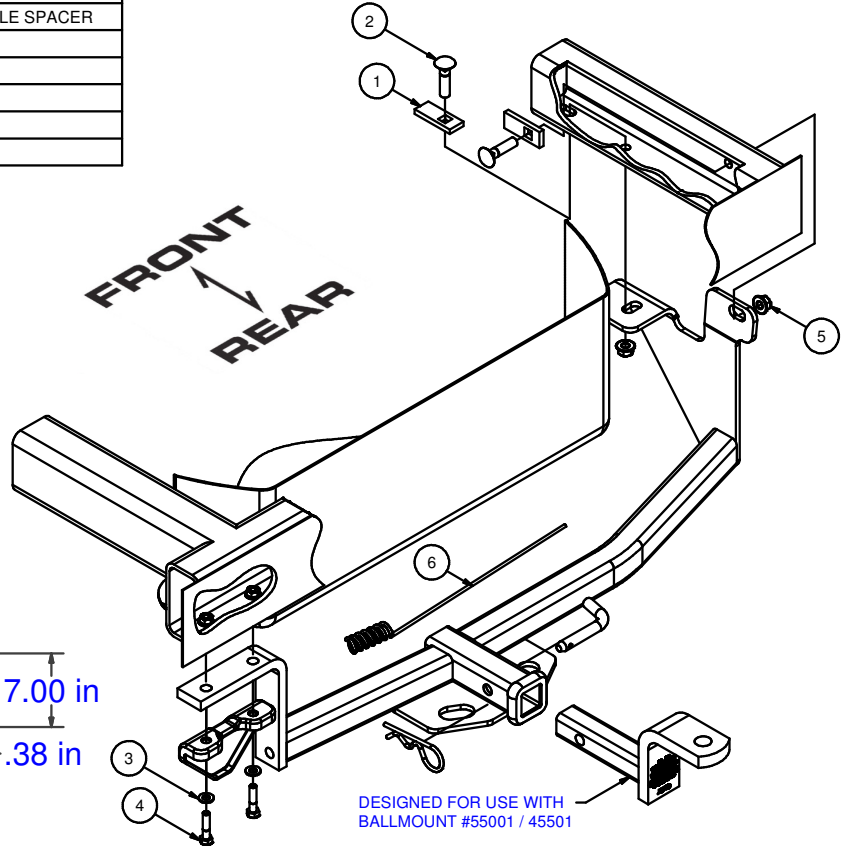

DESIGNED FOR USE WITH BALLMOUNT #55001 / 45501

REAR BUMPER FASCIA TRIM DIAGRAM

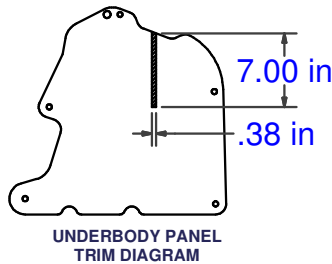
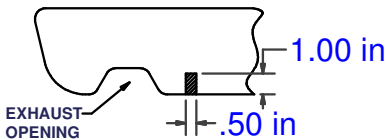

HITCH WEIGHT: 23 LBS.

INSTALL TIME

PROFESSIONAL: 45 MINUTES

NOVICE (DIY): 90 MINUTES

INSTALL NOTES:

- DRILLING REQUIRED
- LOWER UNDERBODY PANEL
- FASCIA TRIMMING REQUIRED
- LOWER EXHAUST

INSTALLATION STEPS

- 1) Lower underbody panel by removing (5) torx head screws. (Trim panel and reuse later).
- 2) Lower exhaust by removing (2) screws from exhaust hanger.
- 3) Fishwire 7/16" carriage bolt and spacer through access hole and out rear most hole in passenger side frame as shown.
- 4) Raise hitch into position over exhaust and secure driver side with (2) hex bolts into the existing weldnuts.
- 5) Using hitch as a template, drill required hole into frame rail for remaining fastener. Fishwire 7/16" carriage bolt and spacer through access hole and into drilled hole as shown. Secure with 7/16" flange nut.
- 6) Torque all M8 bolts to 23 lb-ft and all 7/16" fasteners to 70 lb-ft.
- 7) Replace exhaust hanger removed in step 2.
- 8) Trim rear bumper fascia and underbody panel as shown in illustrations above. Reinstall underbody panel using torx head screws removed in step 1.

PERIODICALLY CHECK THIS RECEIVER HITCH TO ENSURE THAT ALL FASTENERS ARE TIGHT AND THAT ALL STRUCTURAL COMPONENTS ARE SOUND.

Curt Manufacturing Inc., warrants this product to be free of defects in material and/or workmanship at the time of retail purchase by the original purchaser. If the product is found to be defective, Curt Manufacturing Inc., may repair or replace the product, at their option, when the product is returned, prepaid, with proof of purchase. Alteration to, misuse of, or improper installation of this product voids the warranty. Curt Manufacturing Inc.'s liability is limited to repair or replacement of products found to be defective, and specifically excludes liability for incidental or consequential loss or damage.