



# 11061 INSTALLATION INSTRUCTIONS



Safety glasses should be worn at all times while installing this product.

YEARS: 2011

MAKE: FORD

MODEL: MUSTANG 5.0L GT

STYLE: CONVERTIBLE ONLY

**WARNING: NEVER EXCEED YOUR VEHICLE MANUFACTURER'S RECOMMENDED TOWING CAPACITY**





**WEIGHT CARRYING:**  
TRAILER WEIGHT: 2,000 LBS.  
TONGUE WEIGHT: 200 LBS.

**WARNING:**  
WE RECOMMEND THE USE OF 18050 STABILIZING STRAPS FOR ALL NON-TRAILER (WHEEL-LESS) LOADS. PLEASE SEE THE CURT CATALOG OR VISIT US ONLINE AT [WWW.CURTMFG.COM](http://WWW.CURTMFG.COM) FOR FURTHER INFORMATION.

**INSTALLATION TIME: 40 MIN.**

THE INSTALL TIME LISTED IS FOR PROFESSIONAL INSTALLERS. IF YOU ARE HESITANT TO UNDERTAKE THIS TASK ON YOUR OWN, CONTACT AN AUTHORIZED CURT INSTALLER FOR ADDITIONAL ASSISTANCE.



### INSTALLATION REQUIRES:

 <b>PRY BAR</b>	 <b>RATCHET</b>	 <b>3/4" 11/16" 13mm SOCKET</b>
 <b>TORQUE WRENCH</b>		

### INSTALLATION TIPS:

- BEFORE YOU BEGIN INSTALLATION, READ ALL INSTRUCTIONS THOROUGHLY.
- TO EASE INSTALLATION, 2 PEOPLE MAY BE REQUIRED.
- USING PROPER TOOLS WILL GREATLY IMPROVE THE QUALITY OF THE INSTALL AND REDUCE THE TIME REQUIRED.
- NEED HELP OR HAVE SOME QUESTIONS? CALL TECHNICAL SUPPORT AT 877.287.8634

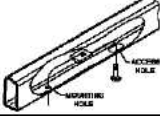
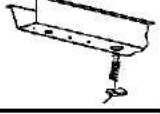
### LEVEL OF DIFFICULTY: MODERATE

EASY	MODERATE	HARD
	REMOVE (2) RUBBER ISOLATORS AND DETACH EXHAUST PIPES	
	FISHWIRE HARDWARE	
	REVERSE FISHWIRE HARDWARE	
	NO DRILLING REQUIRED	

### VEHICLE PHOTO:



REPRESENTATIVE PHOTO

### HITCH ILLUSTRATION:

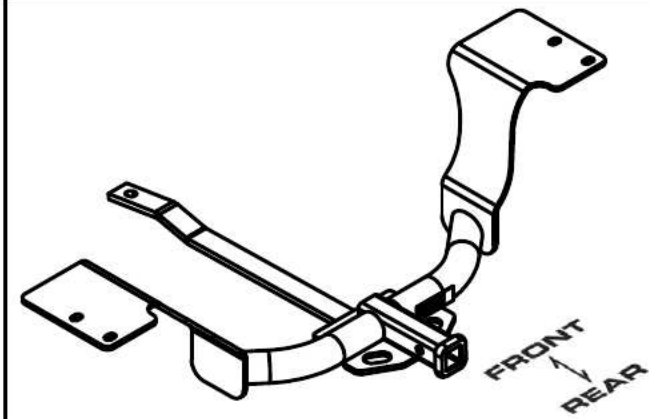

MAKE SURE YOUR HITCH MATCHES

**PERIODICALLY CHECK THIS RECEIVER HITCH TO ENSURE ALL FASTENERS ARE TIGHT AND ALL STRUCTURAL COMPONENTS ARE SOUND**

CURT Manufacturing Inc. warrants this product to be free of defects in material and/or workmanship at the time of retail purchase by the original purchaser. If the product is found to be defective, Curt Manufacturing Inc. may repair or replace the product at their option, when the product is returned, prepaid, with proof of purchase. Alteration to, misuse of, or improper installation of this product voids the warranty. Curt Manufacturing Inc.'s liability is limited to repair or replacement of products found to be defective, and specifically excludes liability for incidental or consequential loss or damage.

# INSTALLATION WALKTHROUGH:

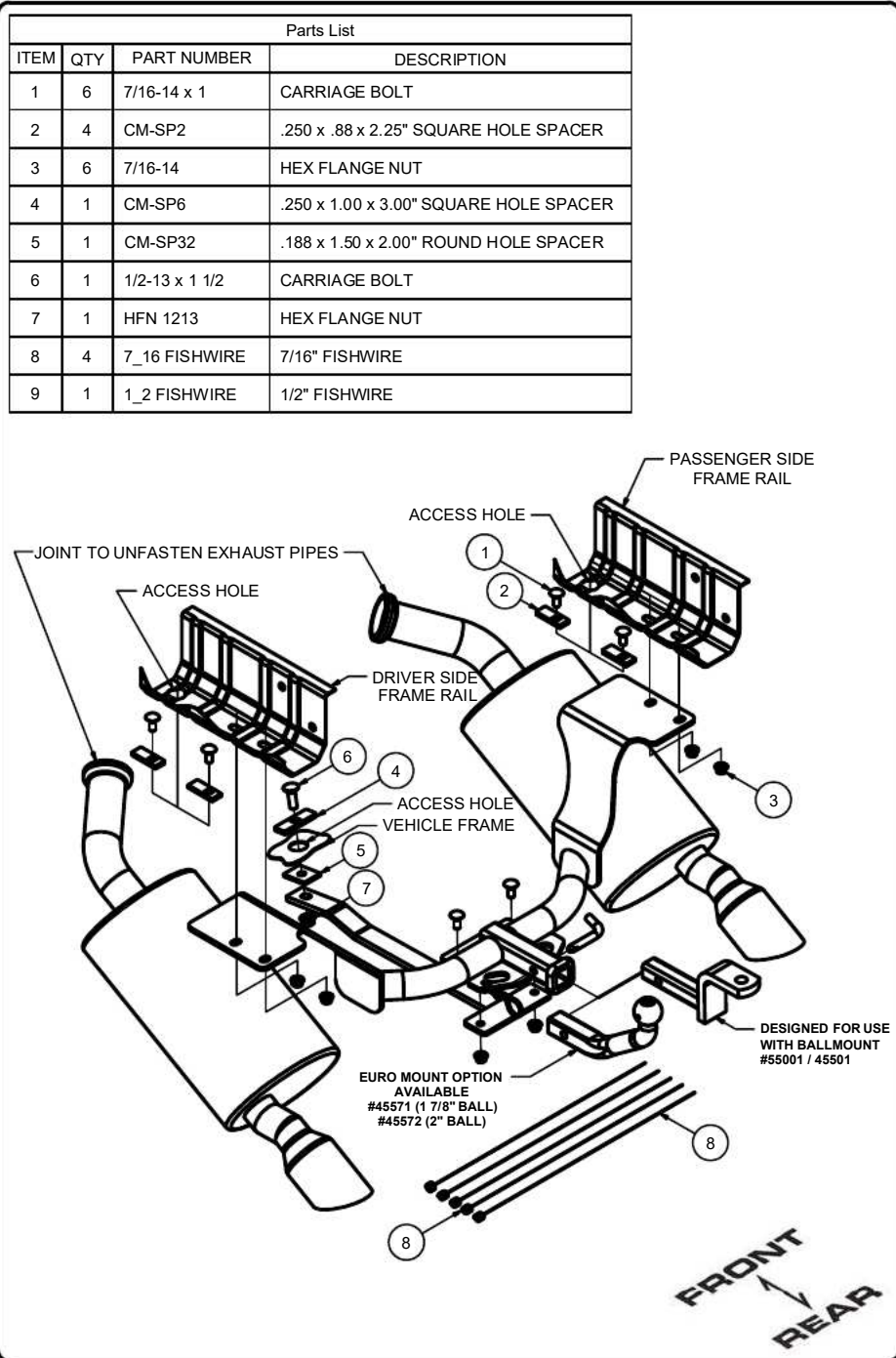

1. Remove the rearmost rubber isolator on both mufflers.



2. Lower exhaust by loosening the strap which fastens the exhaust pipes together behind the muffler and detach the pipes from each other. Carefully lower the rear of the muffler and let it hang from the remaining exhaust hanger. Repeat on other side.



## INSTALLATION WALKTHROUGH:

3. Fishwire (4) 7/16 x 1" carriage bolts and (4) SP2 spacers into place through the access holes, as shown. (See FISHWIRE TECHNIQUE) Leave fishwires attached to prevent pushing hardware into frame rails during hitch installation.

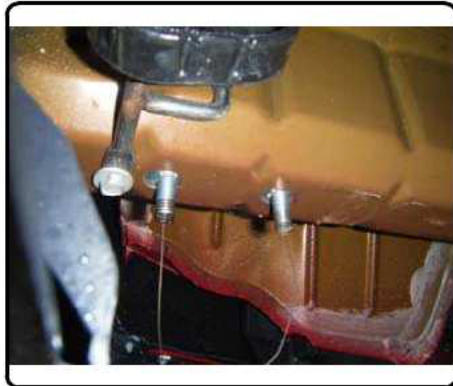

4. Raise hitch into position and secure hitch with (4) 7/16" flange nuts.



5. Reverse fishwire (1) SP-6 spacer and (1) 1/2 x 1 1/2" carriage bolt into position in mounting hole. Place (1) SP32 spacer on the 1/2" carriage bolt then raise the mounting strap into position and secure with (1) 1/2" flange nut. Secure mounting strap to hitch using (2) 7/16 x 1" carriage bolts and (2) 7/16" flange nuts.



6. Torque all 10mm hardware to 35 ft-lbs, 7/16" hardware to 50 ft/lbs and all 1/2" hardware to 75 ft/lbs. Re-install exhaust. Install is complete.

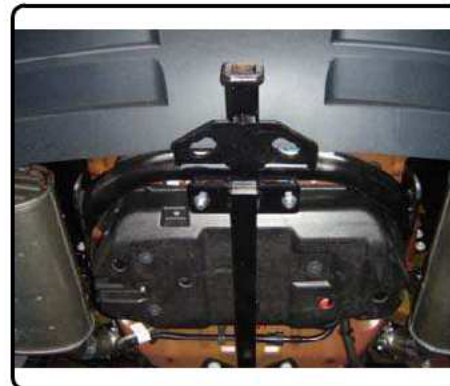

**11061****FORD MUSTANG 5.0L GT (CONVERTIBLE ONLY)**

1/4/2011

GROSS LOAD CAPACITY WHEN USED AS A WEIGHT CARRYING HITCH: 2,000 LBS. TRAILER WEIGHT &amp; 200 LBS. TONGUE WEIGHT.

**\*\*\*DO NOT EXCEED VEHICLE MANUFACTURER'S RECOMMENDED TOWING CAPACITY.\*\*\***

WARNING: ALL NON-TRAILER LOADS APPLIED TO THIS PRODUCT MUST BE SUPPORTED BY 18050 STABILIZING STRAPS.

**\*\* FAILURE TO PROPERLY SUPPORT NON-TRAILER LOADS WILL VOID PRODUCT WARRANTY\*\***

HAVING INSTALLATION QUESTIONS? CALL TECHNICAL SUPPORT AT 1-877-287-8634

Parts List			
ITEM	QTY	PART NUMBER	DESCRIPTION
1	6	7/16-14 x 1	CARRIAGE BOLT
2	4	CM-SP2	.250 x .88 x 2.25" SQUARE HOLE SPACER
3	6	7/16-14	HEX FLANGE NUT
4	1	CM-SP6	.250 x 1.00 x 3.00" SQUARE HOLE SPACER
5	1	CM-SP32	.188 x 1.50 x 2.00" ROUND HOLE SPACER
6	1	HFN 1213	HEX FLANGE NUT
7	1	1/2-13 x 1 1/2	CARRIAGE BOLT
8	4	7_16 FISHWIRE	7/16" FISHWIRE
9	1	1_2 FISHWIRE	1/2" FISHWIRE

TOOLS REQUIRED
PRY BAR
RATCHET
3/4", 11/16", 13mm SOCKETS
TORQUE WRENCH

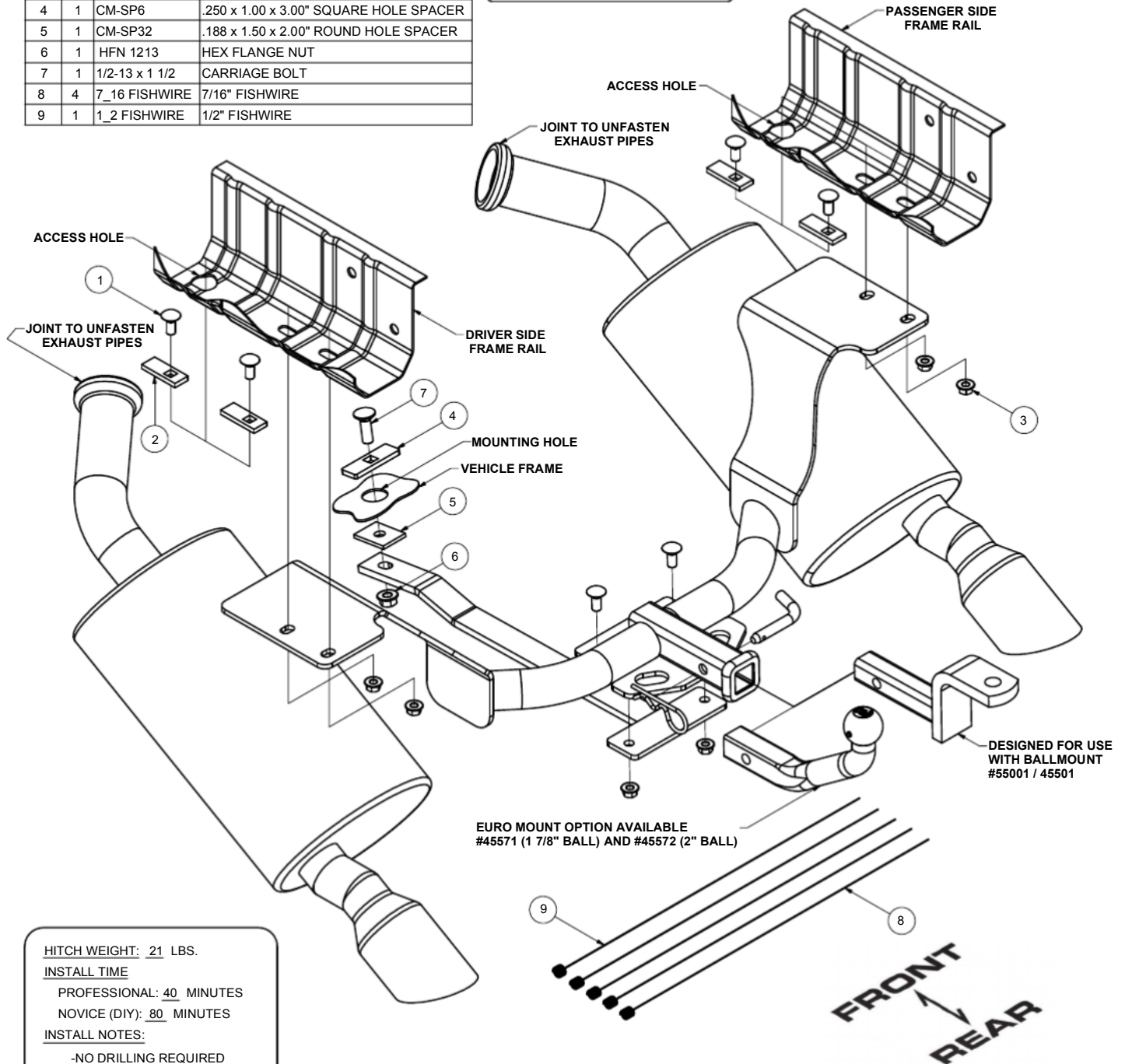

HITCH WEIGHT: 21 LBS.

INSTALL TIME

PROFESSIONAL: 40 MINUTES

NOVICE (DIY): 80 MINUTES

INSTALL NOTES:

- NO DRILLING REQUIRED
- FISHWIRE HARDWARE
- LOWER EXHAUST

**PERIODICALLY CHECK THIS RECEIVER HITCH TO ENSURE THAT ALL FASTENERS ARE TIGHT AND THAT ALL STRUCTURAL COMPONENTS ARE SOUND.**

Curt Manufacturing Inc., warrants this product to be free of defects in material and/or workmanship at the time of retail purchase by the original purchaser. If the product is found to be defective, Curt Manufacturing Inc., may repair or replace the product, at their option, when the product is returned, prepaid, with proof of purchase. Alteration to, misuse of, or improper installation of this product voids the warranty. Curt Manufacturing Inc.'s liability is limited to repair or replacement of products found to be defective, and specifically excludes liability for incidental or consequential loss or damage.

**11061****FORD MUSTANG 5.0L GT (CONVERTIBLE ONLY)**

1/4/2011

HAVING INSTALLATION QUESTIONS? CALL TECHNICAL SUPPORT AT 1-877-287-8634

**RUBBER ISOLATOR  
REMOVAL DIAGRAM**

This technique can be used if and Exhaust Hanger Removal Pliers is not available.

Using a 5/8" open end wrench, slide the wrench up to the rubber isolator, cradling the hanger rod as shown. Next place the flat edge of a pry bar between the wrench and the hanger stop or hanger rod. Then simply rotate the pry bar toward the wrench to remove the rubber isolator.

Note: Using a spray lubricant or soapy water on the hanger rod and the rubber isolator helps removal.

**FISHWIRE TECHNIQUE**

INSERT COILED END OF FISHWIRE TOOL THROUGH HITCH MOUNTING HOLE IN VEHICLE FRAME RAIL AND OUT THE ACCESS HOLE. PASS COILED END OF FISHWIRE THROUGH SPACER AND THREAD BOLT INTO COIL. KINK WIRE TO KEEP SPACER SEPARATE FROM BOLT AS SHOWN. PULL FISHWIRE, SPACER, AND BOLT THROUGH FRAME AND OUT MOUNTING HOLE. USE FISHWIRE TO GUIDE HITCH DURING MOUNTING AND PREVENT LOSS OF BOLT / SPACER INSIDE FRAME RAIL.

\*\*NOTE: SOME VEHICLES MAY FISHWIRE THROUGH END OF FRAME\*\*

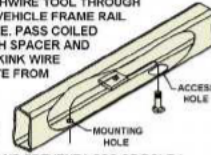
**REVERSE PULL FISHWIRE  
TECHNIQUE**

ATTACH FISHWIRE TO CARRIAGE BOLT AND SLIDE SPACER ONTO FISHWIRE. PUSH THE BOLT THRU THE HOLE FOLLOWED BY THE SPACER (AS SHOWN). PULL BOLT BACK INTO POSITION, PROTRUDING FROM THE FRAME.

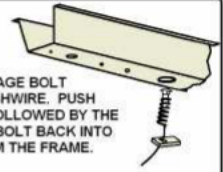

DETACH EXHAUST PIPES 1A

DETACH EXHAUST PIPES 1B

**INSTALLATION STEPS**

1. Remove the rearmost rubber isolator on both mufflers. (See RUBBER ISOLATOR REMOVAL DIAGRAM)
2. Lower exhaust by loosening the strap which fastens the exhaust pipes together behind the muffler and detach the pipes from each other. (See DETACH EXHAUST PIPES 1A & 1B) Carefully lower the rear of the muffler and let it hang from the remaining exhaust hanger. Repeat on other side.
3. Fishwire (4) 7/16 x 1" carriage bolts and (4) SP2 spacers into place through the access holes, as shown. (See FISHWIRE TECHNIQUE) Leave fishwires attached to prevent pushing hardware into frame rails during hitch installation.
4. Raise hitch into position and secure hitch with (4) 7/16" flange nuts.
5. Reverse fishwire (1) SP-6 spacer and (1) 1/2 x 1 1/2" carriage bolt into position in mounting hole. (See REVERSE PULL FISHWIRE TECHNIQUE) Place (1) SP32 spacer on the 1/2" carriage bolt then raise the mounting strap into position and secure with (1) 1/2" flange nut.
6. Secure mounting strap to hitch using (2) 7/16 x 1" carriage bolts and (2) 7/16" flange nuts.
7. Torque all 10mm hardware to 35 ft-lbs, 7/16" hardware to 50 ft/lbs and all 1/2" hardware to 75 ft/lbs. Re-install exhaust.

**PERIODICALLY CHECK THIS RECEIVER HITCH TO ENSURE THAT ALL FASTENERS ARE TIGHT AND THAT ALL STRUCTURAL COMPONENTS ARE SOUND.**

Curt Manufacturing Inc., warrants this product to be free of defects in material and/or workmanship at the time of retail purchase by the original purchaser. If the product is found to be defective, Curt Manufacturing Inc., may repair or replace the product, at their option, when the product is returned, prepaid, with proof of purchase. Alteration to, misuse of, or improper installation of this product voids the warranty. Curt Manufacturing Inc.'s liability is limited to repair or replacement of products found to be defective, and specifically excludes liability for incidental or consequential loss or damage.