

INSTALLATION MANUAL

409924

Level of Difficulty

Easy

Installation difficulty levels are based on time and effort involved and may vary depending on the installer level of expertise, condition of the vehicle and proper tools and equipment.

Load Capacity

600 lbs.

Parts List

Qty	Description
1	HighRise™ step assembly
1	HighRise™ step top mounting plate
4	Hex bolt, 1/2"-13 x 6"
4	Nylock nut, 1/2"-13
8	Flat washer, 1/2"

Tools Required

Ratchet	Wrench, 3/4"
Socket, 3/4"	--

Ground Clearance

As vehicle / trailer heights may vary, it is recommended that the operator / installer review for proper ground clearance (6-1/4").

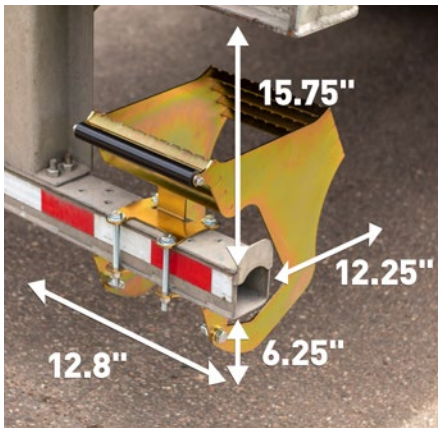

Product Photo



NOTICE

Visit www.retracmirrors.com for a full-color copy of this instruction manual, as well as helpful videos, guides and much more!

Before you begin installation, read all instructions thoroughly.

Proper tools will improve the quality of installation and reduce the time required.

Periodic inspection of your product should be performed to ensure all hardware and / or components remain secure.

SAFETY INSTRUCTIONS

Always use three points of contact when using this product.

Maintenance

Mild automotive detergent may be used to clean the product. Do not use dish detergent, abrasive cleaners, abrasive pads, wire brushes or other similar products that may damage the finish.

Product Registration and Warranty

RETRAC stands behind our products with industry-leading warranties. To get copies of the product warranties, register your purchase or provide feedback, visit: warranty.curtgroup.com/surveys

Step 1

Pre-install two bolts into the step assembly and top mounting plate rear holes.

Hand tighten the hardware at this time.



Step 2

Slide the step assembly over the 4"x 4" trailer bumper and insert the two front bolts.



Step 3

Evenly tighten the bolts until both the top mounting plate and bottom step pivot plate are in contact with the bumper.

Do not fully tighten at this time.



Step 4

With the step folded down, adjust the mounting plates until the back side of the bumper is in complete contact with both step side plates.

Tighten the bolts until the mounting plate is secure. Do not bend the mounting hole tabs. Put the step in the stow position when not in use.

