

INSTALLATION MANUAL

206970

Level of Difficulty

Easy

Installation difficulty levels are based on time and effort involved and may vary depending on the installer level of expertise, condition of the vehicle and proper tools and equipment.

Parts List

Qty	Description
1	Mounting bracket, driver / left
1	Mounting bracket, passenger / right
1	Adjustable mounting bracket, driver / left
1	Adjustable mounting bracket, Passenger / right
2	Tow hook mounting bar
2	Mounting bracket spacer
2	Maglatch bracket
2	Hex bolt, 3/4"-10 x 2"
2	Hex bolt, 3/4"-10 x 3"
6	Hex bolt, 5/8"-11 x 1-3/4"
2	Shoulder bolt, 5/8" x 7/8" x 1/2"-13
4	Lock washer, 3/4"
2	Flat washer, 5/8"
4	Flat washer, 9/16"
4	Belleville washer, .63" x 1.25" x .04" x .042"
4	Flange nut, 5/8"-11
2	Nylock nut, 5/8"-11
2	Nylock nut, 1/2"-13

Tools Required

Ratchet	Socket, 15/16"
Torque wrench	Socket, 1-1/8"
Wrench, 15/16"	Socket, 3/4"
Allen wrench, 5/16"	--

Torque Specifications

1/2" bolt	65 ft-lbs.
5/8" bolt	128 ft-lbs.
3/4" bolt	228 ft-lbs.

Use above torque setting unless otherwise noted

Product Photo

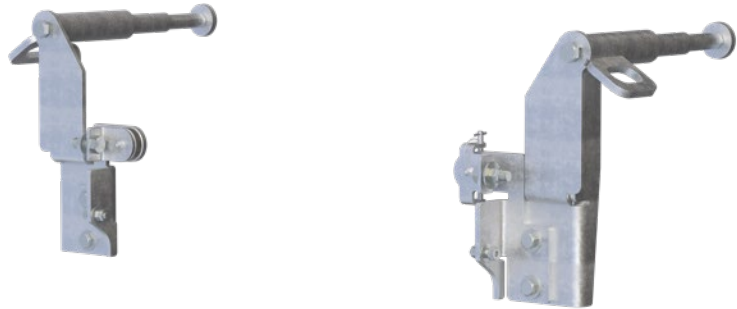

NOTICE

Visit www.retracmirrors.com for a full-color copy of this instruction manual, as well as helpful videos, guides and much more!

Before you begin installation, read all instructions thoroughly.

Proper tools will improve the quality of installation and reduce the time required.

Periodic inspection of your product should be performed to ensure all hardware and / or components remain secure.

To help prevent damage to the product or vehicle, refer to the specified torque specifications when securing hardware during the installation process.

Maintenance

Mild automotive detergent may be used to clean the product. Do not use dish detergent, abrasive cleaners, abrasive pads, wire brushes or other similar products that may damage the finish.

Product Registration and Warranty

RETRAC stands behind our products with industry-leading warranties. To get copies of the product warranties, register your purchase or provide feedback, visit: warranty.curtgroup.com/surveys

Step 1

Remove factory tow hook pins if installed.

Insert mounting bars into the tow hook receivers on the truck. Open the hood and install the mounting bracket spacer on the back side of the tow hook tube with a 3/4" lock washer and 3/4-10 x 2" bolt. Hand tighten at this time, mounting bar will be loose until mounting brackets are installed.

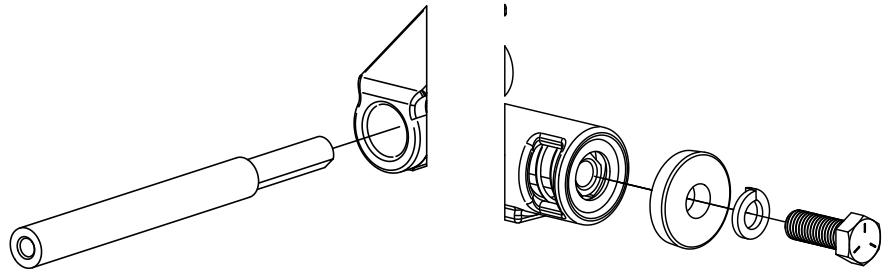

Step 2

Slide a mounting bracket over each tow hook mounting bar until the end of the tube rests against the truck frame and secure with 3/4" - 10 x 3" bolt with 3/4" lock washer.

Keep the bracket square on the truck and tighten with the 1-1/8" socket. Verify lock washers on both inside and outside bolts are fully compressed and bolts are fully torqued.

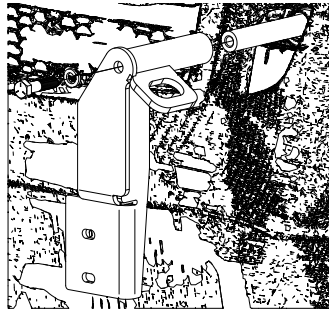

Step 3

Using the 5/8"-11 x 1-3/4" bolts, 9/16" flat washers and 5/8"-11 flange nuts, secure the adjustable mounting brackets to the mounting brackets. Hand tighten at this time.

Driver side with plastic bumper shown.

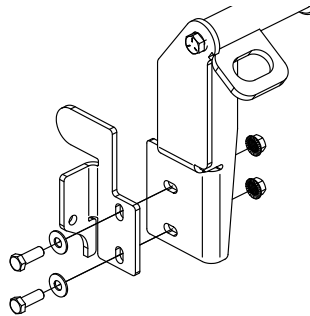

Step 4

Using the 5/16" allen wrench and 3/4" socket, install the guard onto the mounting brackets with the 5/8" x 7/8" shoulder bolts, .63 x 1.25 x .040 x .082 belleville washers (large diameter to the guard bracket face) and 1/2"-13 nylock nuts using the bottom holes. (Driver side shown)

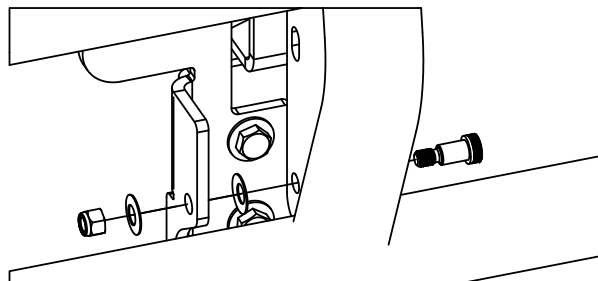

Step 5

Using a 15/16" socket and wrench, attach the magnet bracket assemblies to the mounting bracket of the grille guard with the 5/8"-11 x 1-3/4" bolts, 5/8" flat washer and 5/8"-11 nylock nuts. The safety pin bracket must be on the driver side. (Driver side shown)

Note: Magnets and brackets are pre-assembled, some adjustment may be necessary after the grille guard is installed on the truck.

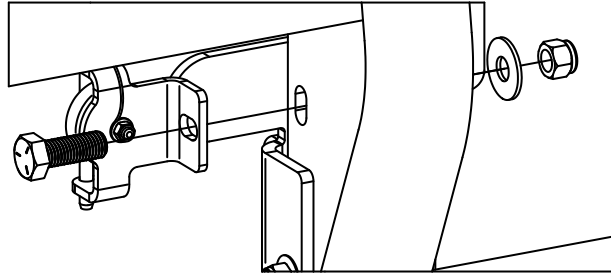

Step 6

Adjust the guard as needed to center on the truck and tighten the adjustable mounting bracket bolts according to the torque specifications on page 1.