

INSTALLATION INSTRUCTIONS AND PARTS LIST

UNIVERSAL BED RAIL WITH TIE DOWNS:

516100 100" BLACK ANODIZED / **518100** 100" CHROME PLATED

1. Read instructions completely and check to make sure that all required parts are on hand before starting the installation. See **fig 1**.

2. **ATTACH THE ALUMINUM BASE TO THE TRUCK:**
 - 2.1 If the truck has plastic bed caps it will be necessary to cut these out so that the stake pockets are accessible. **BE CAREFUL NOT TO CUT THE OPENING ANY LARGER THAN THE BLACK BASE WILL COVER.**
 - 2.2 The stake pockets on the trucks are various sizes, so we have supplied (2) different size mounting plates. Please take some time to determine which mounting plate will work for your application (item #3 or item #4). **YOU WILL NOT USE BOTH PLATES IN EACH STAKE POCKET.** However you may use a large plate in one pocket, and a small plate in the opposite pocket. See **fig 2**.
 - 2.3 Once you have determined which mounting plates to use, please assemble the 5/16-18 multi thread u-nut (item #5) to the mounting plates (item #3 or item #4) as shown in **fig 2**.
 - 2.4 Place the 5/16-18 x 3-1/4" Button head screw (item #6) into the black aluminum base (item #2). And start the bolt into the multi thread u-nut. Do not tighten down.
 - 2.5 Snake the retainer plate into the front stake pocket so that the top edges are catching on the underside of the bed box. While applying upward pressure, use a hex wrench to tighten down the button head screw. Keeping the base in line with the back stake pocket. Snug down at this time.
 - 2.6 Repeat for the middle and rear stake pockets. Use a bed rail to make sure the three bases line up. The **Maximum** overall dimension at the top of the black bases is 96". See **fig 2**.
 - 2.7 **TIGHTEN DOWN.**
 - 2.8 Repeat 2.1 through 2.7 for the opposite side.

3. **ASSEMBLE U-BOLT AND THE BED RAIL ASSEMBLY:**
 - 3.1 Assemble the u-bolts (item #7) with the serrated flange nuts (item #8), and square nuts (item #9) as shown in **fig 3**. Make sure there is a gap between the (2) nuts.
 - 3.2 Load each bed rail with the appropriate number of square headed nuts (item #9) and U-bolt assemblies as shown in **fig 3**. Make sure that you place (2) square nuts in front of the forward u-bolt assembly, (2) square nuts between the U-bolt assemblies, and (2) square nuts behind the back U-bolt Assembly.
 - 3.3 Attach the Plastic End Caps (item #10) to the Bed Rail by using the #8 x 1/2" self drilling screw (item #11). Drill through the thin blade into the recessed slot of the bed rail.
 - 3.4 Repeat 3.1 through 3.3 for the opposite side.

4. **ATTACH THE BED RAIL ASSEMBLY TO THE BLACK ALUMINUM BASE:**
 - 4.1 Lay the bed rail assembly on top of the aluminum bases (item #2). Tip the rail up slightly on the side and line up the square nuts with the holes in the base, and lay back down.
 - 4.2 Using the 3/8-16 x 3/4" hex screw, (item #12) attach the base to the bed rail. Start all the bolts before tightening them down as shown in **fig. 4**.
 - 4.3 After all the bolts have been started do some final adjustment fore and aft centering the rail on the pickup box and tighten down the bolts.
 - 4.4 Repeat 4.1 through 4.3 for the opposite side.



1200 E. Birch St.

Brandon, SD 57005

REV A 06OCT11
510084 SHEET 1 of 4 10MAY11

SERVICE PARTS LIST

| ITEM | PART NO. | QTY | DESCRIPTION |
|------|----------|-----|--|
| 1 | 108694 | 2 | 97" ALUMINUM BED RAIL EXTRUSION, BLACK 516100 |
| 1 | 108697 | 2 | 97" ALUMINUM BED RAIL EXTRUSION, CHROME 518100 |
| | | | |
| 2 | 510076 | 6 | BASE-ALUMINUM, BLACK |
| 3 | 510074 | 6 | PLATE-MTG, GALV. LARGE, BED RAIL |
| 4 | 510075 | 6 | PLATE-MTG, GALV. LARGE, BED RAIL |
| 5 | 105541 | 6 | NUT-MULTI THREAD, 5/16-18, BLACK |
| 6 | 107867 | 6 | SCR-BTN HEAD, 5/16-18 X 3.25, ZP WITH PATCH |
| 7 | 510089 | 4 | U-BOLT, 3/8-16 X 1.38,SST,BZP |
| 8 | 106995 | 8 | NUT-SERR FLANGE, HEX, 3/8-16,SST,BZP |
| 9 | 107865 | 20 | NUT-SQUARE, 3/8-16,SST,BZP |
| 10 | 108699 | 4 | END CAP-PLASTIC, BLACK |
| 11 | 107958 | 4 | SCR-TEK, #8 X 1/2",SST,BZP |
| 12 | 107866 | 12 | SCR-HEX, 3/8-16 X 3/4",SST,BZP |
| 13 | 107871 | 6 | GASKET-FOAM, 1/16"X2.19X3.94,XLPE |



(A LIVERNE Company)

1200 E. Birch St.

Brandon, SD 57005

REV A 06OCT11
510084 SHEET 2 of 4 10MAY11

SERVICE PARTS LIST

-MODEL NO.-
516100
518100

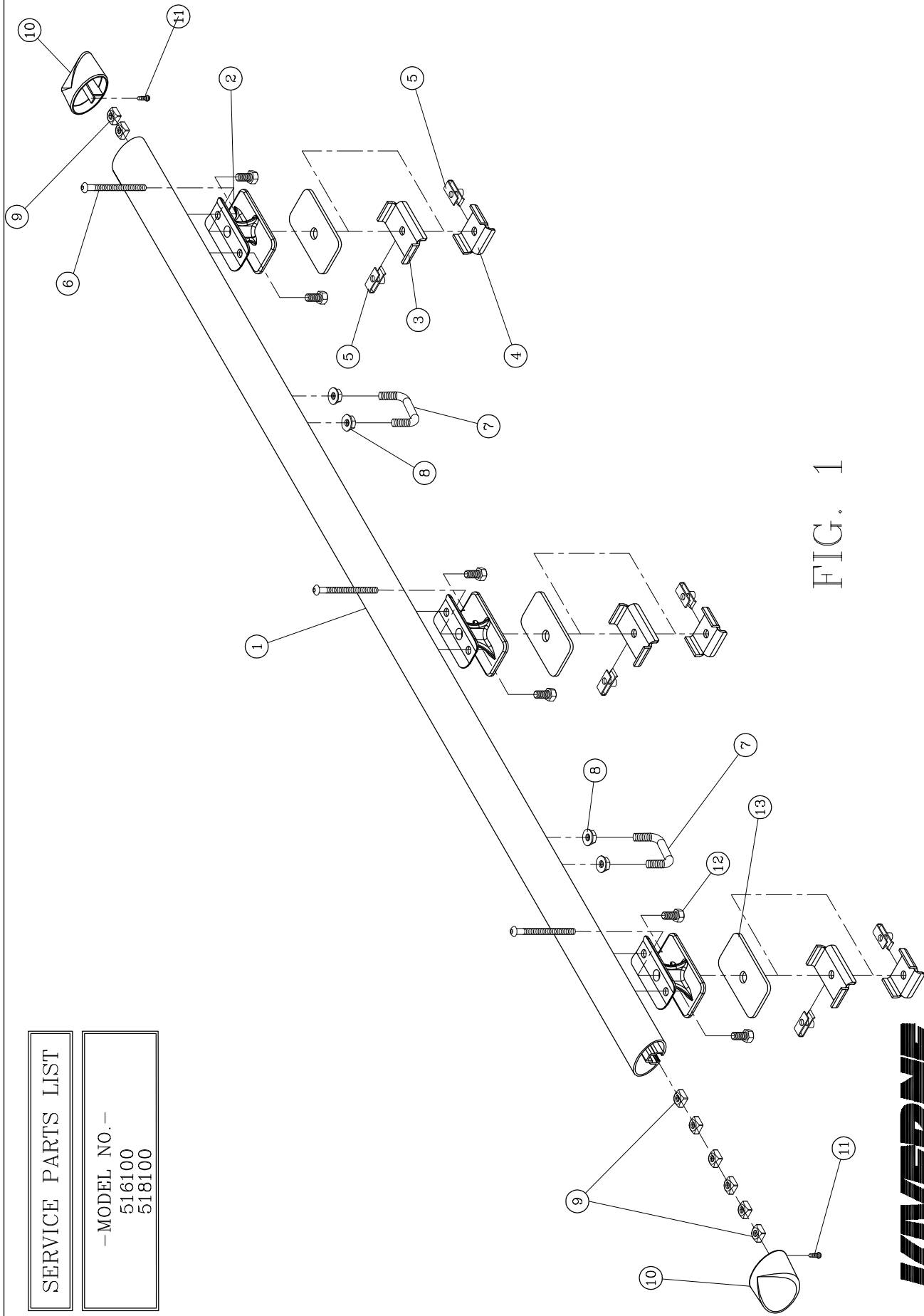

FIG. 1



1200 E. Birch St.
Brandon, SD 57805

REV A 06OCT11

510084 SHEET 3 OF 4 10MAY11

SERVICE PARTS LIST

-MODEL NO.-
516100
518100

96" MAX.
FOR 516100 & 518100

USED FOR LARGE
STAKE POCKETS

USED FOR SMALL
STAKE POCKETS

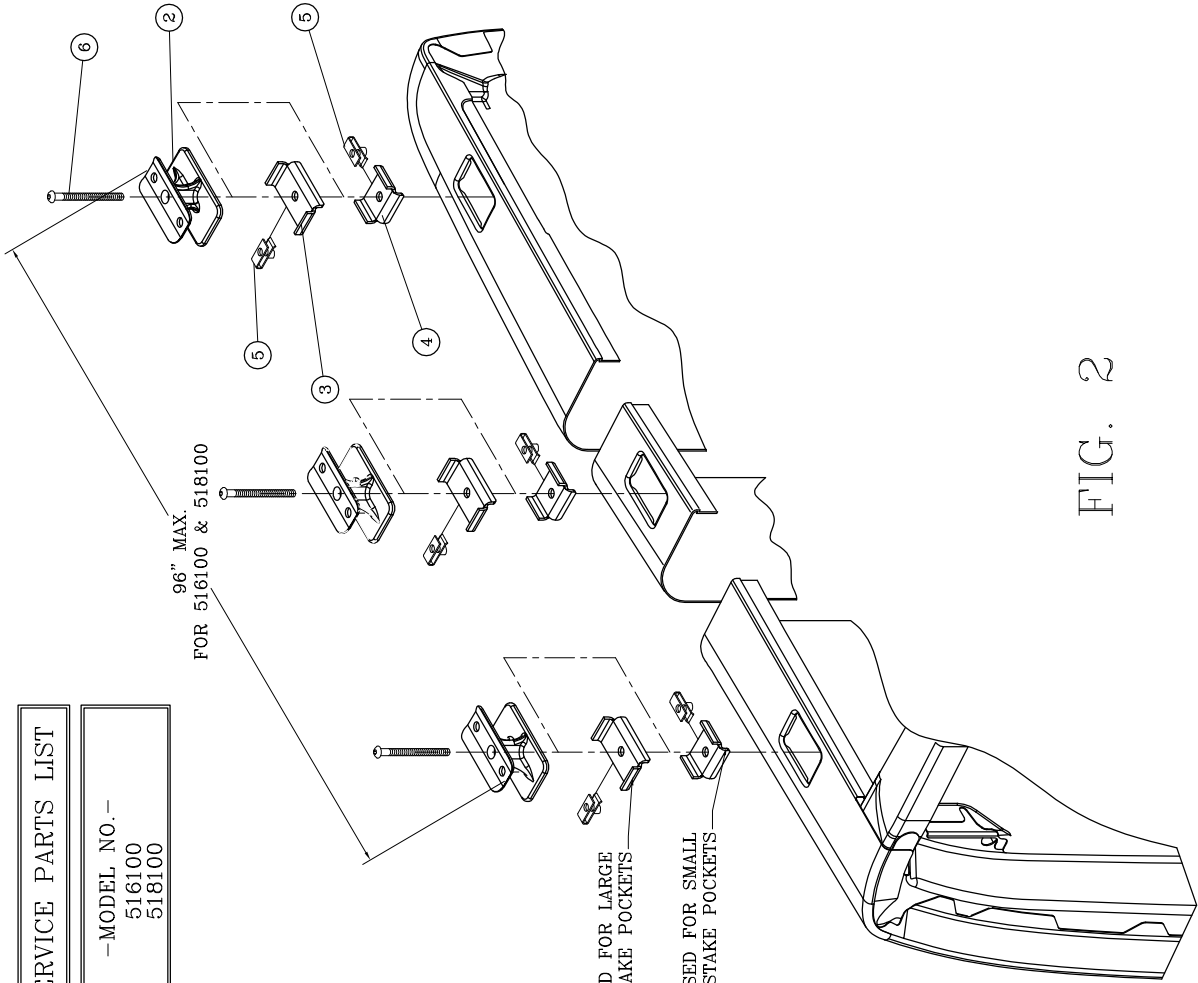

FIG. 2

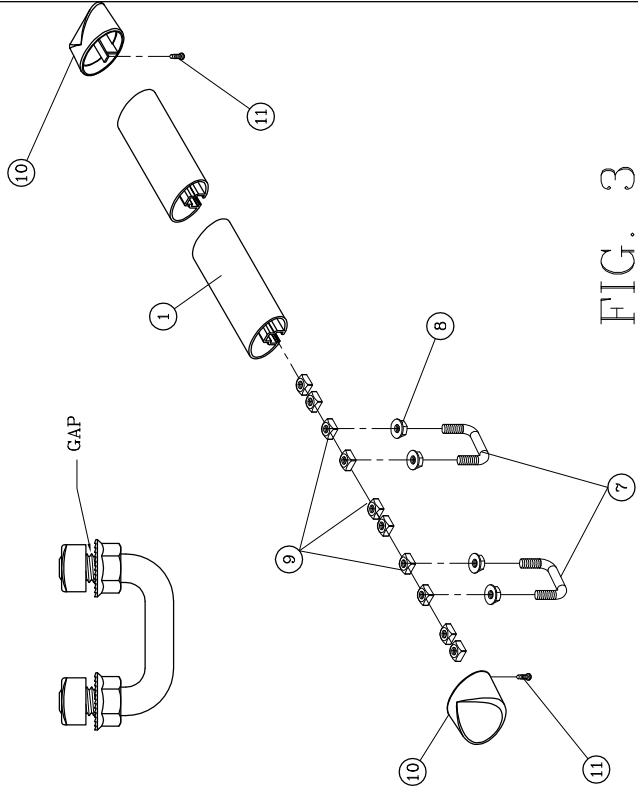

FIG. 3

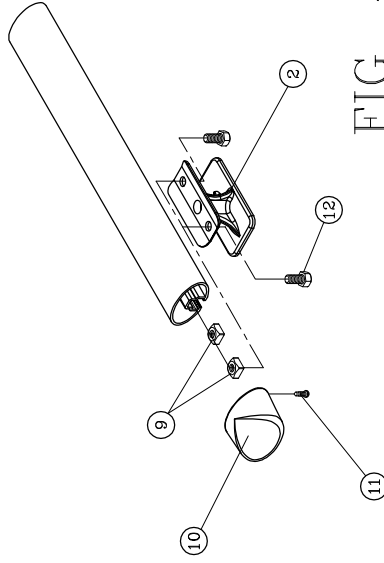

FIG. 4

LOVERNE
TRUCK EQUIPMENT

(A LOVERNE COMPANY)

1200 E. Birch St.

Granville, OH 57065

REV A 06OCT11

510084 SHEET 4 OF 4 10MAY11