



## INSTALLATION INSTRUCTIONS FOR MOUNTING STAKE POCKET BED RAILS – MODEL #'s 510080,510090

### TRUCK MODELS:

**510080** 2007+ GM 5.8' BOX

**510090** 2007+ GM 6.5' BOX

1. READ THE INSTRUCTIONS COMPLETELY AND CHECK TO MAKE SURE THAT ALL OF THE REQUIRED PARTS ARE ON HAND BEFORE STARTING THE INSTALLATION.
2. PREASSEMBLE MULTI THREAD U-NUT (ITEM #4) TO THE LARGE GALV. PLATE (ITEM #3) AS SHOWN IN FIGURE #1. REPEAT FOR ALL 4 PLATES.
3. ASSEMBLE THE BED RAIL ASSEMBLY:
  - A. INSERT THE 5/16-18 X 2-1/2" SST BUTTON HEAD SCREW (ITEM #6) THROUGH ACCESS HOLE AND ATTACH TO THE BED RAIL (ITEM #1) THROUGH THE WELD PLATE.
  - B. SLIDE THE PLASTIC PLATE (ITEM #2) OVER THE 5/16" SCREW (ITEM #6), AND ATTACH THE NUT PLATE ASSEMBLY (ITEM #3,4) TO THE BOLT SO THAT THE THREADS ARE JUST TO THE BOTTOM END OF THE U-NUT.
4. PLACE THE BED RAIL ASSEMBLY OVER THE STAKE POCKETS AND CAREFULLY WORK THE NUT PLATE ASSEMBLY INTO THE STAKE POCKETS.
5. USING A 3/16" ALLEN HEAD WRENCH, TIGHTEN DOWN THE BED RAIL TO THE TOP OF THE BED. MAKE SURE THAT THE PLASTIC SPACER COVERS BOTH STAKE POCKETS.
6. INSERT THE 9/16" DIA HOLE PLUG (ITEM #5) INTO BED RAIL ASSEMBLY.
7. REPEAT FOR OPPOSITE SIDE.

ITEM	PART #	QTY	DESCRIPTION
1	510082	2	TUBE WLDMT 60.69" #510080
1	510092	2	TUBE WLDMT 70.19" #510090
2	104845	4	SPACER-PLASTIC 2.25 X 3.50
3	510074	4	PLATE-MTG, GALV. LARGE, BED RAIL
4	105541	4	MULTI THREAD U-NUT 5/16-18
5	104844	6	PLUG, BPF 9/16, BLACK LDPE
6	104837	4	5/16-18 X 2-1/2" SST BTN HD SCREW



MODEL NO.	510080
	510090

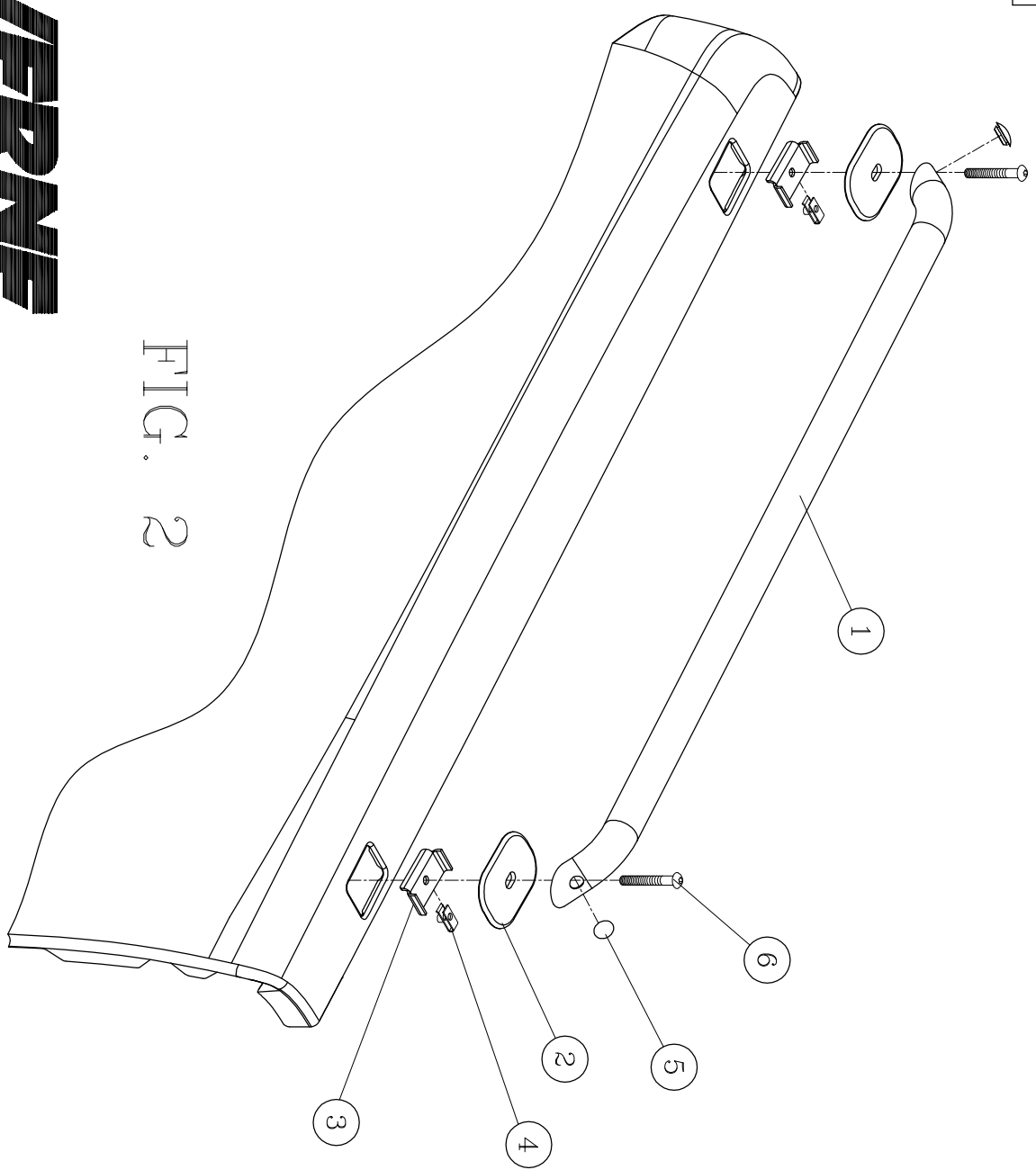

FIG. 2

