

INSTALLATION INSTRUCTIONS AND PARTS LIST

APPLICATION:

46/451515, 46/451510 SERIES POLISHED STAINLESS STEEL & BLACK NERF BARS ON:
2015+ GM COLORADO/ CANYON CREW CAB PICKUPS
2015+ GM COLORADO/ CANYON EXTENDED CAB PICKUPS



NO DRILL APPLICATION

1. READ INSTRUCTIONS COMPLETELY AND CHECK TO MAKE SURE THAT ALL REQUIRED PARTS (LISTED ON SERVICE PARTS LIST) ARE ON HAND BEFORE STARTING THE INSTALLATION.
2. NERF BAR TUBE AND MOUNTING BRACKET ARE PRE-ASSEMBLED.
NOTE: THE 1" X 3" SERIAL NUMBER DECAL IS LOCATED ON THE FRONT LEG OF THE LEFT (DRIVERS SIDE) NERF BAR ASSEMBLY.

NOTE:

DUE TO EXCESSIVE THREAD LOCKER IN THE BODY MOUNT BOLT AREA ON THE GM COLORADO/CANYON, PLEASE USE CAUTION WHEN REMOVING THESE BODY MOUNT BOLTS IN ORDER TO REDUCE THE RISK OF CAUSING DAMAGE TO THE THREADED INSERTS INSIDE THE VEHICLE.

3. ASSEMBLE THE LOAD REACTION BOLT TO THE REAR BRACE AS SHOWN IN FIGURE 1,
 - 3.1. INSTALL A 3/8"-16 FLANGE NUT (ITEM #10) BACKWARDS, TO THE END OF THE THREAD, ON EACH END OF THE THREADED STUD (ITEM #8).
 - 3.2. ON THE INBOARD SIDE OF THE STUD, INSTALL A 3/8" FLAT WASHER (ITEM #11). THEN PUSH THE 3/4" THICK RUBBER WASHER (ITEM #9) TIGHT UP AGAINST THE FLANGE NUT. **(THE END OF THE THREADED STUD SHOULD BE RECESSED AT LEAST 1/8" BACK IN THE HOLE OF THE RUBBER WASHER).** INSTALL THE OUTBOARD END OF THE STUD ASSEMBLY THRU THE HOLE IN THE MOUNTING BRACKET AND INSTALL A 3/8" FLANGE NUT (ITEM #10) FINGER TIGHT ONLY.
4. ON THE LEFT SIDE OF THE VEHICLE REMOVE THE FRONT AND REAR FACTORY BODY MOUNT BOLTS FROM THE VEHICLE.
 - 4.1. THESE BOLTS ARE NOT REUSED IN THIS INSTALLATION.
 - 4.2. THE BODY MOUNT STEEL WASHER PLATES WITH RUBBER CUSHIONS ARE REUSED BETWEEN THE BODY MOUNT AND THE NERF BAR MOUNTING BRACKET.
5. POSITION THE LH SIDE NERF BAR ASSEMBLY UP UNDER THE VEHICLE AND USING TWO M14-2.00 X 130 MM BOLTS (ITEM #5) AND TWO 9/16" FLAT WASHERS (ITEM #7) ATTACH THE FRONT AND REAR BRACKETS (ITEMS #3,4) TO THE BODY MOUNTS AS SHOWN IN FIGURE 1.
6. ADJUST THE LOAD REACTION STUD SO THAT THE RUBBER WASHER IS SNUG AGAINST THE FRAME OF THE VEHICLE AND TIGHTEN DOWN.
7. TORQUE ALL BODY MOUNT BOLTS TO 65 LB. FT.
8. REPEAT FOR RIGHT SIDE OF VEHICLE.



1200 E. Birch St.

Brandon, SD 57005

REV A 10MAR15
552710 SHEET 1 OF 3 17DEC14

SERVICE PARTS LIST

ITEM	PART NO.	QTY	DESCRIPTION
1	552712	1	NB TUBE – 15+ COLORADO/CANYON, CREW, LH, BLACK
2	552713	1	NB TUBE – 15+ COLORADO/CANYON, CREW, RH, BLACK
1	552706	1	NB TUBE – 15+ COLORADO/CANYON, CREW, LH, SST
2	552707	1	NBTUBE – 15+ COLORADO/CANYON, CREW, RH, SST
1	552849	2	NB TUBE – 15+ COLORADO/CANYON, EXT, LH/RH, BLK
1	552848	2	NB TUBE – 15+ COLORADO/CANYON, EXT, LH/RH, SST
3	552708	2	BRKT-MTG,NB,GM,REG/EXT FRONT
4	552709	2	BRKT-MTG,NB,GM, LH/RH,REAR
5	107199	4	BOLT-HEX, M14-2.00 X 130 MM, ZP
6	104249	4	BOLT-HEX, FLNG, 1/2" – 13 X 2.00"
7	100140	4	WASHER-FLAT, 9/16", ZP
8	104686	2	STUD-DBL END, .3/8"-16 X 4.00", ZP
9	102592	2	WSHR-RUBBER, .354 X 1.00 X .748
10	100181	6	NUT-HEX, FLNG, 3/8"-16, ZP
11	100062	2	WASHER-FLAT, 3/8"



(A LIVERNE Company)

1200 E. Birch St.

Brandon, SD 57005

REV A 10MAR15
552710 SHEET 2 OF 3 17DEC14

SERVICE PARTS LIST

- MODEL NO. -451515 (BLACK)
- 461515 (SST)
- 451510 (BLACK)
- 461510 (SST)

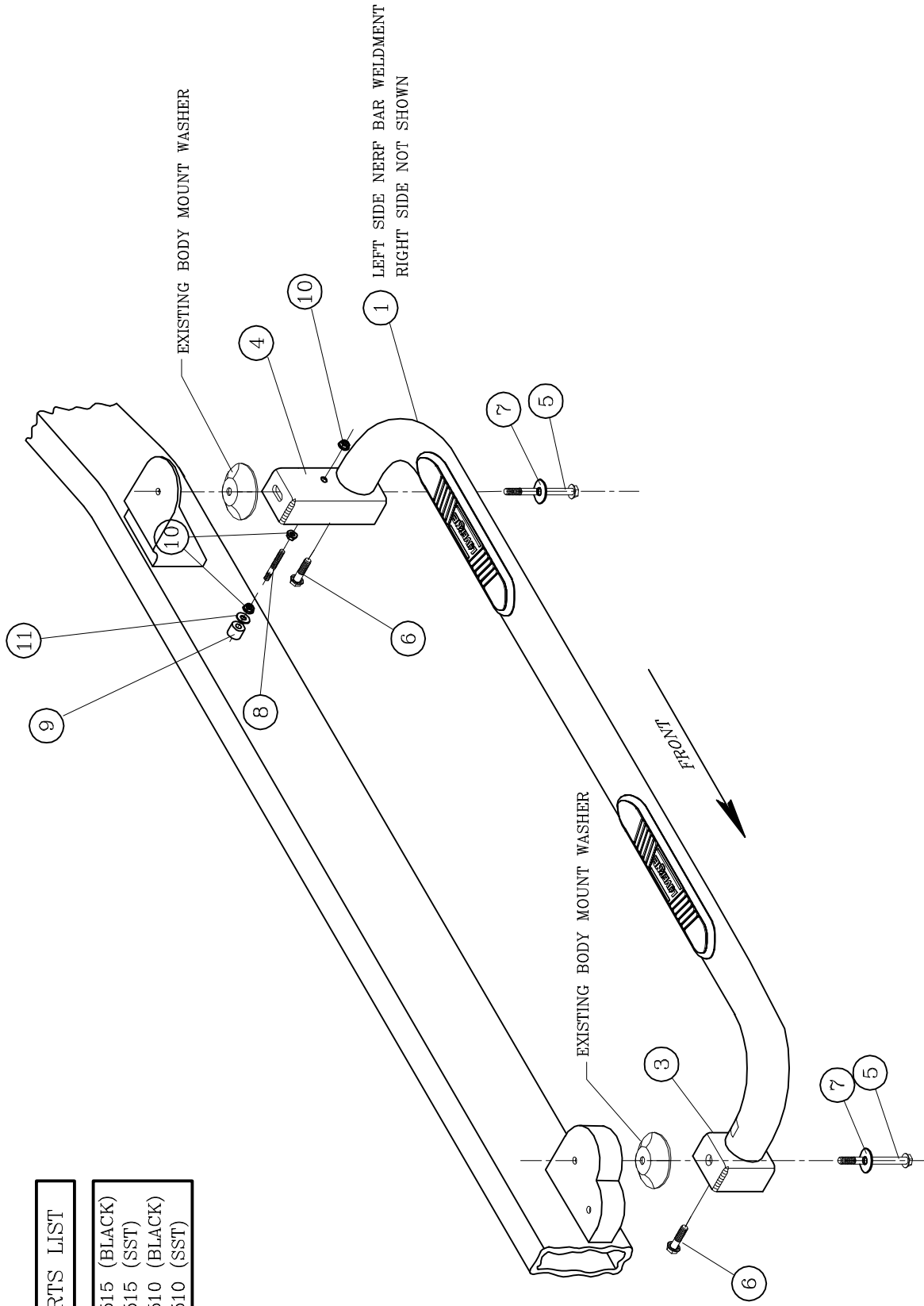

LOVERNE
TRUCK EQUIPMENT
(A LOVERNE Company)

1200 E. 4th St. Brookton, SD 57005

LEFT (DRIVER) SIDE SHOWN
-RIGHT (PASSENGER) SIDE OPPOSITE-