

# INSTALLATION INSTRUCTIONS AND PARTS LIST

## STAINLESS STEEL AND BLACK W2W NERF BAR:

**45/460937** 2009 AND NEWER DODGE RAM **QUAD** CAB 6.7 BOX

**45/460939** 2009 AND NEWER DODGE RAM **CREW** CAB 5.5 BOX



1. READ INSTRUCTIONS COMPLETELY AND CHECK TO MAKE SURE THAT ALL REQUIRED PARTS (LISTED ON SERVICE PARTS LIST) ARE ON HAND BEFORE STARTING THE INSTALLATION.
2. NERF BAR TUBE AND MOUNTING BRACKET ASSEMBLIES ARE PRE-ASSEMBLED.
  - 2.1. THE FRONT AND REAR MOUNTING BRACKETS ON THESE ASSEMBLIES ARE ROTATED INBOARD OF THE LEGS FOR SHIPPING PURPOSES. THESE BRACKETS MUST BE ROTATED TO THE VERTICAL POSITION AND THE ½" BOLTS MUST BE TORQUED TO 65 LB FT.
3. ASSEMBLE THE DOUBLE ENDED STUD & FASTENERS TO THE FRONT & REAR BRACES AS FOLLOWS,
  - 3.1. INSTALL 3/8" SERRATED FLANGE NUTS (ITEM #14) **BACKWARDS**, TO THE END OF THE THREAD, ON EACH END OF THE DOUBLE ENDED STUD (ITEM #13).
  - 3.2. ON THE SHORT THREADED END OF THE STUD, INSTALL A 3/8" FLAT WASHER (ITEM #15). THEN, PUSH THE ¾" THICK RUBBER WASHER (ITEM #16) & FLAT WASHER TIGHT UP AGAINST THE SERRATED FLANGE NUT. (THE END OF THE DOUBLE ENDED STUD SHOULD BE RECESSED BACK IN THE HOLE OF THE RUBBER WASHER APPROXIMATELY 3/16").
  - 3.3. INSTALL THE LONG THREADED END OF THE STUD ASSEMBLY THRU THE HOLE IN THE MOUNTING BRACKET (JUST ABOVE THE NERF BAR TUBE) AND INSTALL A 3/8" SERRATED FLANGE NUT AS SHOWN. (FINGER TIGHT ONLY).
4. REMOVE THE FOUR (4) APPLICABLE M12-1.75 BODY MOUNT BOLTS FROM THE VEHICLE. **(THE FRONT BOLTS AND WASHERS ARE NOT REUSED).**
5. POSITION THE NERF BAR ASSEMBLY UP UNDER THE BODY MOUNT METAL BUSHING:
  - 5.1. ON THE FRONT BODY MOUNTS, INSTALL M12-1.75 X 110mm (APPROX. 4-3/8" LONG) HEX HEAD BOLTS (ITEM #12), 1/2" LOCK WASHERS (ITEM #10) AND ½" FLAT WASHERS (ITEM #11) UP THRU THE HOLE IN THE NERF BAR MOUNTING BRACKET AND THE BODY MOUNTING BUSHING AS SHOWN.
  - 5.2. **2009 TO 2012-** ON THE REAR BODY MOUNT INSTALL THE FACTORY BOLT AND WASHER THRU THE HOLE IN THE NERF BAR MOUNTING BRACKET AND BODY MOUNT BUSHING AS SHOWN IN **FIG. 1 OR 2.**
  - 5.3. **2013-** ON THE REAR BODY MOUNT FLIP THE CAST IRON BODY MOUNT DAMPENER OVER AND INSTALL TWO 3/4" FLAT WASHERS INSIDE THE DISH OF THE DAMPENER, PLACE THE FACTORY BODY MOUNT BOLT AND WASHER THROUGH THE NERF BAR BRACKET THEN THROUGH THE DAMPENER, AND 3/4" WASHERS AS SHOWN IN **FIG. 3 OR 4.**
  - 5.4. TORQUE ALL M12-1.75 BODY MOUNTING BOLTS TO 45 LB. FT.
  - 5.5. POSITION THE STUD ASSEMBLIES SO THAT THE RUBBER WASHER IS SNUG UP AGAINST THE FRAME. TIGHTEN THE 3/8" SERRATED FLANGE NUTS ON EITHER SIDE OF THE REAR BRACKET TO LOCK THE STUD ASSEMBLY IN POSITION.

## INSTALLATION INSTRUCTIONS AND PARTS LIST

STAINLESS STEEL AND BLACK W2W NERF BAR:

**45/460937** 2009 AND NEWER DODGE RAM **QUAD** CAB 6.7 BOX

**45/460939** 2009 AND NEWER DODGE RAM **CREW** CAB 5.5 BOX

### SERVICE PARTS LIST

ITEM	PART NO.	QTY	DESCRIPTION
1	551138	1	NERF BAR WLDMT- W2W,LH,SST,460937
2	551139	1	NERF BAR WLDMT- W2W,RH,SST,460937
1	551478	1	NERF BAR WLDMT- W2W,LH,SST,460939
2	551479	1	NERF BAR WLDMT- W2W,RH,SST,460939
1	551140	1	NERF BAR WLDMT- W2W,LH,BLK,450937
2	551141	1	NERF BAR WLDMT- W2W,RH,BLK,450937
1	551480	1	NERF BAR WLDMT- W2W,LH,BLK,450939
2	551481	1	NERF BAR WLDMT- W2W,RH,BLK,450939
3	551149	2	SPCR TUBE, 450637
4	551112	2	TRIM, SPCR TUBE
5	551468	2	MOUNTING BRACKET FRONT, LH/RH
6	551469	2	MOUNTING BRACKET REAR, LH/RH
7	104249	4	SCREW-HEX HEAD, SER FLNG,1/2-13 X 2.0, ZP
8	103950	6	PAD-STEP, NB, BLK, 20.00 LG
9	102500	2	INSR-FNSH, RIBBED, 14-18 GA TUBE
10	100121	2	WASHER-LOCK,1/2",ZP
11	100118	2	WASHER-FLAT,1/2",ZP
12	103444	2	BOLT- HEX HD CAP, M12-1.75 X 110mm
13	108448	4	STUD-DOUBLE ENDED,STL,3/8-16 UNC X 6.00",ZP
14	100181	12	NUT-SERRATED FLANGE,HEX,3/8-16 UNC,ZP
15	100062	4	WASHER-FLAT, 3/8", ZP
16	102592	4	WASHER-RUBBER,.354 ID X 1.00 OD X .75 THK
17	106299	2	PAD-TAPE,4.00 X 6.00
18	100153	4	WASHER-PL,A ,3/4", .812 X 2.0 X .148, ZP

SERVICE PARTS LIST

MODEL NO. -450937/460937

2009-2012 RAM 1500

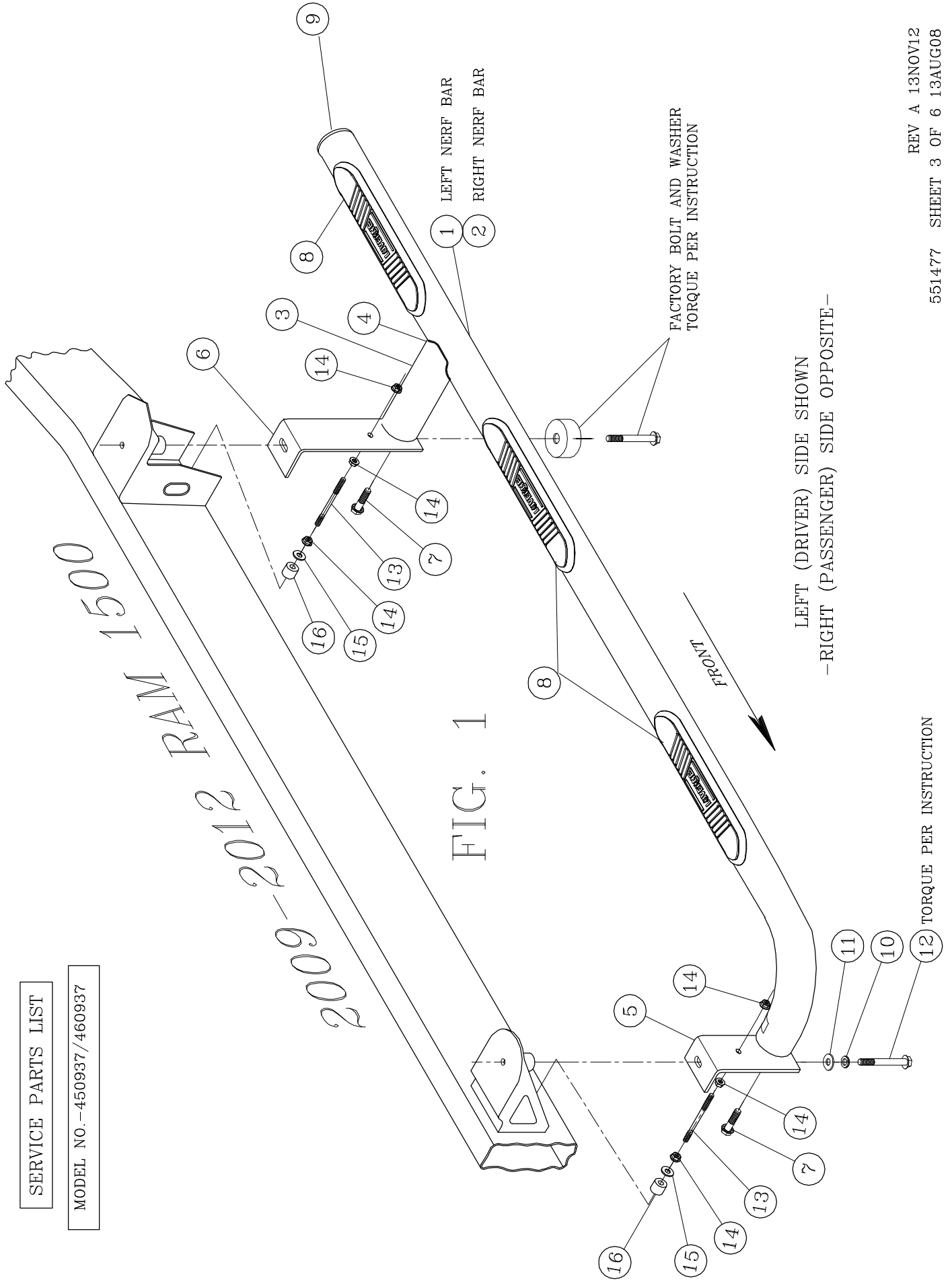

FIG. 1

LEFT (DRIVER) SIDE SHOWN  
-RIGHT (PASSENGER) SIDE OPPOSITE-

TORQUE PER INSTRUCTION

SERVICE PARTS LIST

MODEL NO. -450939/460939

2009-2012 RAM 1500

FIG. 2

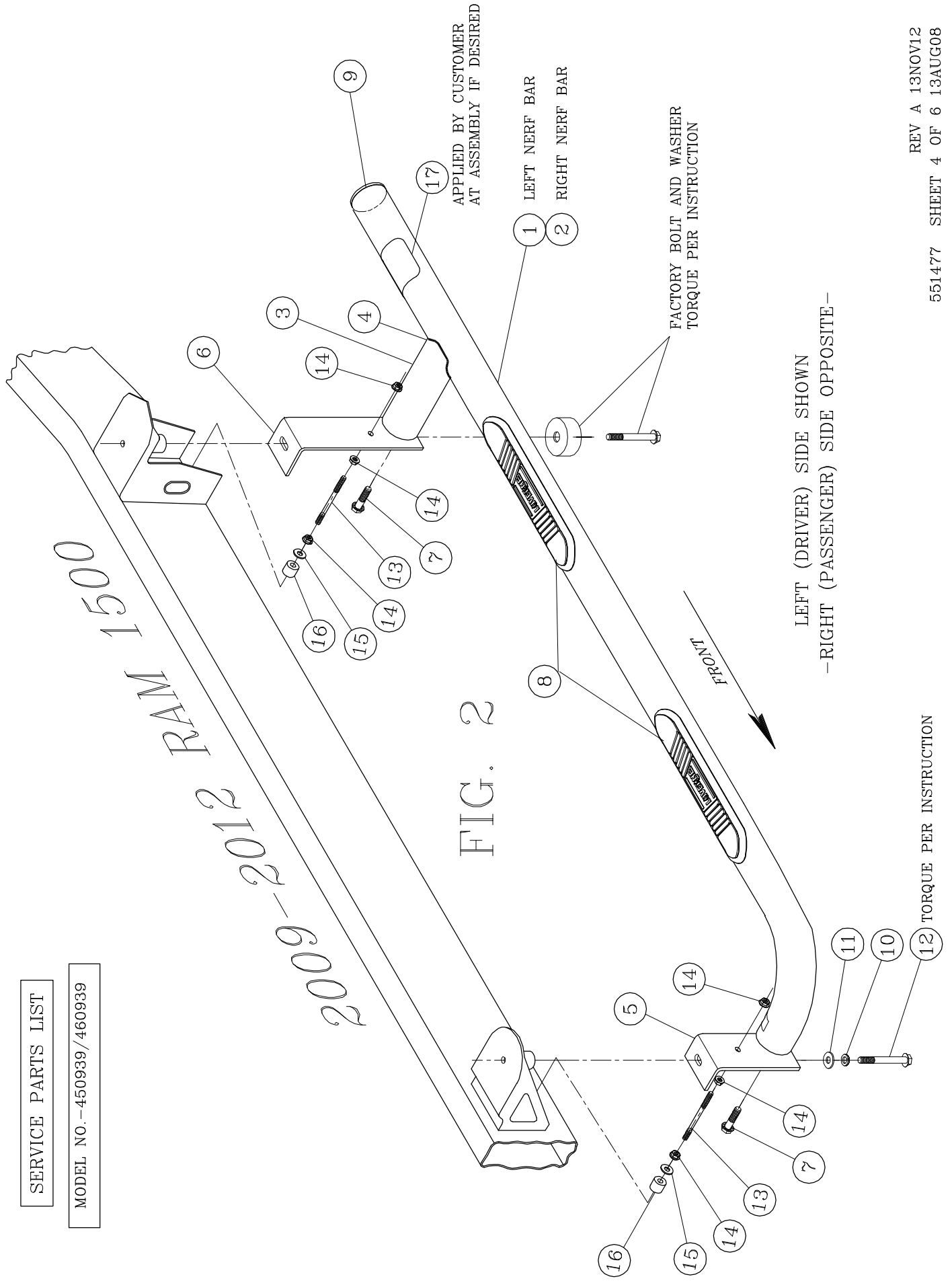

12 TORQUE PER INSTRUCTION

SERVICE PARTS LIST

MODEL NO. -450937/460937

2013 RAM 1500

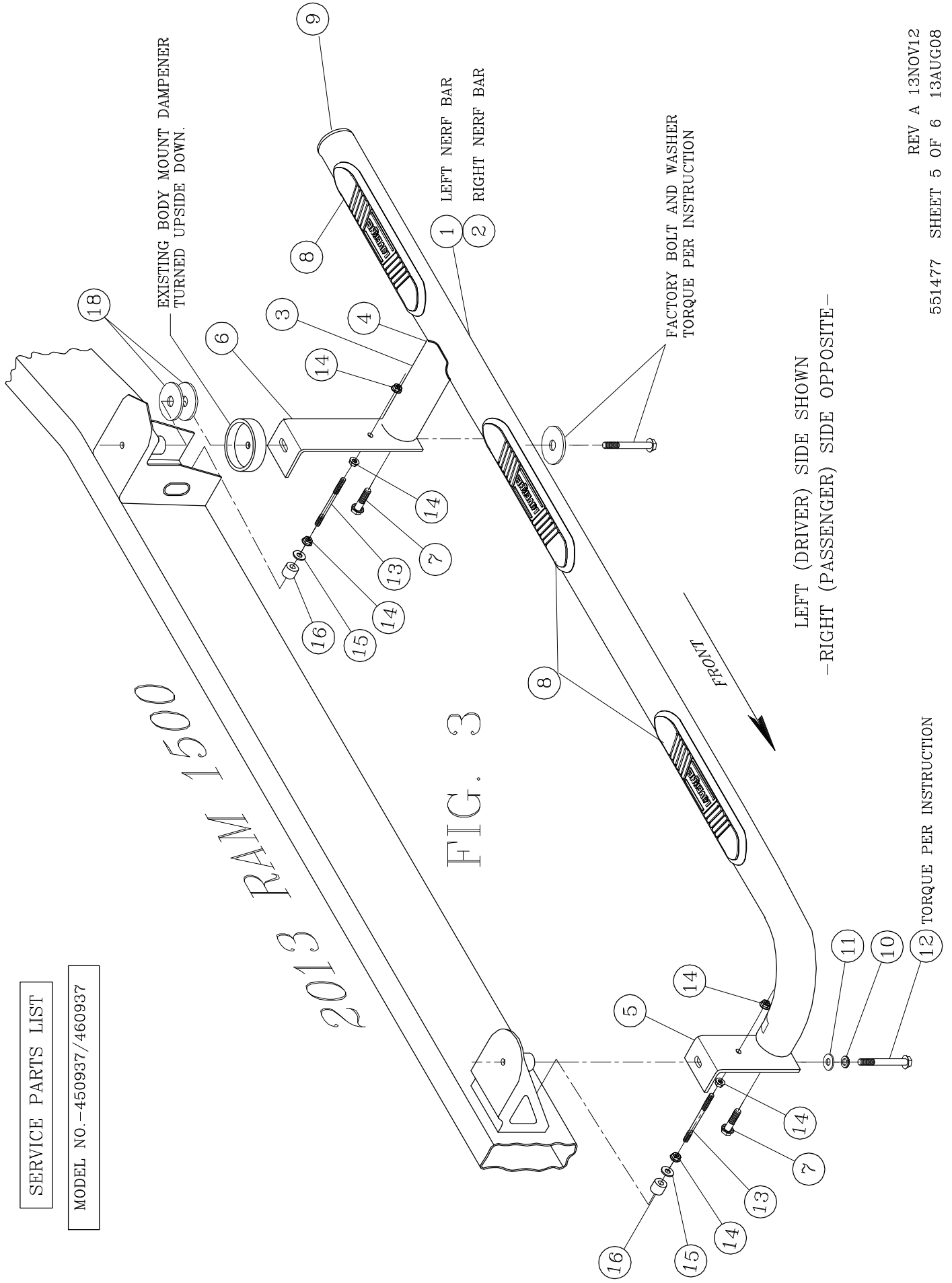

FIG. 3

LEFT (DRIVER) SIDE SHOWN  
-RIGHT (PASSENGER) SIDE OPPOSITE-

SERVICE PARTS LIST

MODEL NO. -450939/460939

2013 RAM 1500

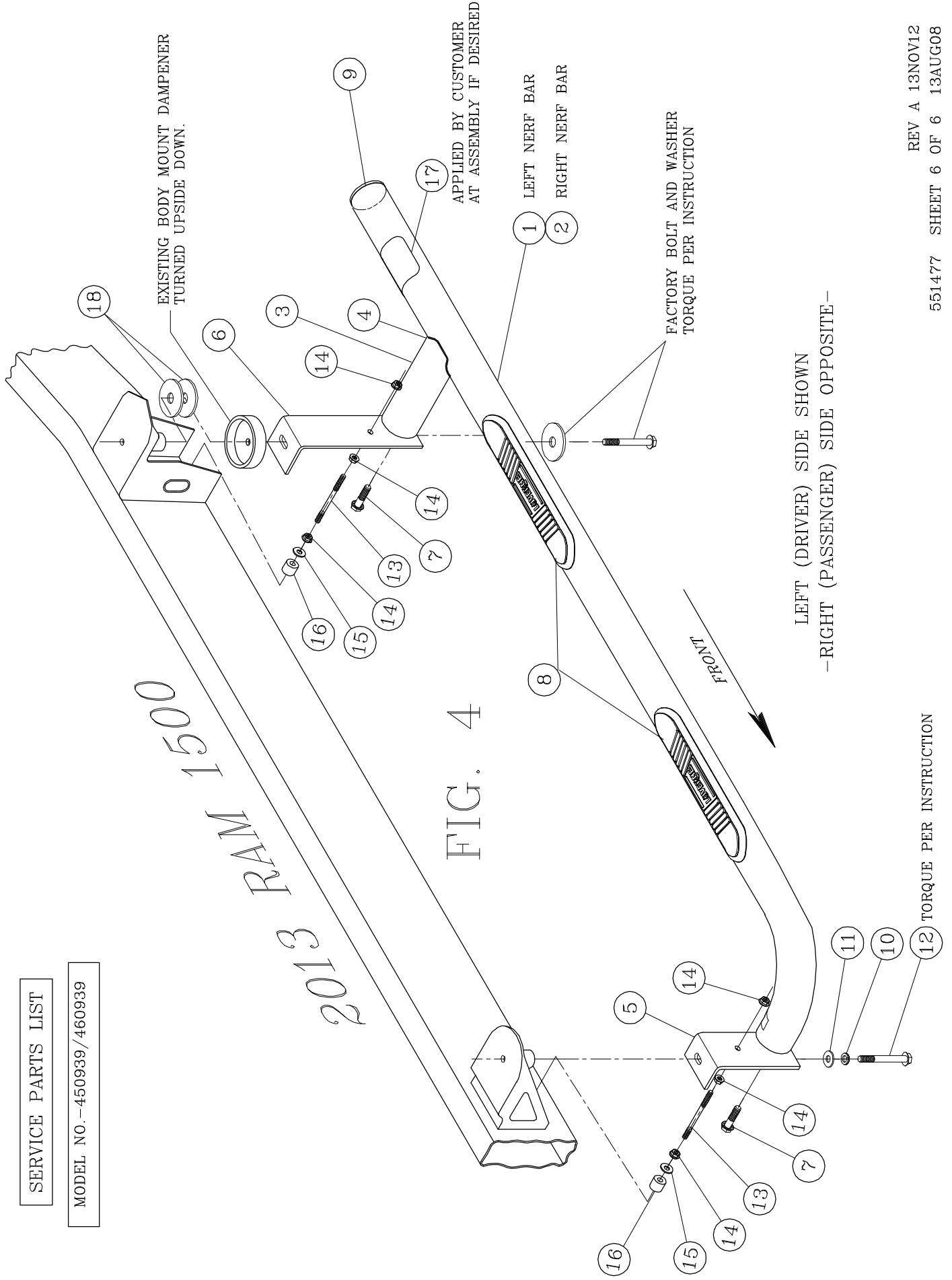

FIG. 4

LEFT (DRIVER) SIDE SHOWN  
-RIGHT (PASSENGER) SIDE OPPOSITE-