

# INSTALLATION INSTRUCTIONS AND PARTS LIST

APPLICATION: 450921/460921, 450922/460922, 450923/460923 NERF BARS ON:  
**2004 AND NEWER FORD F-150 REGULAR CAB, SUPER CAB**  
**2009 AND NEWER FORD F-150 SUPERCREW PICKUPS**



## NO DRILL INSTALLATION

1. READ INSTRUCTIONS COMPLETELY AND CHECK TO MAKE SURE THAT ALL REQUIRED PARTS (LISTED ON SERVICE PARTS LIST) ARE ON HAND BEFORE STARTING THE INSTALLATION.
2. THE NERF BARS (ITEMS #1 & #2) AND MOUNTING BRACKETS (ITEMS #3, #4, #5 & #6) ARE PRE-ASSEMBLED TO MATCH THE EXISTING MOUNTING LOCATIONS IN THE VEHICLE. IF ANY ADDITIONAL ADJUSTMENT SHOULD BE REQUIRED, THIS CAN BE ACCOMPLISHED BY LOOSENING THE PRE-TORQUED 1/2 IN. HEX HEAD BOLT THAT RETAINS THE FRONT AND REAR MOUNTING BRACKETS TO THE NERF BAR. IF THE PRE-TORQUE ON THIS 1/2 IN. BOLT IS BROKEN, THE BOLT MUST BE RE-TIGHTENED TO 65 LB. FT
3. EXISTING MOUNTING HOLE PATTERNS ARE LOCATED ON THE INTERIOR WALL AND PINCH WELD OF THE ROCKER PANEL. THESE MOUNTING HOLE PATTERNS MUST BE USED FOR THIS INSTALLATION PER THE FOLLOWING INSTRUCTIONS.
  - 3.1. THERE MAY BE A FACTORY TAPE COVERING THE MOUNTING HOLES. IF SO REMOVE THE TAPE TO INSTALL THE MULTI THREAD U-NUTS AS FOLLOWS. (THIS TAPE MUST BE RE-INSTALLED OVER THE ACCESS HOLES, LEAVING ONLY THE THREADS OF THE THREAD U-NUTS UNCOVERED).
  - 3.2. INSTALL 5/16" MULTI THREAD U-NUTS (ITEM #11) IN THE TOP TWO HOLES OF THE FRONT AND REAR INTERIOR WALL MOUNTING HOLE PATTERNS. INSTALL THESE NUTS SO THAT THE THREADS ARE TO THE INSIDE OF THE ROCKER PANEL. (INSERTING THE THREADED HALF OF THE U-NUT THRU THE ACCESS HOLE, AND SLIDING THE U-NUT TOWARDS THE MOUNTING HOLE UNTIL THE NUT SEATS IN THE HOLE DOES THIS).
4. INSTALL THE NERF BAR ASSEMBLY AS FOLLOWS:
  - 4.1. POSITION THE NERF BAR ASSEMBLY UP TO THE ROCKER PANEL SO THAT THE HOLES IN THE MOUNTING BRACKETS (ITEM #3-#5 OR #4-#6) MATCH THE U-NUTS IN THE HOLE PATTERNS LISTED ABOVE. (NOTE: THE BRACKET WITH THE OFFSET GOES TOWARD THE FRONT OF THE VEHICLE. FOR THE LEFT HAND FRONT BRACKET, POSITION THE BRAKE CABLE SO IT RESTS ON TOP OF THE BRACKET.)
  - 4.2. HANG THE NERF BAR ASSEMBLY ON THE UPPER BOLTS BY INSERTING 5/16" X 1.00" HEX HD SCREWS (ITEM #9) WITH FLAT WASHERS (ITEM #12) THROUGH THE HOLES IN THE BRACKET AND ROCKER PANEL INTO THE MULTI THREAD U-NUTS INSTALLED PER INSTRUCTION 3.2.
  - 4.3. INSTALL 5/16" X 1.00" HEX HEAD SCREWS (ITEM #9) WITH FLAT WASHERS (ITEM #12) UP THROUGH THE HOLES IN THE PINCH WELD AND THE FLANGES OF THE BRACKETS AND INSTALL 5/16" FLAT WASHERS (ITEM #12) AND 5/16"-18 SERRATED FLANGE NUTS (ITEM #10).
  - 4.4. TIGHTEN THE UPPER BOLTS.
  - 4.5. TIGHTEN THE LOWER BOLTS IN THE PINCH WELD. (TORQUE ALL 5/16" FASTENERS TO 19 LB. FT.).

## INSTALLATION INSTRUCTIONS AND PARTS LIST

APPLICATION: 450921/460921, 450922/460922, 450923/460923 NERF BARS ON:  
**2004 AND NEWER FORD F-150 REGULAR CAB, SUPER CAB**  
**2009 AND NEWER FORD F-150 SUPERCREW PICKUPS**

### SERVICE PARTS LIST

ITEM	PART NO.	QTY	DESCRIPTION
1	551212	1	NB WLDMT-LH, REGULAR CAB, 460921 (SST)
2	551213	1	NB WLDMT-RH, REGULAR CAB, 460921 (SST)
1	551214	1	NB WLDMT-LH, REGULAR CAB, 450921 (BLACK)
2	551215	1	NB WLDMT-RH, REGULAR CAB, 450921 (BLACK)
1	551216	1	NB WLDMT-LH, SUPER CAB, 460922 (SST)
2	551217	1	NB WLDMT-RH, SUPER CAB, 460922 (SST)
1	551218	1	NB WLDMT-LH, SUPER CAB, 450922 (BLACK)
2	551219	1	NB WLDMT-RH, SUPER CAB, 450922 (BLACK)
1	551446	1	NB WLDMT-LH, SUPERCREW, 460923 (SST)
2	551447	1	NB WLDMT-RH, SUPERCREW, 460923 (SST)
1	551448	1	NB WLDMT-LH, SUPERCREW, 450923 (BLACK)
2	551449	1	NB WLDMT-RH, SUPERCREW, 450923 (BLACK)
3	551455	1	MOUNTING BRKT-FRONT, LH
4	551457	1	MOUNTING BRKT-FRONT, RH
5	551201	1	MOUNTING BRKT-REAR, LH, REGULAR CAB
6	551203	1	MOUNTING BRKT-REAR, RH, REGULAR CAB
5	551459	1	MTG BRKT-REAR, LH, SUPER CAB/SUPERCREW
6	551461	1	MTG BRKT-REAR, RH, SUPER CAB/SUPERCREW
7	103950	4	PAD-STEP,NERF BAR,BLK,20"
8	104249	4	SCREW-HHC, SERR FLNG,1/2-13 X 2.00",ZP
9	100647	16	SCREW-HHC,5/16-18 X 1.00",ZP
10	100178	8	NUT-SERR FLANGE, 5/16"-18
11	104264	8	NUT-U MULTI THD, 5/16"-18 UNC
12	100034	24	WASHER-FLAT,5/16",ZP

SERVICE PARTS LIST

MODEL NO.- 450921/460921  
 450922/460922  
 450923/460923

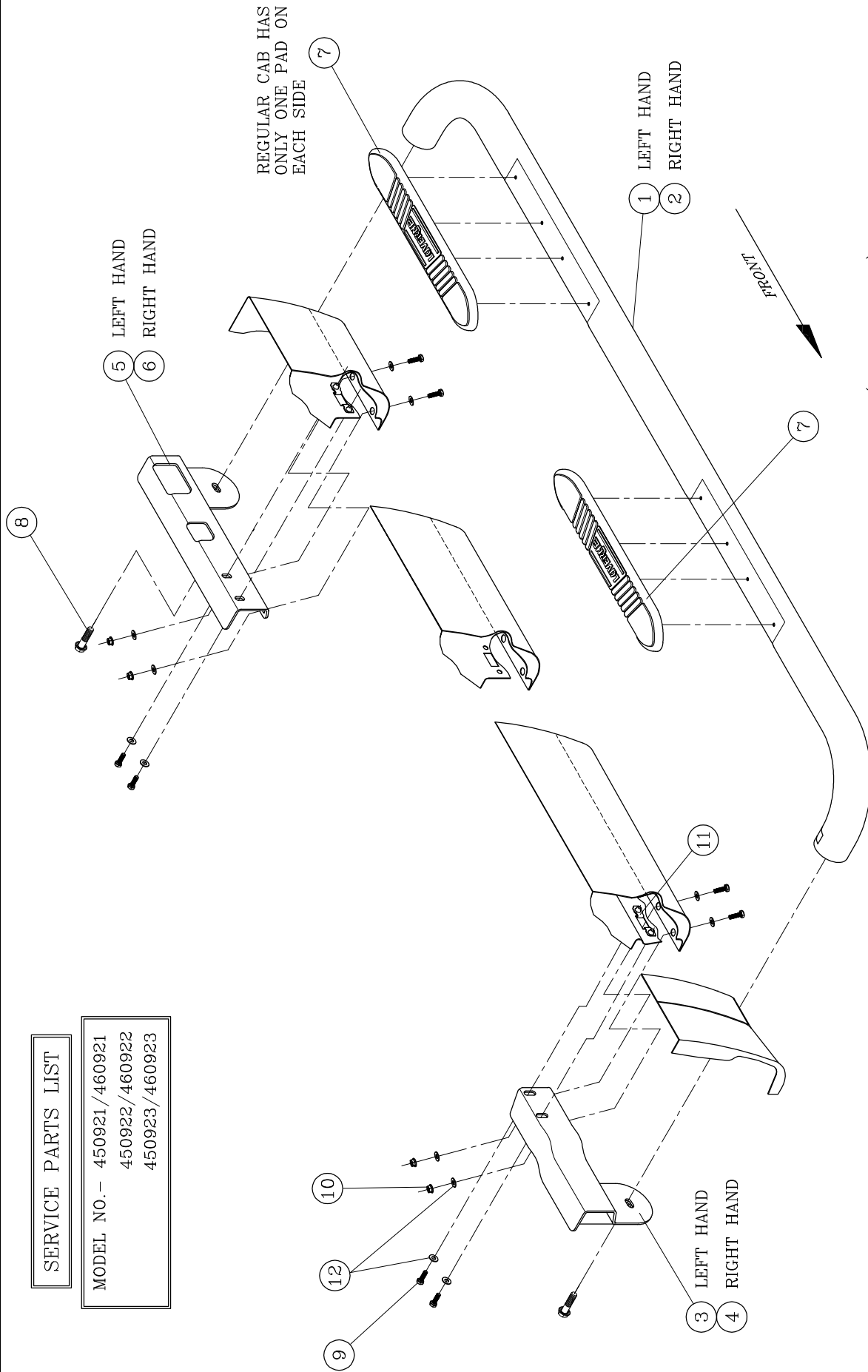

LEFT HAND (DRIVERS SIDE) SHOWN  
 RIGHT HAND (PASSENGERS SIDE) OPPOSITE

**LOVERNE**  
 TRUCK  
 EQUIPMENT  
 INC.  
 1700 Birch Street  
 Brandon, SD 57005