

INSTALLATION INSTRUCTIONS AND PARTS LIST

MODEL 415078, 415088, GRIP STEPS (BOARDS ONLY)

UNIVERSAL APPLICATIONS

1. Read instructions completely and check to make sure that all required parts (listed on the service parts list) are on hand before starting the installation.
2. Follow the instructions included with the specific bracket package that you are using to mount the brackets to your vehicle.
3. Step assembly:
 - 3.1 Before attaching the grip steps to the brackets, slide the appropriate number of support braces (item #2) into the channel of the step (item #1).
 - 3.2 Slide the end cap (item #3) over the front and rear of each step. Using the supplied #8 x 1/2" self drilling tek screw (item #8), screw the end cap to the bottom of the step.
4. Attaching the step to the mounting bracket:
 - 4.1 Set the step on the mounting brackets, and slide each support brace over the top of each mounting bracket. Attach the flat spacer plate (item #4) to the bottom of the step, between the support brace, and the top of the mounting bracket.
 - 4.2 Using the supplied 5/16-18 x 1" carriage bolt, washer, and flange nuts, (item #5, 6, 7), attach the step assembly, flat spacer plate and mounting bracket. **(NOTE: Some of the flange nuts are supplied in the specific bracket package, not the step package.)**
 - 4.3 Set the step plate in the correct position and tighten all fasteners.
Torque all 5/16" fasteners to 19 LB FT.

SERVICE PARTS LIST

ITEM	PART NO.	QTY	DESCRIPTION
1	551384	2	EXTRUSION-AL,77.62, GRIP STEP,BLK,415078
1	551385	2	EXTRUSION-AL,87.75,GRIP STEP,BLK,415088
2	551296	8	SUPPORT BRACE, UPPER, GALV
3	551394	4	CAP-END,GRIP STEP, BLACK, PLASTIC
4	551298	8	SPACER PLATE, LOWER, BLACK
5	108683	16	BOLT-CRG,5/16-18 X 1.0", SST
6	101369	16	WASHER-FLAT,5/16,SST
7	102680	16	NUT-SERR FLG,HX,SST,WX,5/16-18
8	107958	8	SCR-TEK #8-18 X 1/2",SST,BLK

LIVERNE
TRUCK EQUIPMENT

(A LIVERNE Company)

1200 E. Birch St.

Brandon, SD 57005

REV B 03DEC10

REV A 10JUL09

551267 SHEET 1 OF 2 20AUG08

SERVICE PARTS LIST

MODEL NO. - 415078
- 415088

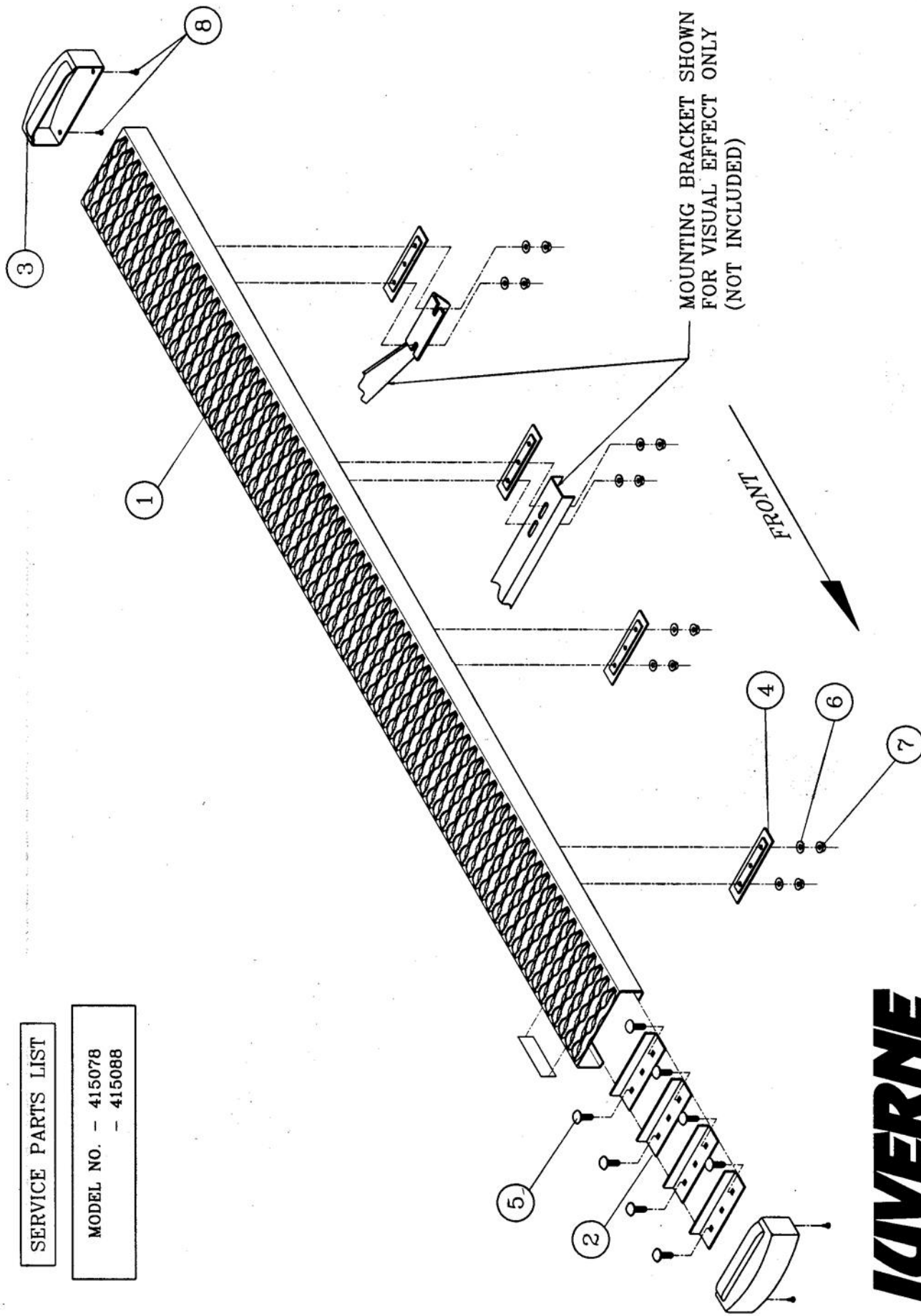

LAVERNE
TRUCK EQUIPMENT
(A LAVERNE Company)

1200 E. Birch St.
Brandon, SD 57005

REV B 03DEC10
REV A 10JUL09
551267 SHEET 3 20AUG08

INSTALLATION INSTRUCTIONS AND PARTS LIST

**APPLICATION:
MODEL 401124 GRIP STEPS:
2011 AND NEWER FORD EXPLORER**

1. READ INSTRUCTIONS COMPLETELY AND CHECK TO MAKE SURE THAT ALL REQUIRED PARTS (LISTED ON THE SERVICE PARTS LIST) ARE ON HAND BEFORE STARTING THE INSTALLATION.
2. ATTACH THE MOUNTING BRACKETS TO THE CAB OF THE VEHICLE AS FOLLOWS:
 - 2.1 ON THE DRIVERS SIDE MEASURE FROM THE PINCH WELD AT THE FRONT WHEEL WELL OPENING TO THE REAR OF VEHICLE AND PLACE A MARK AT 11 1/8", AND 64 5/8". THEN MEASURE UP FROM BOTTOM OF THE PINCH WELD 1/2", AT BOTH OF THOSE LOCATIONS THIS WILL GIVE YOU YOUR CENTER POINT FOR DRILLING, SEE (FIGURE 1).
 - 2.2 DRILL A PILOT HOLE AT BOTH THE FRONT AND REAR LOCATIONS, AND THEN DRILL AN 11/32" HOLE IN BOTH PLACES. **NOTE: PLACE A SCRAP PIECE OF METAL OR WOOD BETWEEN THE PLASTIC ROCKER, AND THE PINCH WELD TO AVOID DRILLING THROUGH THE PLASTIC WHEN DRILLING PINCH WELDS.**
 - 2.3 INSERT 5/8" CLIPPED HEAD BOLT (ITEM #4) INTO THE LARGE SLOT LOCATED ON THE ANGLED PORTION OF THE INNER ROCKER PANEL AT BOTH FRONT AND REAR LOCATIONS. SEE (FIGURE 2.) FOR SLOT LOCATIONS, SEE (FIGURE 3.) ON HOW TO INSERT CLIPPED HEAD BOLT INTO SLOT.
 - 2.4 PUSH 5/16" U-NUT (ITEM #11) ONTO PINCH WELD IN THE LOCATIONS THAT YOU DRILLED THE 11/32" HOLES. SEE (FIGURE 4.) FOR DETAILS ON HOW TO INSTALL.
 - 2.5 INSTALL FRONT MOUNTING BRACKET (ITEM #1) USING 5/8" FLAT WASHER, 5/8" LOCK WASHER, AND A 5/8" SERRATED FLANGE NUT (ITEMS #5,6,7) ONTO THE 5/8" CLIPPED HEAD BOLT (ITEM #4) PREVIOUSLY INSERTED INTO THE FRONT SLOT, LEAVE IT FINGER TIGHT. THEN INSERT THE 5/16"-18 X 1" SCREW (ITEM #8), THE 5/16" LOCK WASHER (ITEM#9), AND THE 5/16" FLAT WASHER (ITEM #10), THROUGH THE BRACKET AND INTO THE U-NUT, AND TIGHTEN TO 19 LB FT, THEN TIGHTEN 5/8"-11 UNC SERRATED FLANGE NUT (ITEM #7) TO 154 LB FT.
 - 2.6 INSTALL REAR BRACKET (ITEM#3) FOLLOWING THE PREVIOUS STEP (2.5).
 - 2.7 MEASURE FROM THE FRONT EDGE OF THE FRONT BRACKET BACK APPROXIMATELY 26 3/4" AND MAKE A MARK ON INNER ROCKER PANEL, THEN PLACE THE MIDDLE BRACKET (ITEM#2) UP IN THIS LOCATION AND TRACE THE 3 BOLT HOLES ONTO THE INNER ROCKER PANEL. **NOTE: MAKE SURE BRACKET IS STRAIGHT BEFORE MARKING HOLES.**
 - 2.8 DRILL A PILOT HOLE IN THE CENTER OF THOSE 3 LOCATIONS, AND THEN DRILL ALL 3 HOLES TO A 17/64" HOLE.
 - 2.9 INSTALL MIDDLE BRACKET (ITEM #2) USING 5/16"-18 X 1" SELF THREADING SCREWS (ITEM #12), AND 5/16" LOCK WASHERS (ITEM #9), IN ALL 3 HOLES IN BRACKET. TIGHTEN BOLTS TO 10 LB FT. **NOTE: DO TO THE THIN MATERIAL THESE BOLTS ARE THREADING INTO, IT IS VERY IMPORTANT NOT TO OVER TIGHTEN THESE 3 SCREWS, AS STRIPPING WILL OCCUR.**
 - 2.10 REPEAT STEPS 2.1 THRU 2.9 ON THE PASSENGER SIDE.
3. STEP ASSEMBLY:
 - 3.1 BEFORE ATTACHING THE GRIP STEPS TO THE BRACKETS, SLIDE THE APPROPRIATE NUMBER OF SUPPORT BRACES (ITEM #16) INTO THE CHANNEL OF THE STEP (ITEM #13).



- 3.2 SLIDE THE END CAP (ITEM #19) OVER THE FRONT AND REAR OF EACH STEP. USING THE SUPPLIED #8 X 1/2" SELF DRILLING TEK SCREW (ITEM #20), SCREW THE END CAP TO THE BOTTOM OF THE STEP.
4. ATTACHING THE STEP TO THE MOUNTING BRACKETS:
- 4.1 SET THE STEP ON THE MOUNTING BRACKETS, AND SLIDE EACH SUPPORT BRACE OVER TOP OF EACH MOUNTING BRACKET. ATTACH THE FLAT SPACER (ITEM #18) TO THE BOTTOM OF THE STEP, BETWEEN THE SUPPORT BRACE, AND THE TOP OF THE MOUNTING BRACKETS.
- 4.2 USING THE SUPPLIED 5/16-18 X 1" CARRIAGE BOLT, WASHER, AND FLANGE NUTS (ITEMS #16,15,14)
- 4.3 SET THE STEP PLATE IN THE CORRECT POSITION AND TIGHTEN ALL FASTENERS.
5. TORQUE ALL 5/16" FASTENERS TO 19 LB FT.

SERVICE PARTS LIST

ITEM	PART NO.	QTY	DESCRIPTION
1	551996	2	BRKT-MTG, R/L-FRONT, MEGA-STEP,571124
2	551994	2	BRKT-MTG, R/L-MIDDLE, MEGA-STEP,571124
3	551995	2	BRKT-MTG, R/L-REAR, MEGA-STEP,571124
4	104692	4	5/8"-11 UNC X 2" CLIPPED HEAD BOLT ZP
5	100147	4	5/8" FLAT WASHER ZP
6	100148	4	5/8" LOCK WASHER ZP
7	105643	4	5/8"-11 UNC SERRATED FLANGE NUT ZP
8	100647	4	5/16"-18 X 1" SCREW ZP
9	100030	10	5/16" LOCK WASHER ZP
10	100034	4	5/16" FLAT WASHER ZP
11	104264	4	5/16"-18 UNC U-NUT
12	109177	6	5/16"-18 X 1", SELF THREADING SCREW
INCLUDED IN BOARD PACKAGE			
13	551984	2	EXTRUSION-AL,72, GRIP STEP,BLK,415072
14	102680	12	5/16"-18 UNC SERRATED FLANGE NUT SST
15	101369	12	5/16" FLAT WASHER SST
16	108683	12	CARRIAGE BOLT 5/16-18 X 1" ZP
17	551296	6	GALVANIZED BRACE SUPPORT
18	551298	6	SPACER PLATE BLACK
19	551394	4	PLASTIC END CAP
20	107958	8	#8 X 1/2" PHILLIPS HEAD TEK SCREW



SERVICE PARTS LIST

MODEL NO. - 401124

Fig. 1

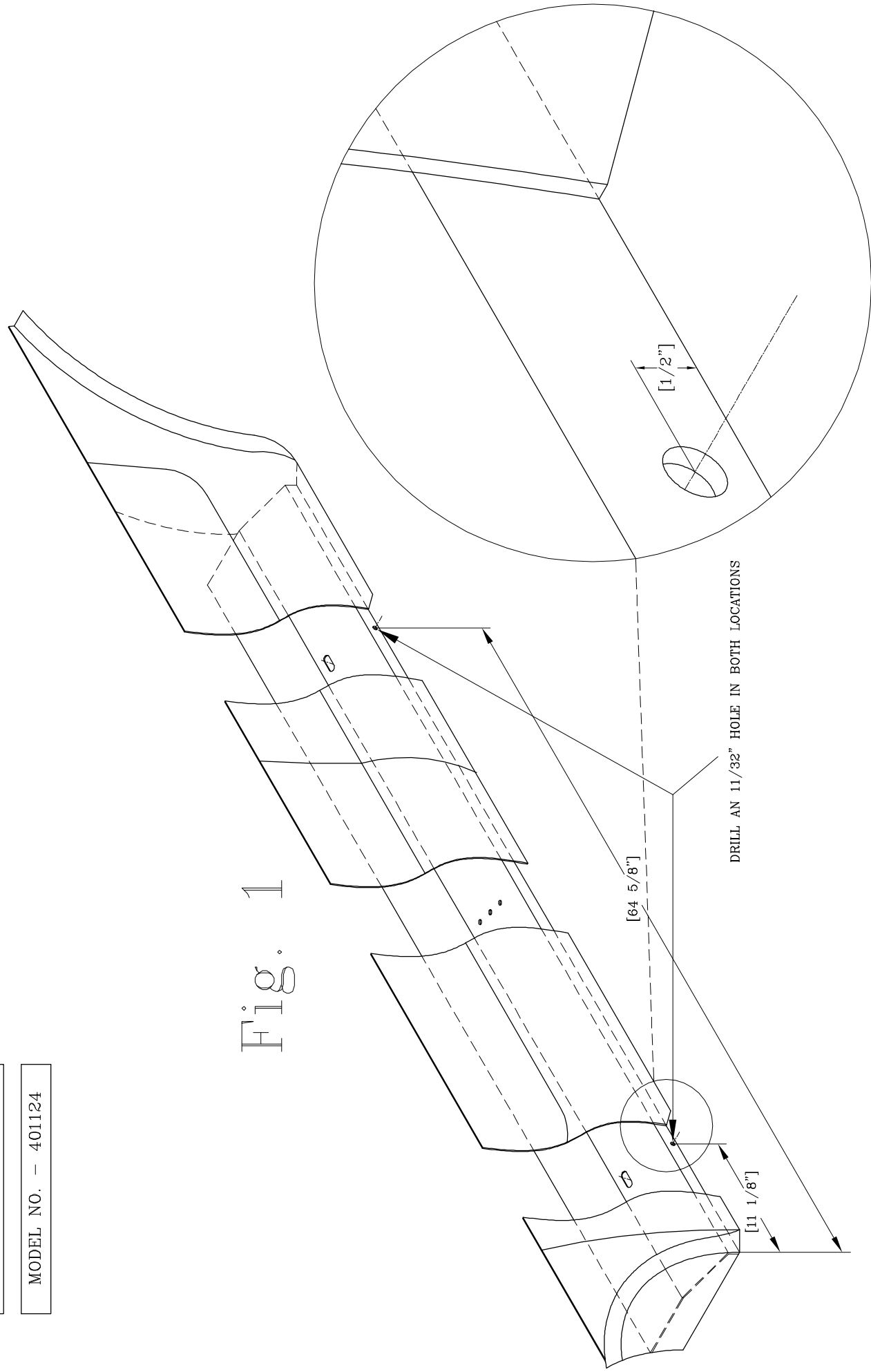

SERVICE PARTS LIST

MODEL NO. - 401124

Fig. 2

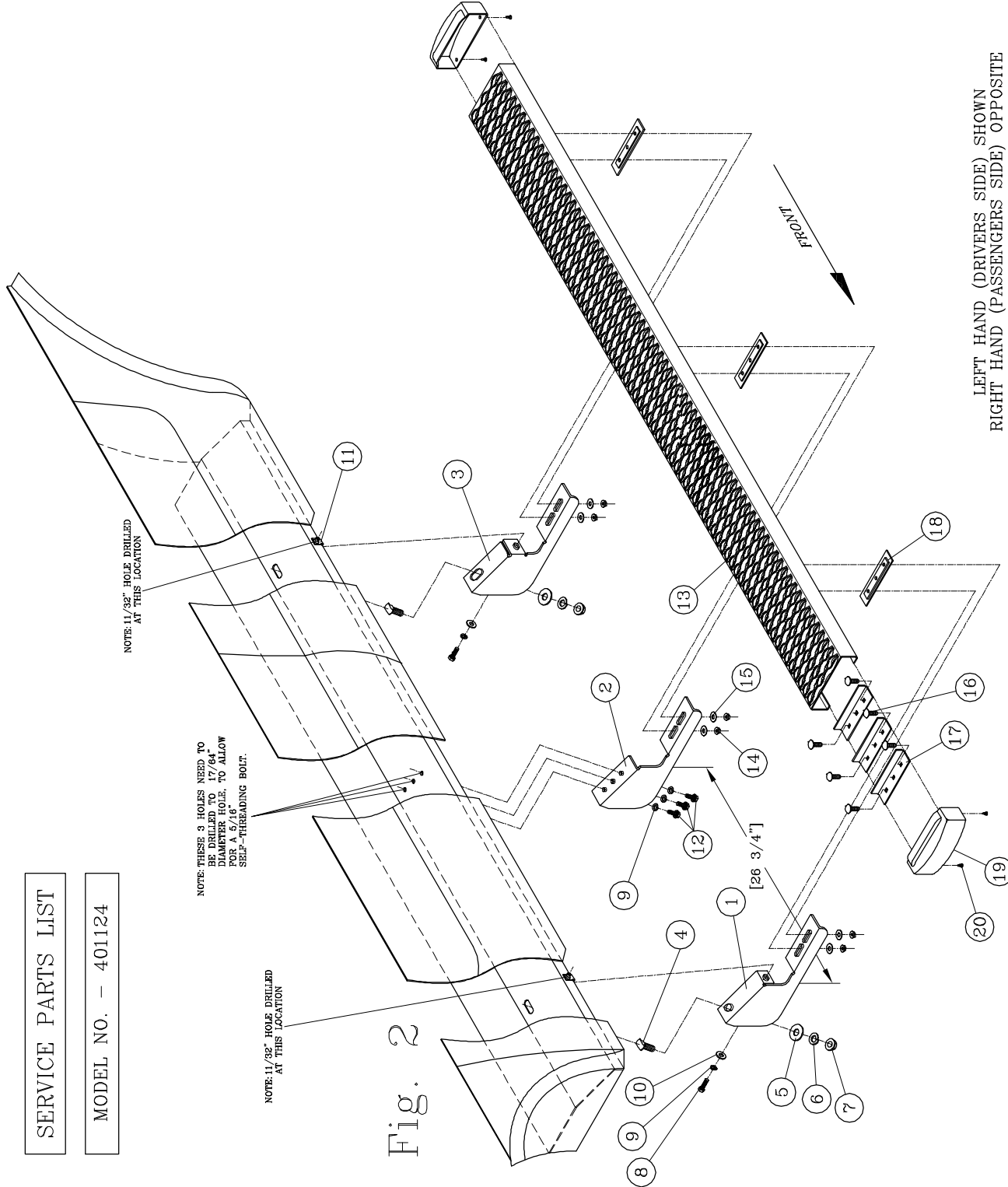

Fig. 3

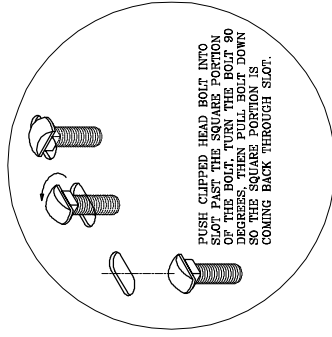
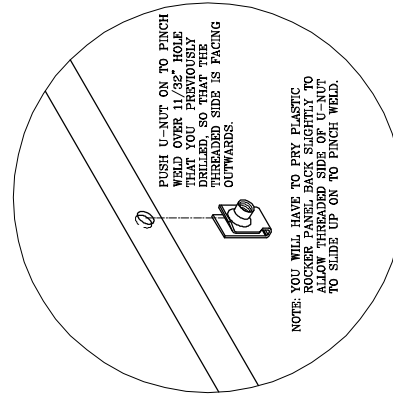

Fig. 4



LEFT HAND (DRIVERS SIDE) SHOWN
RIGHT HAND (PASSENGERS SIDE) OPPOSITE

NOTE: BOARD, AND MOUNTING HARDWARE ARE FOR VISUAL AID ONLY.