



INSTALLATION INSTRUCTIONS FOR MOUNTING

LUVERNE BULL BARS WITH THE FOLLOWING MODEL NOS.:
300220, 300260, 300320, 300360 – BULL BAR ASSEMBLY
300751 – BRACKET PACKAGE

2007 AND NEWER TOYOTA
TUNDRA PICKUPS

1. READ THE INSTRUCTIONS COMPLETELY AND CHECK TO MAKE SURE THAT ALL OF THE REQUIRED PARTS ARE ON HAND BEFORE STARTING THE INSTALLATION. THE CARTONS SHOULD CONTAIN:
 - (1) BULL BAR
 - (1) BRACKET PACKAGE:
 - (1) MOUNTING BRACKET, LH
 - (1) MOUNTING BRACKET, RH
 - (1) FASTENER PACKAGE
2. REMOVE THE RIGHT HAND FRONT TOW HOOK (YOU WILL NOT REINSTALL IT).
3. INSTALL THE RIGHT HAND MOUNTING BRACKET (ITEM #2) TO THE FRAME AS SHOWN IN FIG. 1 USING THE FACTORY TOW HOOK BOLTS AND THE SUPPLIED CLIPPED FLAT WASHER (ITEM #4). THE CLIPPED EDGE OF THE WASHER MUST BE TOWARD THE OUTBOARD SIDE OF THE VEHICLE (SEE FIG. 1). LEAVE THE BOLTS FINGER TIGHT AT THIS TIME.
4. REPEAT STEPS 2 & 3 ON THE LEFT HAND SIDE.

NOTE: BASED ON YOUR STATE AND LOCAL LAWS, DETERMINE IF YOU NEED TO RELOCATE YOUR LICENSE PLATE PRIOR TO STEP #5. REMOVE/RELOCATE/INSTALL YOUR LICENSE PLATE BRACKET AND LICENSE PLATE BEFORE MOUNTING THE BULL BAR TO YOUR VEHICLE (SEE FIG 1).

5. INSTALL THE BULL BAR TO THE MOUNTING BRACKETS. THE WELDED TABS ON THE BULL BAR FIT ON THE INBOARD SIDE OF THE MOUTING BRACKETS. FASTEN WITH THE 3/8-16 X 1-1/4 BOLTS (ITEM #5), 3/8" FLAT WASHERS (ITEM #6) (ONE ON THE BOLT SIDE, ONE ON THE NUT SIDE OF THE BRACKET), AND 3/8-16 SERRATED FLANGE NUTS (ITEM #7). ADJUST THE BULL BAR IN AND OUT AND UP AND DOWN AS NEEDED, THEN TIGHTEN THE FASTENERS.
6. TORQUE 3/8" BOLTS/NUTS TO 26 LB-FT.
7. TORQUE TOW HOOK BOLTS TO FACTORY SPECS.



(A LUVERNE Company)

1200 E. Birch St.

Brandon, SD 57005

REVA 20JAN16
305027 SHEET 1 OF 3 27OCT10

SERVICE PARTS LIST

ITEM	PART NO.	QTY	DESCRIPTION
1	300220	1	BULL BAR, 4" BOT MNT, SST,W/O SKD PL
1	300260	1	BULL BAR, 4" BOT MNT, BLK,W/O SKD PL
1	300320	1	BULL BAR, 3" BOT MNT, SST,W/O SKD PL
1	300360	1	BULL BAR, 3" BOT MNT, BLK,W/O SKD PL
2	305029	1	MOUNTING BRACKET, RH
3	305030	1	MOUNTING BRACKET, LH
4	103779	4	FLAT WASHER, CLIPPED, 1/2", ZP
5	100047	4	HEX HEAD SCREW, 3/8-16 X 1-1/4, ZP
6	100062	8	FLAT WASHER, 3/8", ZP
7	100181	4	SERRATED FLANGE NUT, 3/8-16, ZP
8	108023	4	HEX HEAD SCREW, SELF TAP, 1/4-20, ZP
9	100170	4	NUT, PLASTIC, SQUARE, 1/4", WHITE



(A LIVERNE Company)

1200 E. Birch St.

Brandon, SD 57005

REVA 20JAN16
305027 SHEET 2 OF 3 27OCT10

SERVICE PARTS LIST

MODEL NO. - 300751

fig. 1

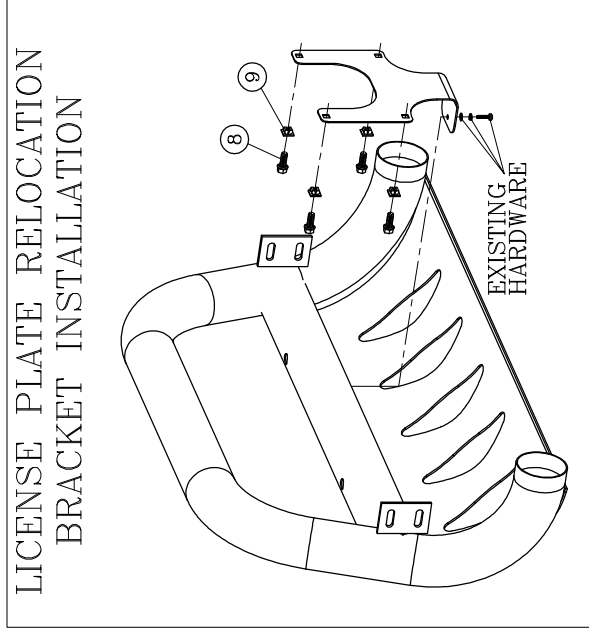
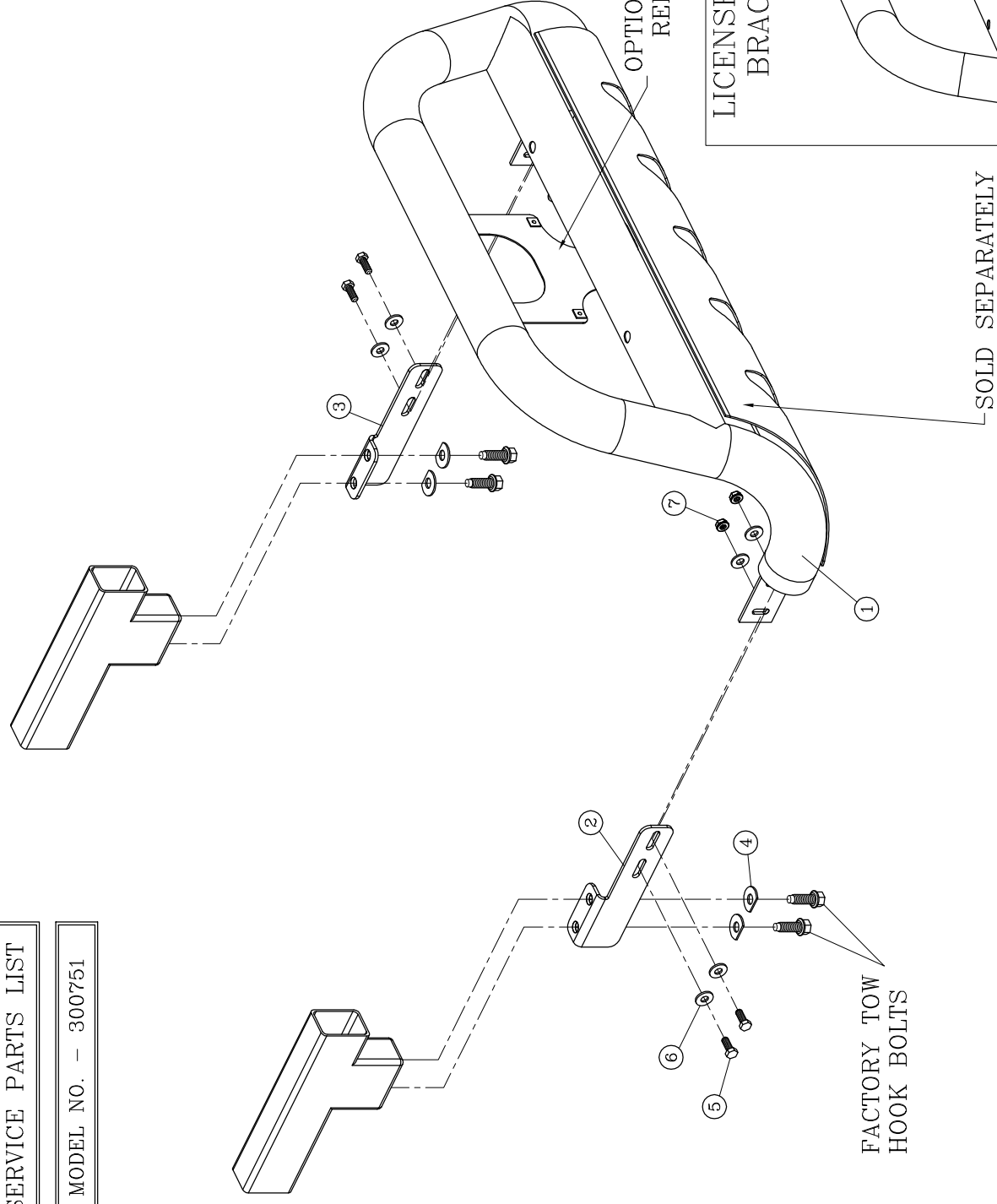
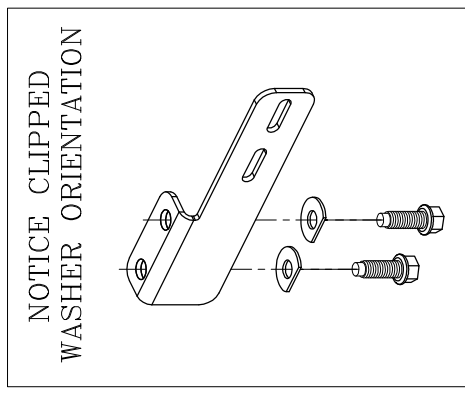

LIVERNE
ISO9001 QS9000 CERTIFIED TRUCK
EQUIPMENT
INC.
1200 Birch Street
Brandon, SD 57005