



## INSTALLATION INSTRUCTIONS FOR MOUNTING

LUVERNE BULL BARS WITH THE FOLLOWING MODEL NOS.:  
300220, 300260, 300320, 300360 – BULL BAR ASSEMBLY  
300931 – BRACKET PACKAGE

2009 AND NEWER DODGE  
RAM 1500 PICKUPS

1. READ THE INSTRUCTIONS COMPLETELY AND CHECK TO MAKE SURE THAT ALL OF THE REQUIRED PARTS ARE ON HAND BEFORE STARTING THE INSTALLATION. THE CARTONS SHOULD CONTAIN:
  - (1) BULL BAR
  - (1) BRACKET PACKAGE:
    - (1) MOUNTING BRACKET, LH
    - (1) MOUNTING BRACKET, RH
    - (2) MOUNTING BRACKET BRACE, LH/RH
    - (1) FASTENER PACKAGE
2. REMOVE THE FRONT AIR DAM. **BEFORE REINSTALLING IT YOU WILL NEED TO TRIM IT TO MAKE ROOM FOR THE BRACKETS.**
3. REMOVE THE RIGHT HAND FRONT TOW HOOK IF EQUIPPED (YOU WILL NOT REINSTALL IT).
4. REMOVE THE RIGHT HAND FACTORY BUMPER NUTS AND WASHERS (IF THE VEHICLE WAS EQUIPPED WITH TOW HOOKS, REMOVE THE 90 DEGREE TOW HOOK BRACKETS FROM THE BUMPER BOLTS AS WELL). DO NOT REMOVE THE BOLTS.
5. INSTALL THE RIGHT HAND MOUNTING BRACKET (ITEM #2) TO THE FRAME AS SHOWN IN FIG. 1 USING THE FACTORY BUMPER BOLTS, NUTS, AND WASHERS. LEAVE THE NUTS FINGER TIGHT AT THIS TIME.
6. INSTALL THE MOUNTING BRACKET BRACE (ITEM #4) TO THE REAR TOW HOOK HOLE AND TO THE MOUNTING BRACKET (ITEM #2) USING THE M12 X 1.5 X 35 BOLT (ITEM #8), 1/2" LOCK WASHER (ITEM #9), 7/16" FLAT WASHER (ITEM #10), 3/8-16 X 1-1/4 BOLT (ITEM #5), 3/8" FLAT WASHERS (ITEM #6), AND 3/8-16 SERRATED FLANGE NUT (ITEM #7). LEAVE THE BOLTS FINGER TIGHT AT THIS TIME.
7. REPEAT STEPS 3-6 ON THE LEFT HAND SIDE.

**NOTE: BASED ON YOUR STATE AND LOCAL LAWS, DETERMINE IF YOU NEED TO RELOCATE YOUR LICENSE PLATE PRIOR TO STEP #8. REMOVE/RELOCATE/INSTALL YOUR LICENSE PLATE BRACKET AND LICENSE PLATE BEFORE MOUNTING THE BULL BAR TO YOUR VEHICLE (SEE FIG 1).**



(A LUVERNE Company)

1200 E. Birch St.

Brandon, SD 57005

REVA 20JAN16  
305022 SHEET 1 OF 3 02NOV10

8. INSTALL THE BULL BAR TO THE MOUNTING BRACKETS. THE WELDED TABS ON THE BULL BAR FIT ON THE INBOARD SIDE OF THE MOUNTING BRACKETS. FASTEN WITH THE 3/8-16 X 1-1/4 BOLTS (ITEM #5), 3/8" FLAT WASHERS (ITEM #6) (ONE ON THE BOLT SIDE, ONE ON THE NUT SIDE OF THE BRACKET), AND 3/8-16 SERRATED FLANGE NUTS (ITEM #7). ADJUST THE BULL BAR IN AND OUT AND UP AND DOWN AS NEEDED, THEN TIGHTEN THE FASTENERS.
9. TORQUE 3/8" BOLTS/NUTS TO 26 LB-FT.
10. TORQUE M12 X 1.5 X 35 BOLTS TO 54 LB-FT.
11. TORQUE FACTORY BUMPER BOLTS TO FACTORY SPECS.
12. TRIM AND REINSTALL THE AIR DAM.

**SERVICE PARTS LIST**

ITEM	PART NO.	QTY	DESCRIPTION
1	300220	1	BULL BAR, 4" BOT MNT, SST,W/O SKD PL
1	300260	1	BULL BAR, 4" BOT MNT, BLK,W/O SKD PL
1	300320	1	BULL BAR, 3" BOT MNT, SST,W/O SKD PL
1	300360	1	BULL BAR, 3" BOT MNT, BLK,W/O SKD PL
2	305024	1	MOUNTING BRACKET, RH
3	305025	1	MOUNTING BRACKET, LH
4	305026	2	MOUNTING BRACKET BRACE, LH/RH
5	100047	6	HEX HEAD SCREW, 3/8-16 X 1-1/4, ZP
6	100062	12	FLAT WASHER, 3/8", ZP
7	100181	6	SERRATED FLANGE NUT, 3/8-16, ZP
8	100676	2	HEX HEAD SCREW, M12 X 1.5 X 35, ZP
9	100121	2	LOCK WASHER, 1/2", ZP
10	100081	2	FLAT WASHER, 7/16", ZP
11	108023	4	HEX HEAD SCREW, SELF TAP, 1/4-20, ZP
12	100170	4	NUT, PLASTIC, SQUARE, 1/4", WHITE



(A LIVERNE Company)

1200 E. Birch St.

Brandon, SD 57005

REVA 20JAN16  
305022 SHEET 2 OF 3 02NOV10

SERVICE PARTS LIST

MODEL NO. - 300931

fig. 1

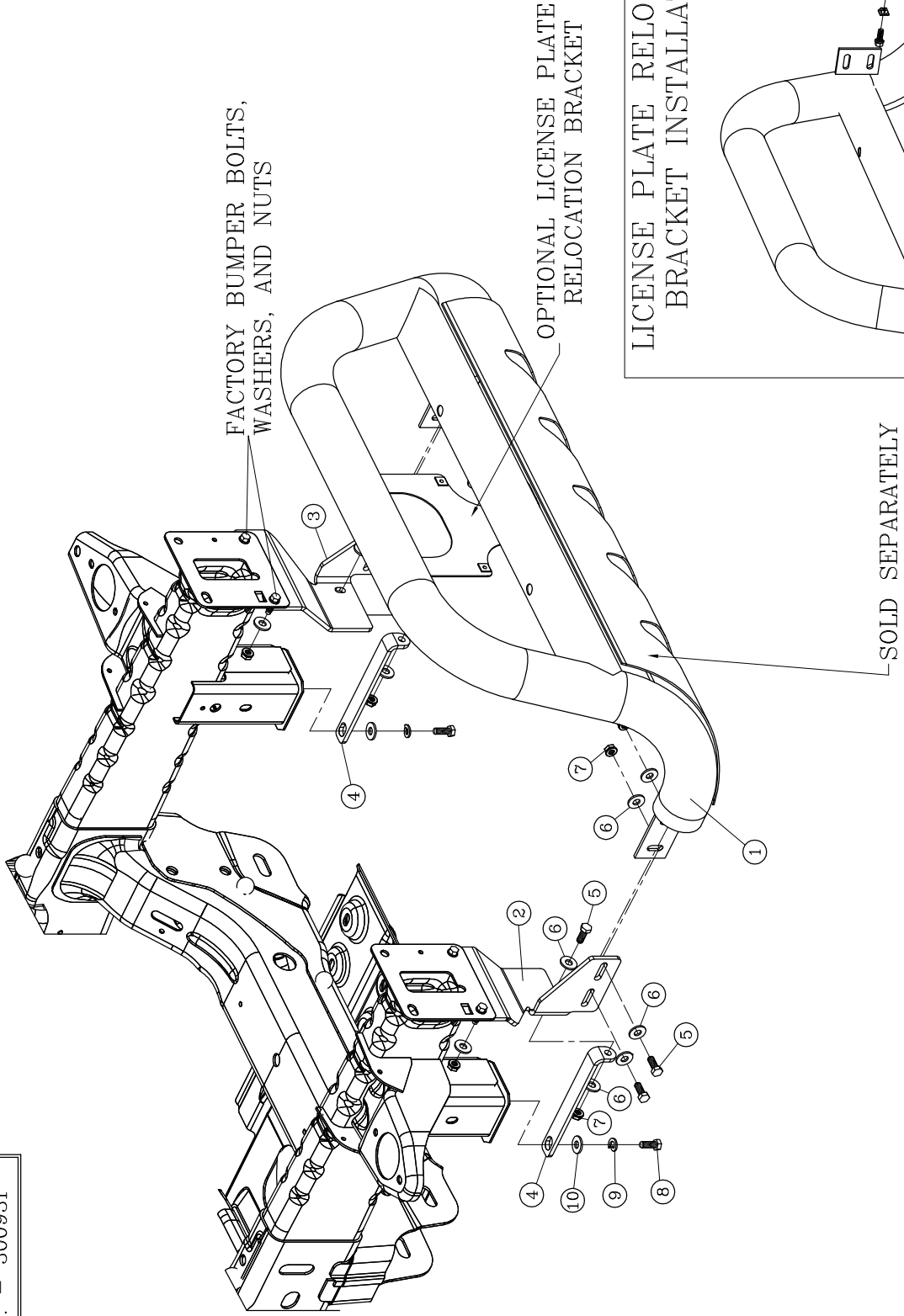

LICENSE PLATE RELOCATION  
BRACKET INSTALLATION

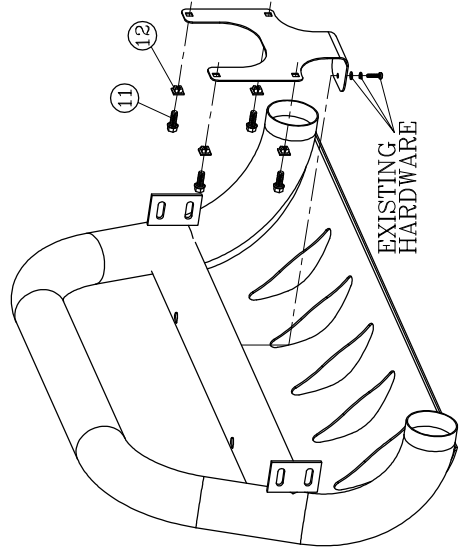

**LAMBERT**  
ISO9001 QS9000 CERTIFIED TRUCK  
EQUIPMENT  
INC.  
1200 Birch Street  
Brandon, SD 57005