



## INSTALLATION INSTRUCTIONS FOR MOUNTING

LUVERNE BULL BARS WITH THE FOLLOWING MODEL NO.  
300210, 300250, 300310, 300350 – BULL BAR ASSEMBLY  
301134 – BRACKET PACKAGE

2011 AND NEWER DODGE DURANGO  
2011 AND NEWER JEEP GRAND CHEROKEE

1. READ THE INSTRUCTIONS COMPLETELY AND CHECK TO MAKE SURE THAT ALL OF THE REQUIRED PARTS ARE ON HAND BEFORE STARTING THE INSTALLATION. THE CARTONS SHOULD CONTAIN:

- (1) BULL BAR
- (1) BRACKET PACKAGE:
  - (1) MOUNTING BRACKET, LH
  - (1) MOUNTING BRACKET, RH
  - (1) FASTENER PACKAGE

### **IF YOUR VEHICLE HAS TOW HOOKS:**

2. REMOVE THE 10MM SCREW ON THE RIGHT HAND FRONT INNER FENDER WELL, WHERE IT ATTACHES TO THE CENTER SPLASH GUARD, TO ALLOW ACCESS TO THE BACK OF THE TOW HOOK MOUNTING.
3. REMOVE THE RIGHT HAND FRONT TOW HOOK. (**NOTE: THESE WILL NOT BE REPLACED**).
4. INSTALL THE RIGHT HAND MOUNTING BRACKET (ITEM #2) TO THE FRONT OF THE FRAME AS SHOWN IN (FIGURE 1). USING THE SUPPLIED HARDWARE (ITEMS #4, #10, & #11). LEAVE THE BOLTS FINGER TIGHT AT THIS TIME.
5. REPEAT STEPS 2 THRU 4 ON THE LEFT HAND SIDE.

### **IF YOUR VEHICLE DOES NOT HAVE TOW HOOKS:**

2. REMOVE RIGHT ACCESS COVER IN FRONT AIR DAM BY REMOVING THE 2 PUSH FASTNERS, ON THE BACK SIDE OF AIR DAM (SEE FIGURE 2), USE A FLAT HEAD SCREW DRIVER ON FASTENER HEADS (SEE FIGURE 3).
3. REMOVE THE 10MM SCREW ON INNER FENDER WELL, WHERE IT ATTACHES TO THE CENTER SPLASH GUARD, TO ALLOW ACCESS TO THE REAR MOUNTING BOLT HOLE LOCATION.
4. INSTALL THE RIGHT HAND MOUNTING BRACKET (ITEM #2) TO THE FRONT OF THE FRAME AS SHOWN IN (FIGURE 1). USING THE SUPPLIED HARDWARE (ITEMS #4, #10, & #11). LEAVE THE BOLTS FINGER TIGHT AT THIS TIME.
5. REPEAT STEPS 2 THRU 4 ON THE LEFT HAND SIDE.



(A LUVERNE Company)

1200 E. Birch St.

Brandon, SD 57005

REVA 20JAN16  
305043 SHEET 1 OF 4 17AUG11

**NOTE: BASED ON YOUR STATE AND LOCAL LAWS, DETERMINE IF YOU NEED TO RELOCATE YOUR LICENSE PLATE PRIOR TO STEP #6. REMOVE/RELOCATE/INSTALL YOUR LICENSE PLATE BRACKET AND LICENSE PLATE BEFORE MOUNTING THE BULL BAR TO YOUR VEHICLE (SEE FIG 5).**

6. INSTALL THE BULL BAR TO THE MOUNTING BRACKETS. THE WELDED TABS ON THE BULL BAR FIT ON THE INBOARD SIDE OF THE MOUNTING BRACKETS. FASTEN WITH THE 3/8-16 X 1-1/4 BOLTS (ITEM #5), 3/8" FLAT WASHERS (ITEM #6, ONE ON THE BOLT SIDE, ONE ON THE NUT SIDE OF THE BRACKET), AND 3/8-16 SERRATED FLANGE NUTS (ITEM #7). ADJUST THE BULL BAR IN AND OUT, AND UP AND DOWN AS NEEDED, THEN TIGHTEN THE FASTENERS.
7. TORQUE ALL BOLTS/NUTS TO 26 LB-FT.

**SERVICE PARTS LIST**

ITEM	PART NO.	QTY	DESCRIPTION
1	300210	1	BULL BAR, 4" TOP MNT, SST,W/O SKD PL
1	300250	1	BULL BAR, 4" TOP MNT, BLK,W/O SKD PL
1	300310	1	BULL BAR, 3" TOP MNT, SST,W/O SKD PL
1	300350	1	BULL BAR, 3" TOP MNT, BLK,W/O SKD PL
2	305041	1	MOUNTING BRACKET, RH
3	305042	1	MOUNTING BRACKET, LH
4	101401	4	HEX HEAD SCREW M10 X 1.5 X 30, ZP
5	100047	4	HEX HEAD SCREW, 3/8-16 X 1-1/4, ZP
6	100062	8	FLAT WASHER, 3/8", ZP
7	100181	4	SERRATED FLANGE NUT, 3/8-16, ZP
8	108023	4	HEX HEAD SCREW, SELF TAP, 1/4-20, ZP
9	100170	4	NUT, PLASTIC, SQUARE, 1/4", WHITE
10	100081	4	FLAT WASHER, 7/16, ZP
11	100078	4	LOCK WASHER, 7/16, ZP



(A LIVERNE Company)

1200 E. Birch St.

Brandon, SD 57005

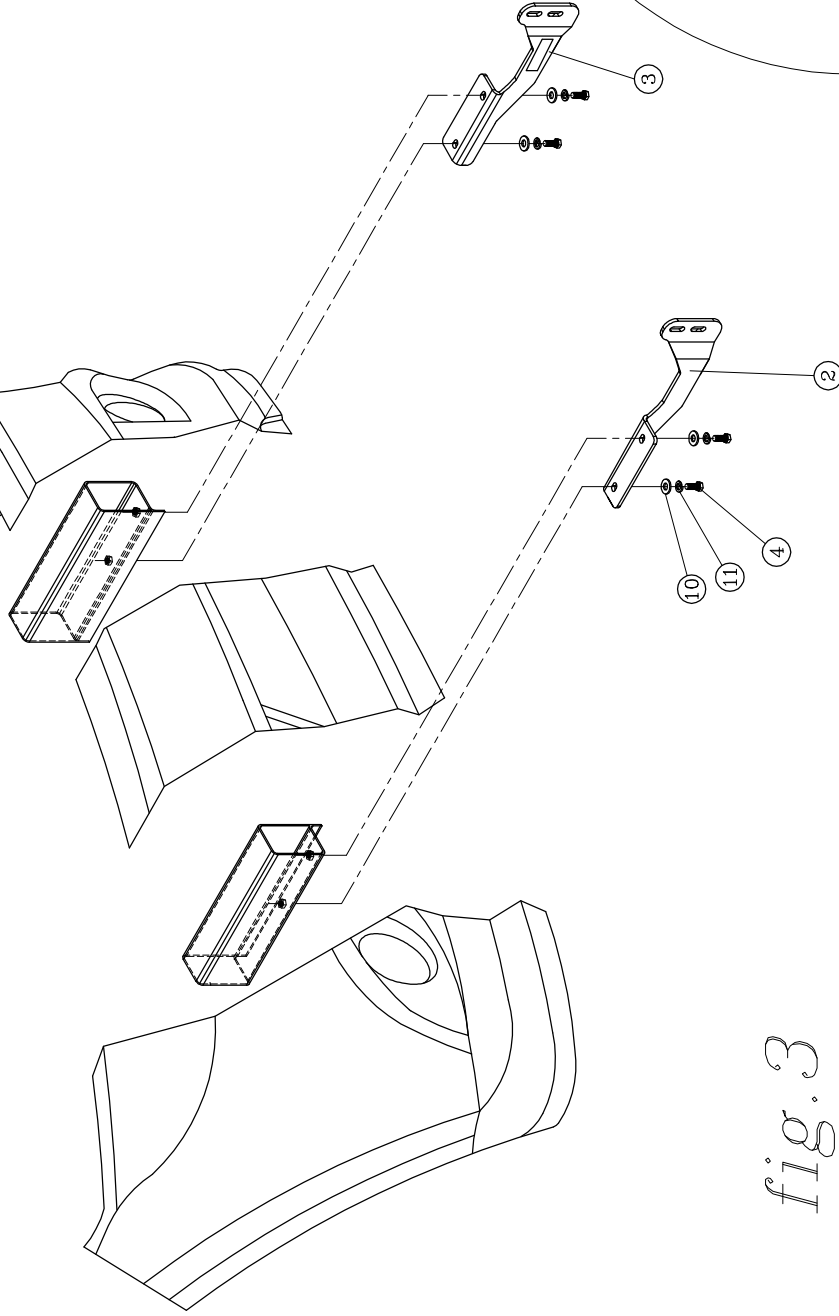
REVA 20JAN16

305043 SHEET 2 OF 4 17AUG11

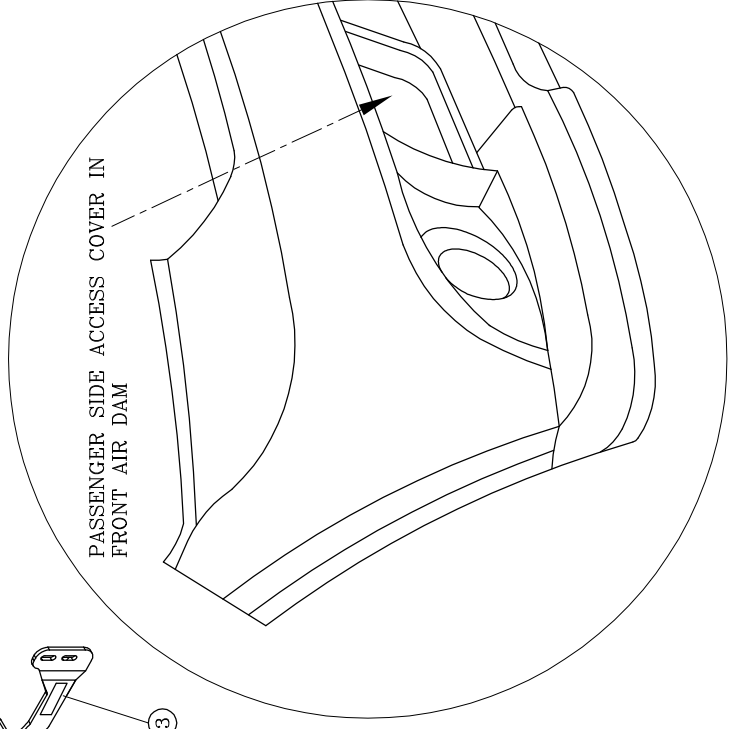
SERVICE PARTS LIST

MODEL NO. - 301134

*fig. 1*

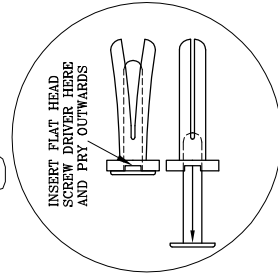


*fig. 2*



PASSENGER SIDE ACCESS COVER IN FRONT AIR DAM

*fig. 3*

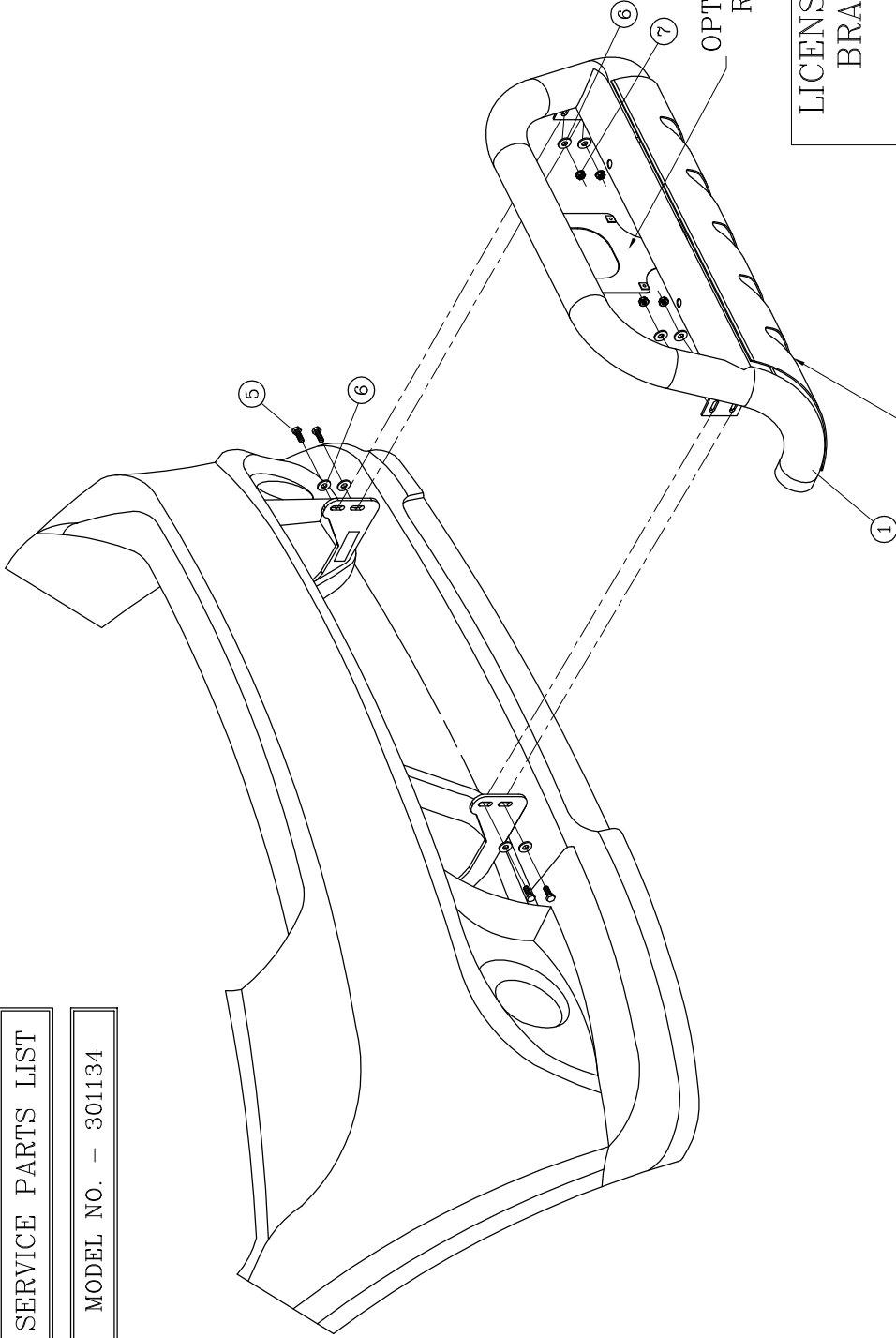


**LOVERNE**  
ISO9001 QS9000 CERTIFIED TRUCK  
EQUIPMENT  
INC.  
1700 Birch Street  
Brandon, SD 57005

SERVICE PARTS LIST

MODEL NO. - 301134

fig. 4



OPTIONAL LICENSE PLATE  
RELOCATION BRACKET

-SOLD SEPARATELY

LICENSE PLATE RELOCATION  
BRACKET INSTALLATION

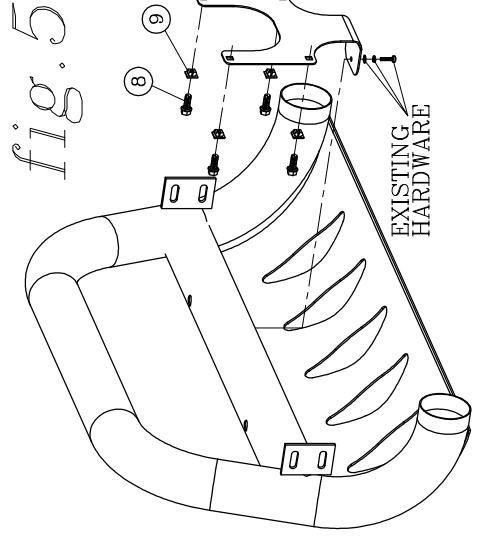


fig. 5