

# INSTALLATION INSTRUCTIONS

PART#: 241532/241532B

6" OVAL BENT SIDE BAR FOR DODGE RAM 1500 QUAD CAB 09-16

## PARTS LIST:

1	Driver/Left Sidebar	5	12mm Hex Nuts
1	Passenger/Right Sidebar	6	10-1.5mm x 35mm Hex Bolts
1	Driver/left Front Mounting Bracket	6	10mm x 27mm OD x 3mm Flat Washers
1	Driver/left Front Support Bracket	6	10mm Lock Washers
1	Passenger/right Front Mounting Bracket	7	8-1.25mm x 30mm Hex Bolts
1	Driver/left Center Mounting Bracket	12	8-1.25mm x 25mm Hex Bolts
1	Passenger/right Center Mounting Bracket	20	8mm x 24mm x 2mm Flat Washers
1	Driver/left Rear Mounting Bracket	18	8mm Lock Washers
1	Passenger/right Rear Mounting Bracket	1	8mm Nylon Lock Nut
6	12mm Plastic Retainers	2	6mm x 25mm Hex Bolt
6	12mm x 35mm Bolt x 10mm Nut Plates	4	6mm x 22mm x 2mm Flat washer
5	12mm x 32mm OD x 3mm Flat Washers	2	6mm Nylon Lock Nut
5	12mm Lock Washers		

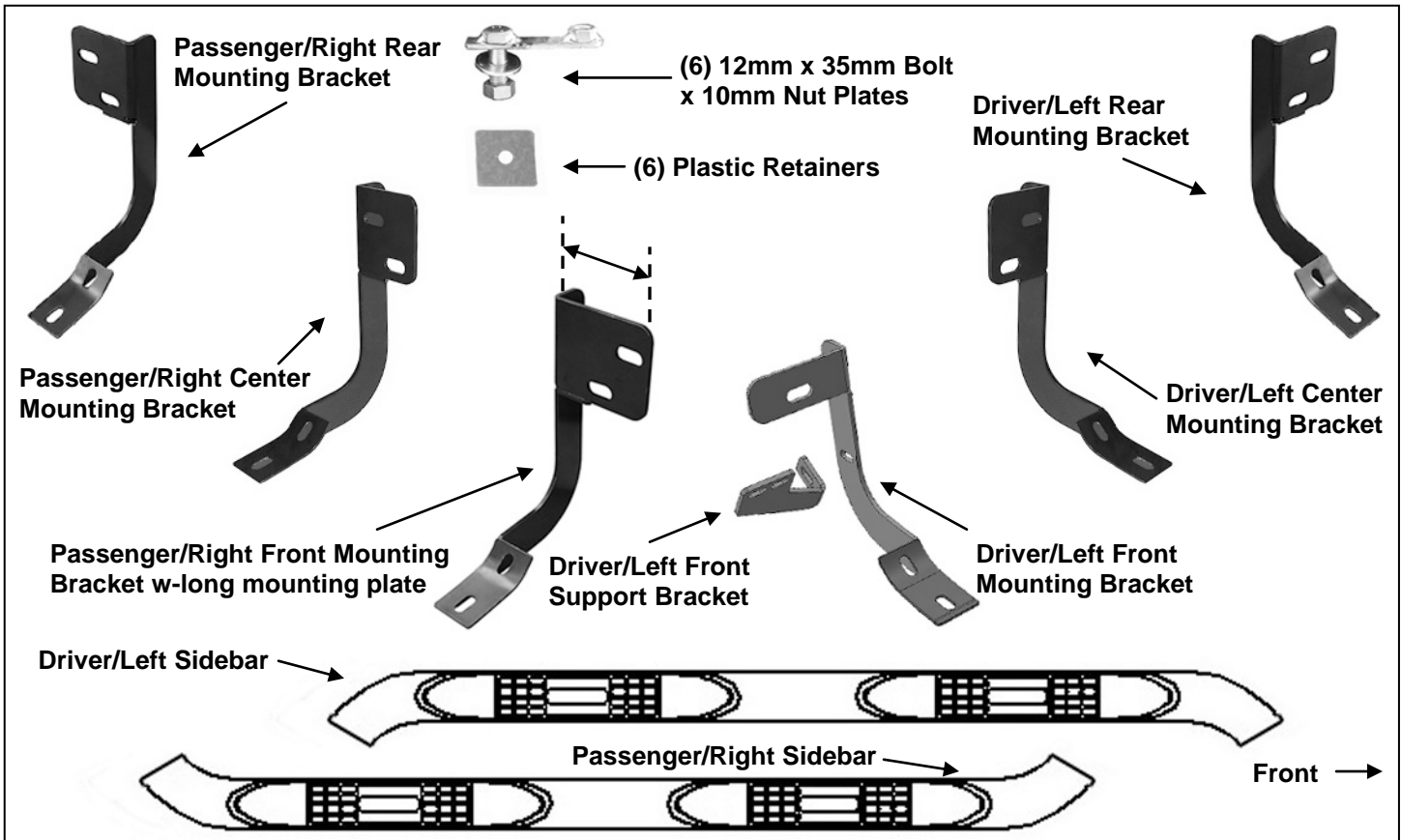

## PROCEDURE:

1. REMOVE CONTENTS FROM BOX. VERIFY ALL PARTS ARE PRESENT. READ INSTRUCTIONS CAREFULLY BEFORE STARTING INSTALLATION. DRILLING MAY BE REQUIRED.
2. Starting at the driver side-front of the vehicle, remove the sealing tape covering the factory holes in the side of the inner panel, (Figure 1).
3. Determine the correct procedure to attach the driver side front Bracket for your model/year:
 

**Models without factory threaded inserts in body panel:**

  - a. Partially thread a 12mm Plastic Retainer onto the threaded end of a 12mm Bolt and Nut Plate, (Figure 2). Insert the Bolt and Nut Plate into the oval hole and tighten the Plastic Retainer,

**(Figure 3). NOTE:** The Plastic Retainer is designed to keep the Bolt/Nut Plate from falling into the body panel and to aid in Bracket installation.

- b. Select the driver side front Mounting Bracket, **(Figure 5)**. Rotate the 12mm Bolt and Nut plate until the threaded nut lines up with the hole in the Mounting Bracket and body, **(Figure 3)**. Attach the Bracket to the threaded Nut Plate with (1) 10mm x 35mm Hex Bolt, (1) 10mm Lock Washer and (1) 10mm Flat Washer, **(Figures 5 & 7)**. Do not fully tighten hardware at this time.

**Models with factory threaded inserts:**

- a. Attach the driver side Front Bracket to the threaded insert with (1) 8mm x 30mm Hex Bolt, (1) 8mm Lock Washer and (1) 8mm Flat Washer, **(Figures 4, 5 & 7)**. Leave hardware loose.
4. Next, select the driver side front Support Bracket. Attach the Bracket to the back of the front Bracket with (1) 8mm x 30mm Hex Bolt, (2) 8mm Flat Washers and (1) 8mm Nylon Lock Nut, **(Figures 5 & 7)**. Rotate the Support Bracket to the back of the pinch weld. Line up the slot in the top of the Support Bracket with the (2) factory holes in the pinch weld. Attach the Bracket to the pinch weld with (2) 6mm Hex Bolts, (4) 6mm Flat Washers and (2) 6mm Nylon Lock Nuts, **(Figures 6 & 7)**. Do not fully tighten hardware at this time. **IMPORTANT:** 2009-10 models are not equipped with factory holes and will require drilling through the pinch weld to attach the Support Bracket. Do not drill through the pinch weld at this time, **(see Step 8)**.
5. Move along the side of the body panel to the center mounting location, **(Figure 8)**. Select (1) 12mm Bolt/Nut Plate. Repeat **Step 3** to install the Bolt/Nut Plate. Select the driver side center Bracket. Attach the Bracket to the Bolt/Nut Plate with (1) 12mm Flat Washer, (1) 12mm Lock Washer and (1) 12mm Hex Nut, **(Figure 9)**. Do not tighten hardware at this time. Line up the remaining hole in the Bracket with the hole in the inner body panel. Rotate the Bolt and Nut Plate until the threaded end (Nut) lines up with the hole in the Bracket. Secure with (1) 10mm x 35mm Hex Bolt, (1) 10mm Lock Washer and (1) 10mm Flat Washer, **(Figures 9 & 10)**.
  - a. **IMPORTANT NOTE:** Models with threaded insert, attach the Bracket to the threaded insert with (1) 8mm x 30mm Hex Bolt, (1) 8mm Lock Washer and (1) 8mm Flat Washer. The 10mm hardware will not be required **(Step 5)**. Snug but do not tighten hardware.
6. Move to the rear location, **(Figure 11)**. Repeat **Step 5** to install the rear Mounting Bracket, **(Figures 12 & 13)**. **IMPORTANT:** The rear Mounting Brackets, **(Figure 12)**, are slightly different than the front and center brackets, (see illustration on Page 1-note bolt pattern on mounting plate).
7. Once all of the driver side Brackets have been installed, carefully position the driver Sidebar onto the (3) Mounting Brackets. Attach the Sidebar to the cradles on the Mounting Brackets with the included (6) 8mm x 25mm Hex Bolts, (6) 8mm Lock Washers, and (6) 8mm Flat Washers, **(Figure 13)**. Do not tighten hardware at this time. **IMPORTANT:** If you are having any difficulty with installation, check Mounting Bracket location first. Use the illustration on **Page 1** to identify the Mounting Brackets.
8. Properly level and adjust the Sidebar and fully tighten all hardware.

**2009-10 models requiring drilling for driver side front Support Bracket:**

  - a. Make sure the Sidebar is level to the vehicle. Line up the slot on the Support Bracket with the back of the pinch weld. Mark the location of the slots onto the pinch weld.
  - b. Drill (2) 1/4" holes through the pinch weld. **IMPORTANT:** Do not drill too close to the bottom edge of the pinch weld. Drill the holes toward the outside of the marked slot.
  - c. Attach the Support Bracket to the pinch weld with (2) 6mm Hex Bolts, (4) 6mm Flat Washers and (2) 6mm Nylon Lock Nuts, **(Figures 6 & 7)**. Check for level then fully tighten all hardware.
9. Move to the passenger side of the vehicle. Remove tape covering front, center and rear locations. Repeat **Steps 5—7** for passenger side Mounting Bracket installation, **(Figures 14 & 15)**. **NOTE:** Refer to the illustration on **Page 1** to identify the correct Mounting Bracket for each of the remaining locations.
10. Do periodic inspections to the installation to make sure that all hardware is secure and tight.

**To protect your investment,** wax this product after installing. Regular waxing is recommended to add a protective layer over the finish. Do not use any type of polish or wax that may contain abrasives that could damage the finish.

**For stainless steel:** Aluminum polish may be used to polish small scratches and scuffs on the finish. Mild soap may be used also to clean the Sidebar.

**For gloss black finishes:** Mild soap may be used to clean the Sidebar.

### Driver Side Installation Pictured

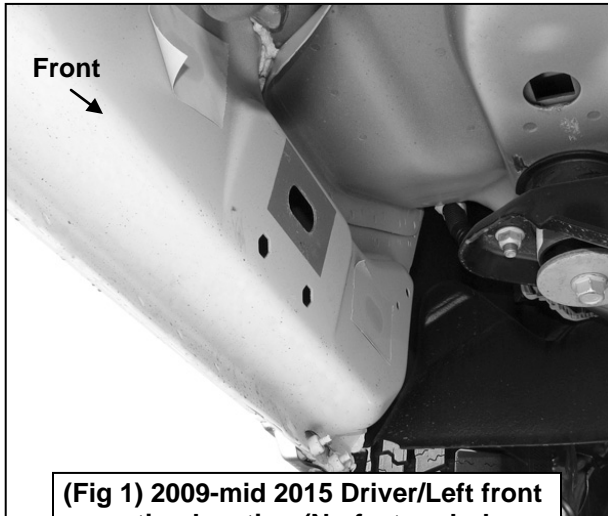

(Fig 1) 2009-mid 2015 Driver/Left front mounting location (No factory holes in pinch weld 2009-2011 models)



(Fig 2) 12mm Bolt-10mm Nut Plate w-Retainer, NOTE: 10mm hardware not required on models with threaded inserts

Rotate Bolt/Nut Plate to line up correct threaded hole with body panel and hole in Mounting Bracket (see arrow)

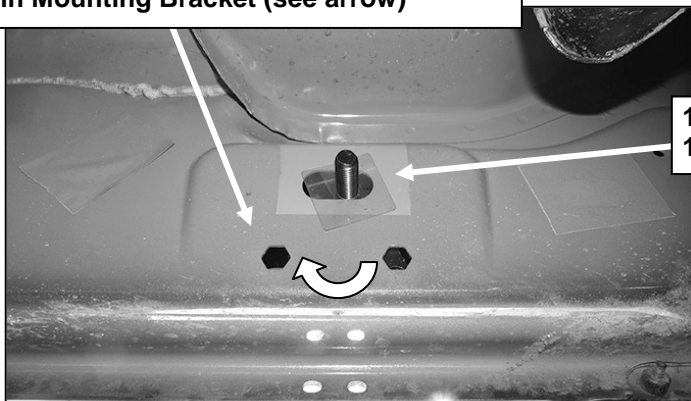

12mm x 35mm Bolt/10mm Nut Plate  
12mm Plastic Retainer

(Fig 3) Driver side front 2011-mid 2015.  
NOTE no threaded insert in body panel

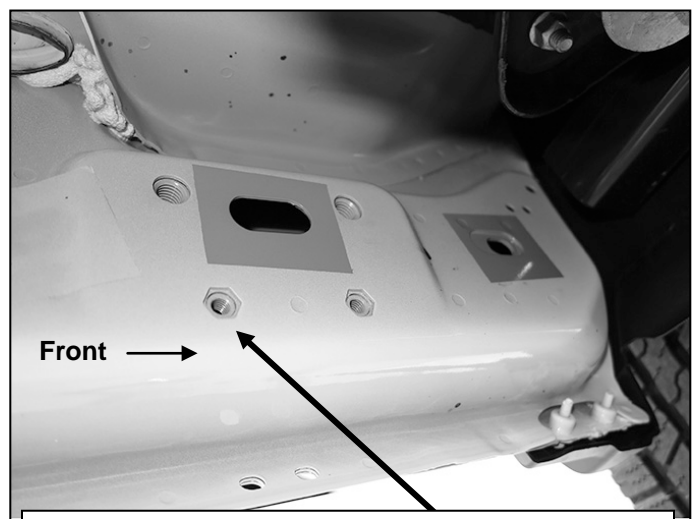

(Fig 4) Driver side front mid 2015-on, example of all models with factory installed threaded inserts

**Driver Side Installation Pictured**

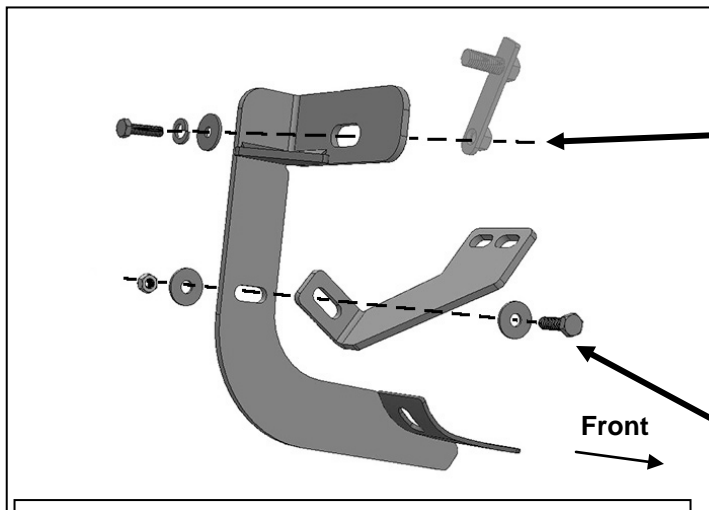

**(Fig 5) Driver/Left front Mounting Bracket assembly**

**Models without threaded insert using Bolt/Nut Plate, use:**  
 10mm x 35mm Hex Bolt  
 10mm Lock Washer  
 10mm Flat Washer

**Models with threaded insert use:**  
 8mm x 30mm Hex Bolt  
 8mm Lock Washer  
 8mm Flat Washer

8mm x 30mm Hex Bolt  
 (2) 8mm Flat Washers  
 8mm Nylon Lock Nut

(2) 6mm Hex Bolt  
 (4) 6mm Flat Washers  
 (2) 6mm Nylon Lock Nut

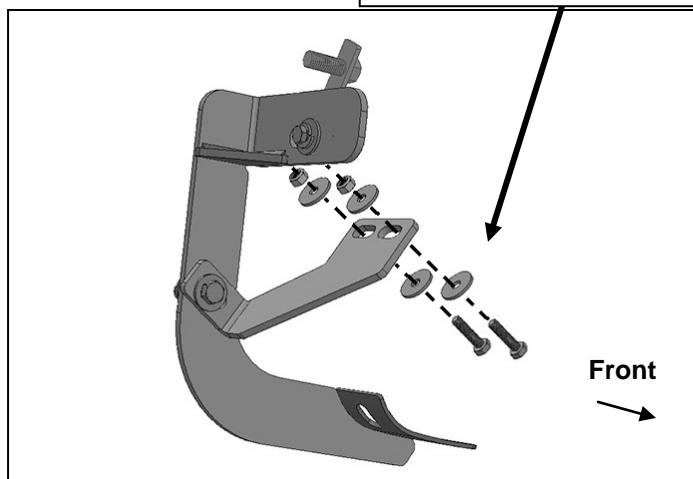

**(Fig 6) Attach Support Bracket to back of pinch weld**

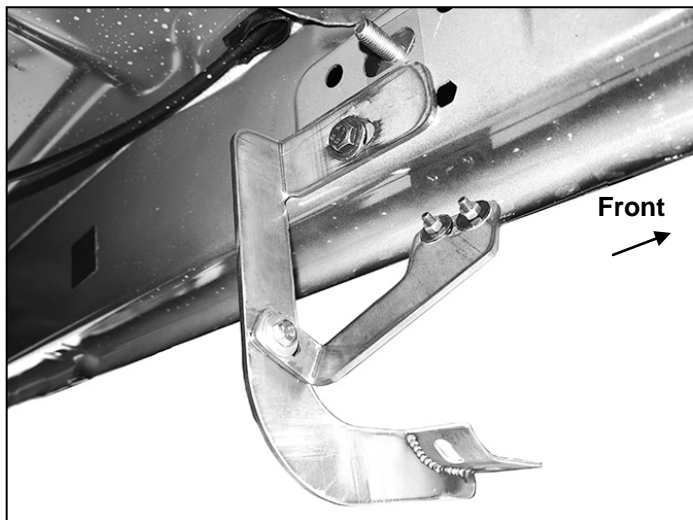

**(Fig 7) Driver side 2011-on model with factory holes in pinch weld pictured.**

**IMPORTANT: 2009-2010 models without holes in pinch weld will require drilling 1/4" holes through pinch weld to attach driver side front support bracket. Do complete installation of sidebars first, level sidebar before drilling holes for support bracket.**

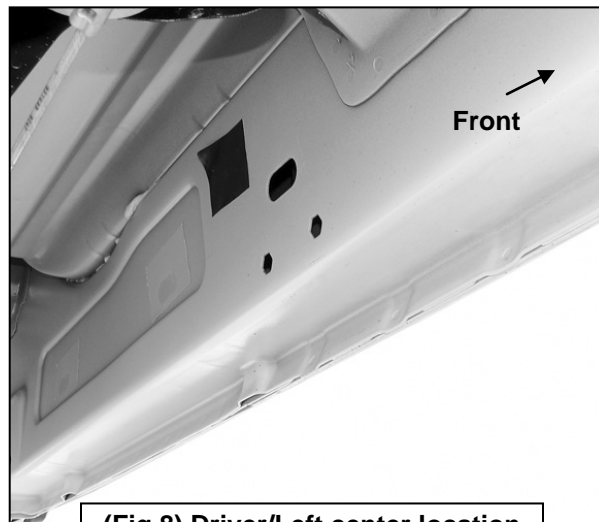

**(Fig 8) Driver/Left center location**

### Driver Side Installation Pictured



(Fig 9) Driver/Left center Bracket

12mm Flat Washer  
12mm Lock Washer  
12mm Hex Nut

Models without threaded insert using Bolt/Nut Plate, use:  
10mm x 35mm Hex Bolt  
10mm Lock Washer  
10mm Flat Washer

Models with threaded insert use:  
8mm x 30mm Hex Bolt  
8mm Lock Washer  
8mm Flat Washer

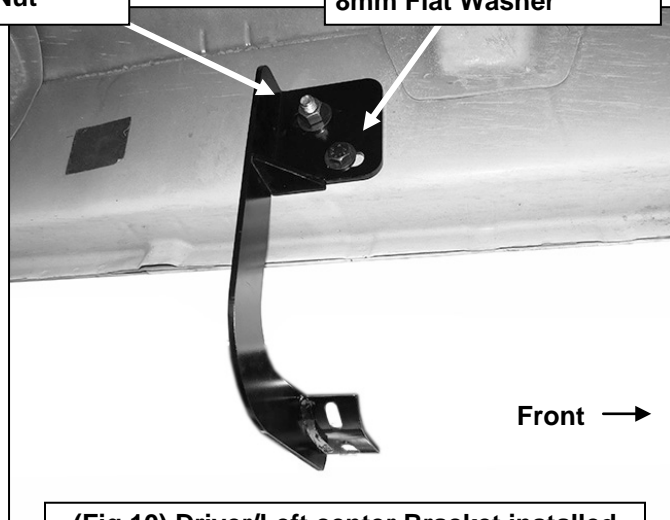

(Fig 10) Driver/Left center Bracket installed



(Fig 11) Driver/Left rear location

**IMPORTANT:** The Mounting Brackets look similar but each bracket is unique. Pay close attention to the bolt pattern on the mounting plate and direction of the cradle for the sidebar.

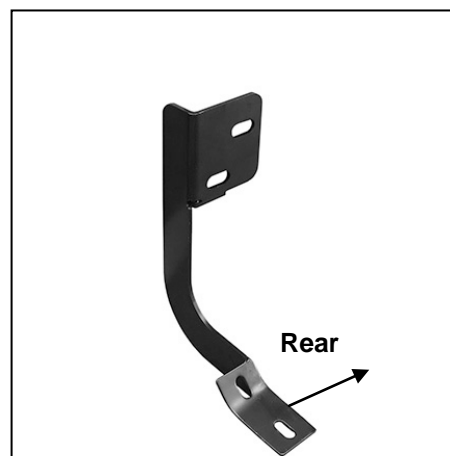

(Fig 12) Driver/Left rear Bracket

12mm Flat Washer  
12mm Lock Washer  
12mm Hex Nut

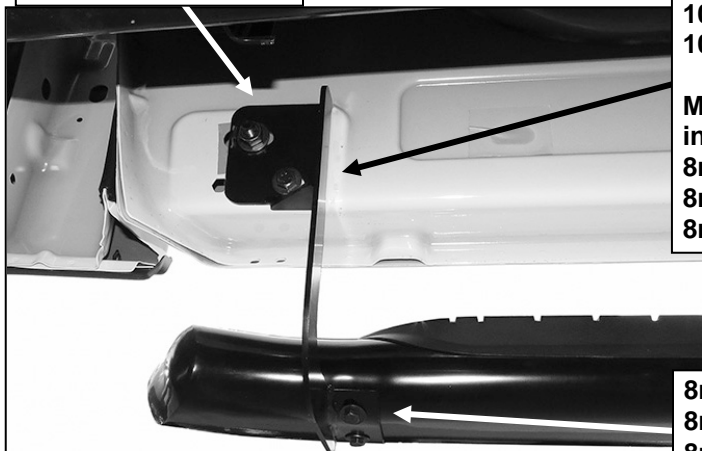

Models without threaded  
insert using Bolt/Nut  
Plate, use:  
10mm x 35mm Hex Bolt  
10mm Lock Washer  
10mm Flat Washer

Models with threaded  
insert use:  
8mm x 30mm Hex Bolt  
8mm Lock Washer  
8mm Flat Washer

8mm x 25mm Hex Bolts  
8mm Flat Washers  
8mm Lock Washers

(Fig 13) Driver/Left rear Mounting Bracket

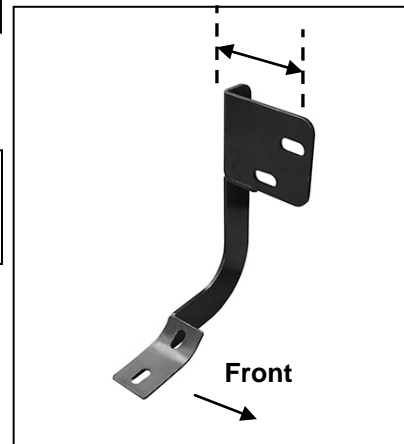

(Fig 14) Passenger/right front  
Bracket. NOTE: Bracket  
features longer mounting plate



8mm x 25mm Hex Bolts  
8mm Flat Washers  
8mm Lock Washers

(Fig 15) Passenger/right front Bracket installed



Complete Installation