

INSTALLATION MANUAL

3500255

Level of Difficulty

Easy

Installation difficulty levels are based on time and effort involved and may vary depending on the installer level of expertise, condition of the vehicle and proper tools and equipment.

Parts List

Qty	Description
1	Driver / left front hinge cover
1	Passenger / right front hinge cover
1	Driver / left rear hinge cover
1	Passenger / right rear hinge cover
8	Edge trim, 800mm
1	Driver / left front lower bracket
1	Passenger / right front lower bracket
1	Driver / left rear upper bracket
1	Passenger / right rear upper bracket
1	Driver / left rear lower bracket
1	Passenger / right rear lower bracket
2	Rear bracket upper bushings
2	Rear bracket lower bushings
2	Button head bolt, 6mm x 35mm
8	Button head bolt, 6mm x 25mm
10	Flat washer, 6mm x 18mm x 1.6mm
10	Lock washer, 6mm
1	Allen wrench, 4mm

Tools Required

Trim removal tool	Ratchet
Utility knife	Socket, 10mm
Allen wrench, 4mm (included)	--

Torque Specifications

M6 bolt	7 ft-lbs.
M8 bolt	16 ft-lbs.

Use above torque setting unless otherwise noted

Product Registration and Warranty

ARIES stands behind our products with industry-leading warranties. To get copies of the product warranties, register your purchase or provide feedback, visit: warranty.curtgroup.com/surveys

Product Photo



NOTICE

Visit www.ariesautomotive.com for a full-color copy of this instruction manual, as well as helpful videos, guides and much more!

Before you begin installation, read all instructions thoroughly.

Proper tools will improve the quality of installation and reduce the time required.

Periodic inspection of your product should be performed to ensure all hardware and / or components remain secure.

To help prevent damage to the product or vehicle, refer to the specified torque specifications when securing hardware during the installation process.

Maintenance

Mild automotive detergent may be used to clean the product. Do not use dish detergent, abrasive cleaners, abrasive pads, wire brushes or other similar products that may damage the finish.

Step 1

Start installation at the driver / left front door.
Remove the cover from the back of the fender (Figure 1).

Step 2

Remove the hex bolt attaching the top of the fender below / behind the outer mirror (Figure 2).

Step 3

Select the driver / left front mounting bracket.

Reuse the factory hex bolt to attach the bracket to the threaded hole in the body (Figures 3 & 4).

Step 4

Carefully unwrap the driver/left front hinge cover. Cover the top, bottom, inner and outer edges of the cover with the included edge trim (Figure 5).

Note: apply edge trim to all body and fender contact areas. Cut edge trim to fit. Place cover over hinges and check fit of cover and coverage of edge trim. Line up bracket with hole in cover (Figure 6).

Step 5

Attach top of cover to threaded hole in body with the included longer 6mm x 35mm button head bolt, 6mm lock washer and 6mm flat washer (Figure 7).

Attach the bottom of the cover to the front mounting bracket with 6mm x 25mm button head bolt, 6mm lock washer and 6mm flat washer (Figure 8). Adjust the cover and bracket to fit properly and fully tighten all hardware (Figure 9).

Step 6

Move to the driver / left rear door opening. Select the driver / left upper rear bracket (Figure 10). Remove the 6mm hex nut, lock washer and flat washer from the bottom of the upper hinge.

Step 7

Reuse the 6mm flat washer, lock washer and hex nut to attach the mounting bracket to the bottom of the hinge (Figures 11 & 12).

Step 8

Select the driver / left lower rear bracket, upper bushing and lower bushing (Figure 13). Insert the lower bushing into the bottom of the flat end of the bracket. Push the upper bushing down into the lower bushing.

Step 9

Next, remove the 8mm hex bolt, lock washer and flat washer from the top of the lower hinge (Figure 14). Reuse the 8mm hex bolt, lock washer and flat washer to attach the lower bracket to the top of the lower hinge (Figure 15).

Step 10

Select the driver / left rear hinge cover. Cover the top, bottom and inner edges of the cover with the included edge trim (Figure 16). **Note:** apply edge trim to all body contact areas of cover. Cut edge trim to fit.

Step 11

Attach top of cover to threaded holes in upper bracket with the included 6mm x 25mm button head bolts, 6mm lock washers and 6mm flat washers (Figure 17).

Attach the bottom of the cover to the lower mounting bracket with 6mm x 25mm button head bolt, 6mm lock washer and 6mm flat washer (Figure 18). Adjust the cover and bracket to fit properly against the body and fully tighten all hardware (Figure 19).

Step 12

Repeat Steps 1 - 11 to install the passenger / right hinge cover.

Step 13

Do periodic inspections to the installation to make sure that all hardware is secure and tight.

Driver/left Side Installation Pictured

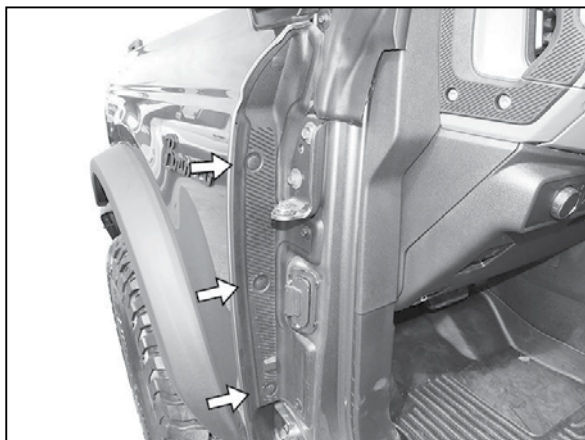

(Fig 1) Remove cover from back of fender (arrows)

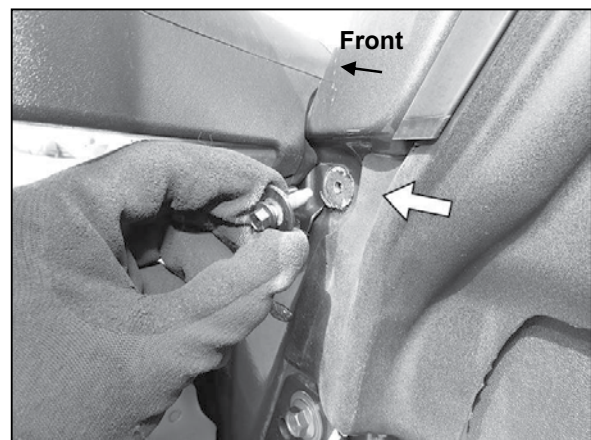

(Fig 2) Remove top fender bolt below/behind outside mirror (arrow)

Driver/left Side Installation Pictured

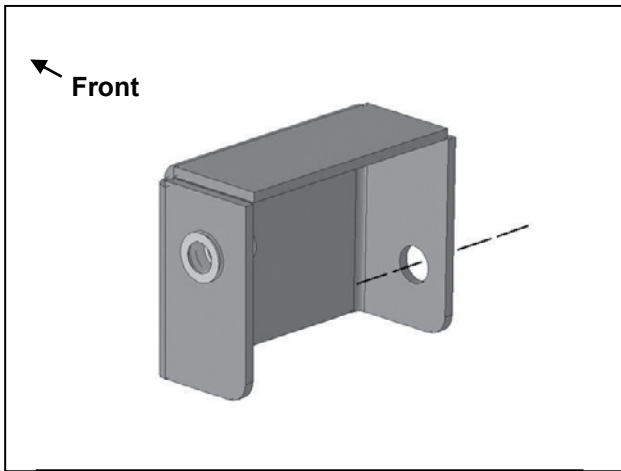

(Fig 3) Driver/left Front Mounting Bracket

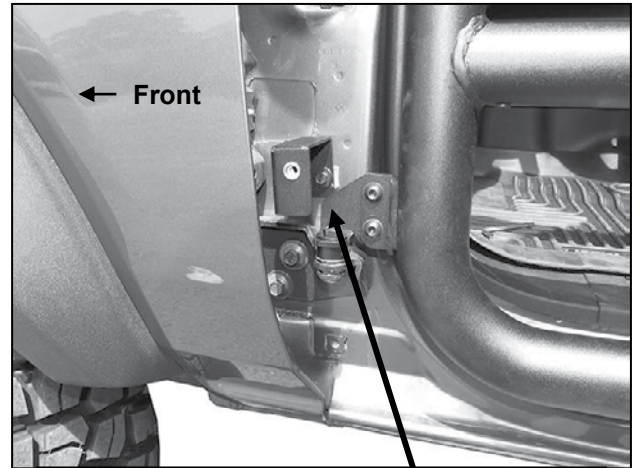

(Fig 4) Reuse the factory hex bolt to attach the driver/left Front Mounting Bracket

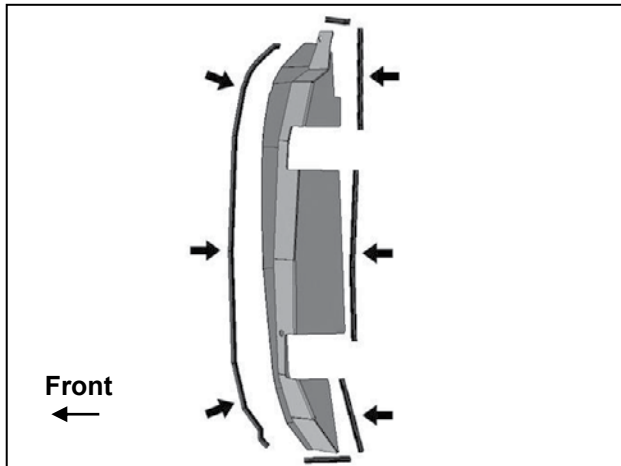

(Fig 5) Attach the included Edge Trim to all contact areas on Hinge Cover. Cut Trim to fit

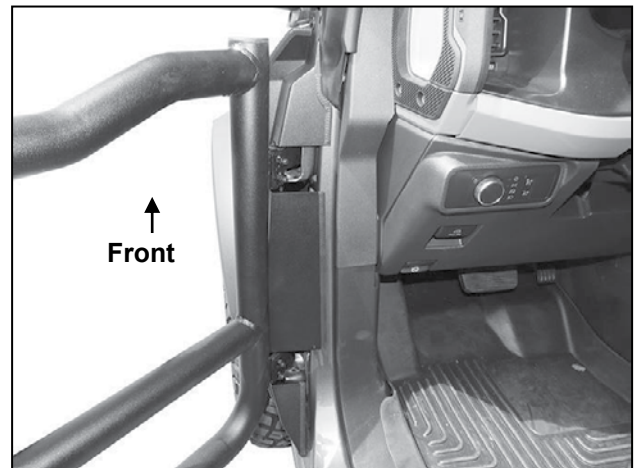

(Fig 6) Check fit of Edge Trim on cover. Line up Mounting Bracket with hole in Cover

Driver/left Side Installation Pictured

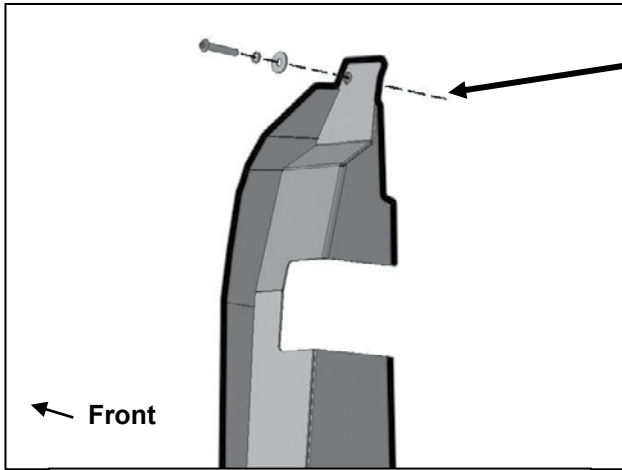

6mm x 35mm Button Head Bolt
6mm Lock Washer
6mm Flat Washer

6mm x 25mm Button Head Bolt
6mm Lock Washer
6mm Flat Washer

(Fig 7) Attach top of Front Cover to body

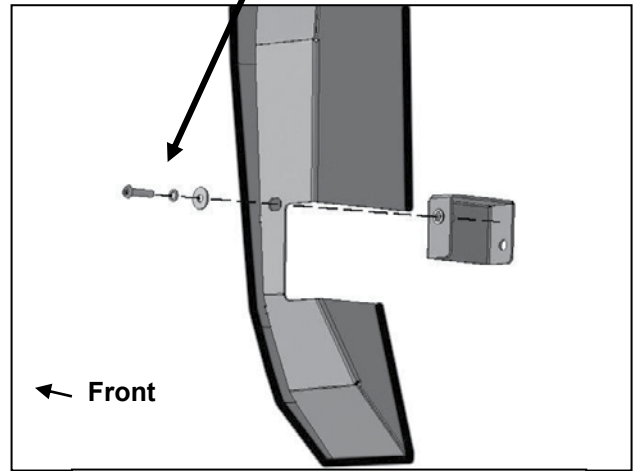

(Fig 8) Attach bottom of driver/left Front Cover to Front Mounting Bracket



(Fig 9) Adjust fit of Cover and fully tighten all hardware

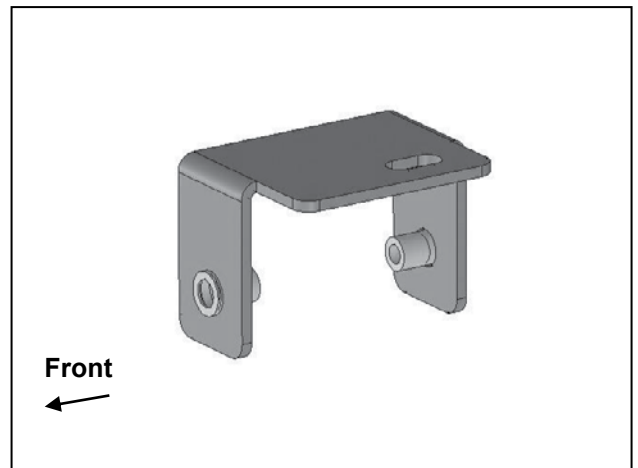

(Fig 10) Driver/left Rear Upper Bracket

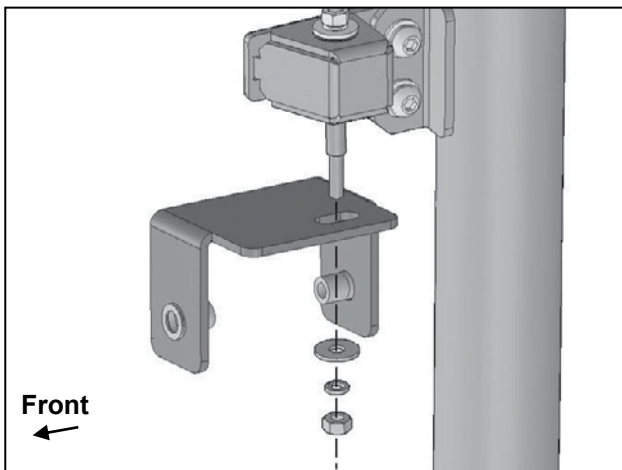

(Fig 11) Reuse the hex nut and washers to attach the Driver/left Rear Upper Bracket to the bottom of the hinge on the body

Driver/left Side Installation Pictured

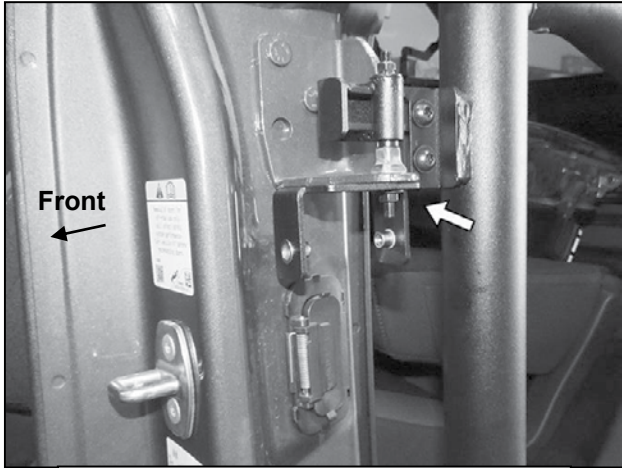

(Fig 12) Driver/left Rear Upper Bracket attached to the bottom of the hinge

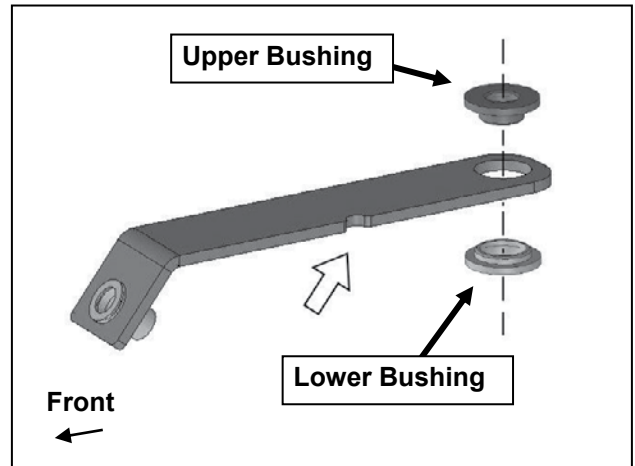

(Fig 13) Insert (1) Lower Bushing into hole in Driver/left Rear Lower Bracket. Push Upper Bushing down into Lower Bushing. NOTE Notch in Bracket for identification purposes

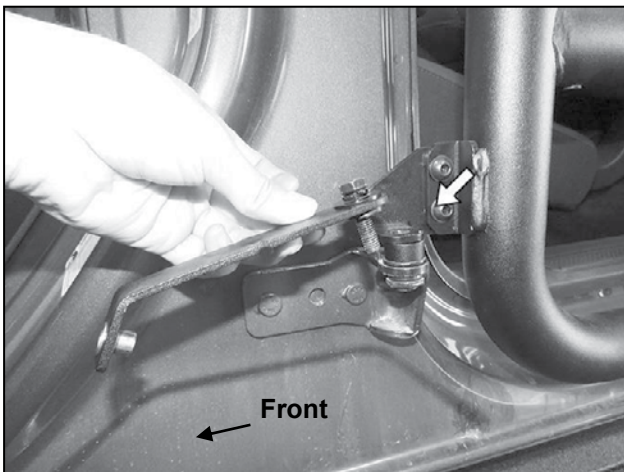

(Fig 14) Reuse the 8mm hex bolt and washers to attach the Driver/left Rear Lower Bracket to the top of the lower hinge

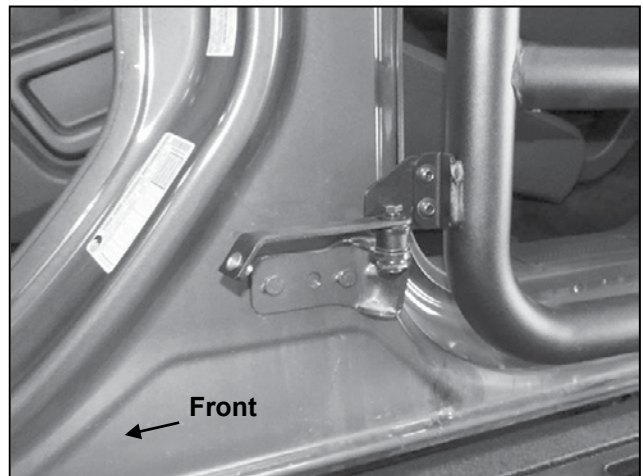

(Fig 15) Driver/left Rear Lower Bracket attached to the top of the lower hinge

Driver/left Side Installation Pictured

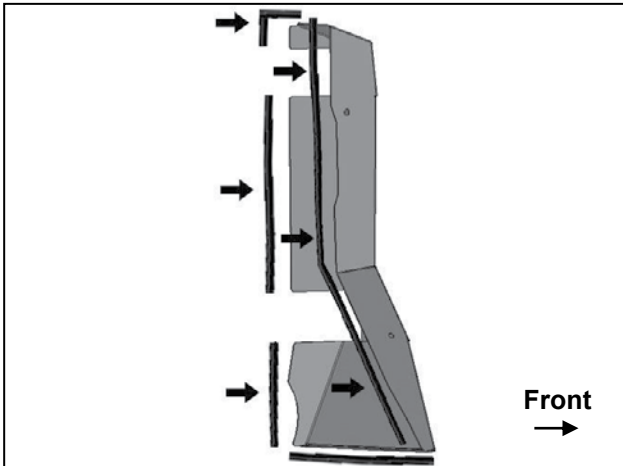

(Fig 16) Attach the included Edge Trim to all contact areas on Hinge Cover. Cut Trim to fit. Check fit of Edge Trim on cover and place cover over hinges. Line up Mounting Brackets with holes in Cover

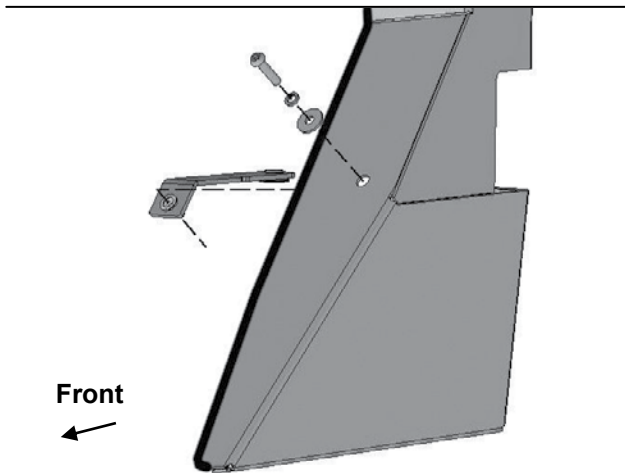

(Fig 18) Attach bottom of driver/left Rear Cover to Lower Mounting Bracket

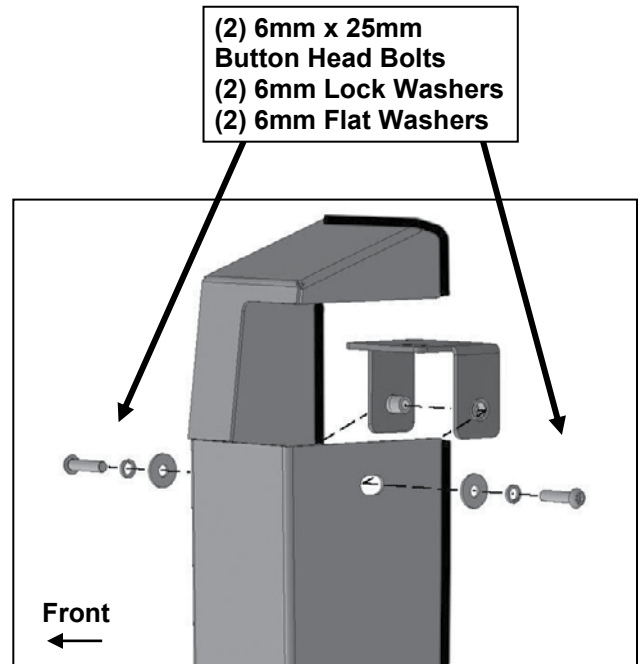

(Fig 17) Attach top of driver/left Rear Cover to Upper Mounting Bracket

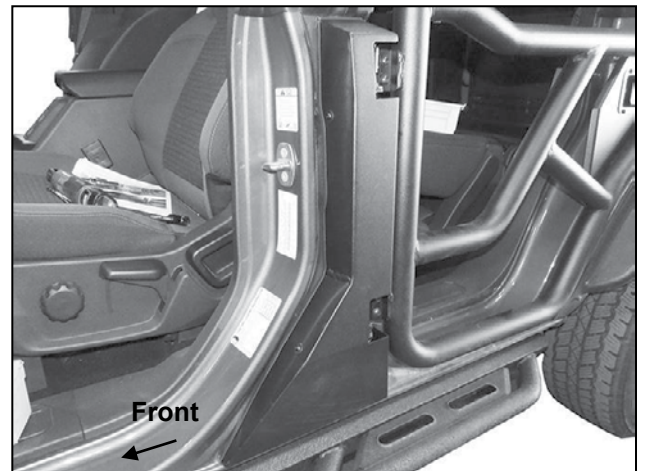

(Fig 19) Adjust fit of Cover and fully tighten all hardware