

Parts List

1	Driver / left, side bar
1	Passenger / right, side bar
1	Mounting bracket, driver / left, front
1	Mounting bracket, passenger / right, front
1	Frame bracket, driver / left, front
1	Frame bracket, passenger / right, front
1	Frame bracket, driver / left, rear
1	Frame bracket, passenger / right, rear
1	Support bracket, driver / left, rear
1	Support bracket, passenger / right, rear
6	Bolt plate, long, welded washer M12 - 1.75 x 40mm
2	Bolt plate, long, M12 - 1.75 x 40mm
2	Bolt plate, short, M12 - 1.75 x 45mm
4	Hex bolt, M12 - 1.75 x 35mm
10	Flat washer, M12 x 24mm x 2.5mm
8	Flat washer, M12 x 32mm x 3mm
14	Lock washer, M12
14	Hex nut, M12
10	Plastic bolt retainer, M12
8	Hex bolt, M8 - 1.25 x 25mm
2	Hex bolt, M10 - 1.50 x 35mm
4	Flat washer, M10 x 20mm x 2mm
8	Flat washer, M8 x 24mm x 2mm
8	Lock washer, M8
2	Lock washer, M10
2	Hex nut, M10

Level of Difficulty

Easy



Scan for helpful install tips

Product Image



Brackets and Hardware

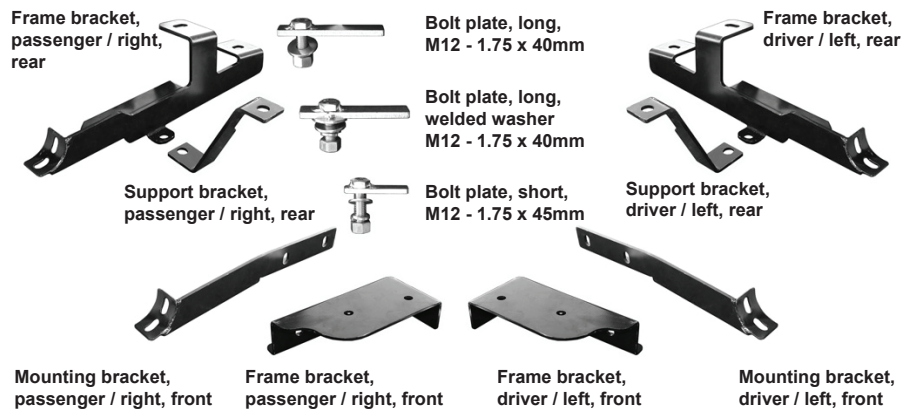

Torque Specifications

	Torque Specifications	
METRIC	M6 bolt	3 ft.-lbs.
	M8 bolt	7 ft.-lbs.
	M10 bolt	16 ft.-lbs.
	M12 bolt	28 ft.-lbs.
SAE	1/4" bolt	3 ft.-lbs.
	5/16" bolt	7 ft.-lbs.
	3/8" bolt	16 ft.-lbs.
	7/16" bolt	20 ft.-lbs.
	1/2" bolt	28 ft.-lbs.

Notes and Maintenance

Before you begin installation, read all instructions thoroughly.

Proper tools will improve the quality of installation and reduce the time required.

To protect the product, wax after installing. Regular waxing is recommended to add a protective layer over the finish. Do not use any type of polish or wax that may contain abrasives that could damage the finish.

For gloss black finishes, mild soap may be used to clean the product.

Refer to the table to the left when securing hardware during the installation process to help prevent damage to the product or vehicle.

PROCEDURE:

- 1. REMOVE CONTENTS FROM BOX. VERIFY ALL PARTS ARE PRESENT. READ INSTRUCTIONS CAREFULLY BEFORE STARTING INSTALLATION.**
- Starting at the driver side-front of the vehicle, locate the two factory holes in the floor panel by the front tires. Insert (1) M12 x 40mm Bolt Plate W/Washer into each of the factory holes.
IMPORTANT! Once you have inserted the bolt plates, make sure that the welded washer on each bolt plate is in the center of the factory hole. Slide a plastic bolt retainer over the thread of the bolt to hold the bolt in place. **(Fig's 1A & 1B)**
- Select the driver side front Frame Bracket and hang it from the (2) previously installed Bolt Plates using the included (2) 12mm x 30mm x 3mm Large Flat Washers, (2) M12 Lock Washers and (2) M12 Hex Nuts. Snug but do not tighten hardware at this time, **(Fig 2)**. **NOTE: When tightening the Bolt Plates, make sure that the welded-on washers are fully seated in the large openings in the floor at all times.**
- Bolt the driver side Mounting Bracket to the front Frame Bracket using the included (2) M12 x 35mm Hex Bolts, (4) 12mm 25mm x 2.5mm Flat Washers, (2) M12 Lock Washers and (2) M12 Hex Nuts, **(Fig 3)**. Snug but do not tighten hardware at this time.
- Move to the driver side rear of the vehicle and locate the factory hole (1) in the bottom of the suspension mount and the hole (1) in the bottom of the inner frame channel, **(Fig 4A)**. Select (1) M12 x 40mm Bolt Plate W/Washer and insert it into the large hole in the suspension mount. Select (1) M12 x 40mm Long Bolt Plate, (no washer) and insert it into the hole in the bottom of the frame channel. Slide a plastic bolt retainer over the thread of the bolt to hold the bolt in place. **(Fig's 4A & 4B)** Hang the driver side Rear Mounting Bracket from the (2) Bolt Plates with (2) 12mm x 30mm Large Flat Washers, (2) M12 Lock Washers and (2) 12mm Hex Nuts, **(Fig 5)**. Snug but do not tighten hardware at this time.
- Next, insert (1) M12 x 45mm Small Bolt Plate into the hole in the bottom of the rocker panel. Slide a plastic bolt retainer over the thread of the bolt to hold the bolt in place. **(Fig' 6A & 6B)** Select the driver side Rear Support Bracket. Hang the Support Bracket from the Small Bolt Plate with (1) 12mm x 25mm Flat Washer, (1) M12 Lock Washer and (1) M12 Hex Nut, **(Fig 7)**. Line up the lower hole in the Support Bracket with the bottom of the tab on the rear Mounting Bracket. Bolt the Support Bracket to the Mounting Bracket with (1) M10 x 35mm Hex Bolt, (2) 10mm Flat Washers, (1) 10mm Lock Washer and (1) M10 Hex Nut, **(Fig 7)**. Snug all hardware but go not fully tighten at this time.
- Carefully position the driver Sidebar onto the Mounting Brackets and attach it using the included (4) M10 x 30mm Hex Bolts, (4) M10 Lock Washers and (4) 10mm Flat Washers, **(Fig 8)**. Do not tighten hardware at this time.
- Align and adjust the Sidebar properly and fully tighten all hardware. **IMPORTANT: Before tightening the front Support Bracket and the rear Mounting Bracket to vehicle, make sure that Bolt Plates are in the center of the holes in the vehicle.**
- Repeat steps 2 – 8 for passenger Sidebar installation.
- Do periodic inspections to the installation to make sure that all hardware is secure and tight.

Driver Side Installation Pictured

